

PAPER • OPEN ACCESS

SVM Based Reduction of Input Current Harmonics in Three Phase Rectifier

To cite this article: T. Kesavan *et al* 2020 *IOP Conf. Ser.: Mater. Sci. Eng.* **937** 012058

View the [article online](#) for updates and enhancements.



ECS **240th ECS Meeting**
Oct 10-14, 2021, Orlando, Florida

**Register early and save
up to 20% on registration costs**

Early registration deadline Sep 13

REGISTER NOW

SVM Based Reduction of Input Current Harmonics in Three Phase Rectifier

T.Kesavan¹, S. Sheebarani Gnanamalar², S.Sivaranjani³, V.Gomathy⁴,
G.Radhakrishnan⁵ and R. Sitharthan⁶

^{2,4,5} Prof, Department of Electrical and Electronics Engineering,

^{1,3} Asst.Professor, Department of Electrical and Electronics Engineering,
Sri Krishna College of Engineering and Technology

Coimbatore, Tamilnadu, India

⁶School of Electrical Engineering, Vellore Institute of Technology, Vellore.

Email: ¹t.kesavan87@gmail.com, ²sheebaranis@skcet.ac.in, ³sivaranjanis@skcet.ac.in,
⁴gomathyv@skcet.ac.in and ⁵radhakrishnang@skcet.ac.in

Abstract. Current Scenario of power system engineering field is facing problem of harmonics in voltage and current. In power converter harmonics are mainly disturb the stability of voltage and current in uncertainty of load and transient. This paper proposes space vector modulation based analysis of input current in 3 phase converter. Harmonics in input current in converter is a big challenge of power Electronics research. In power converters non-linear load are one of the reason for increasing the harmonics in electronic circuits. Modified space vector modulation is proposed for reducing the harmonics in 3 phase converter and also control the total harmonic distortion. Matlab simulink software is used to simulate and analyse the 3 phase converter and SVM is modelled for above converter. In this propose method THD of input current harmonics has reduced below 5 percentages and compared with IEEE standard.

Keywords:-- Harmonic current, Harmonic distortion, PWM, SVM.

1. Introduction

Increasing a stage of non linear load in our electrical field harmonics are placed in would it an current. Harmonics are defenders the multiple integral of fundamental frequency In linear load the voltage and current are linearly very good that means both are directly proportional to the each other. Example of linear load is a direct current serious and front motors. In non linear load the voltage and current are inversely proportional and not buried linearly. Induction motor and synchronous motor and special electrical machines are examples of non linear load. in non linearity electrical circuits having problems in frequency. A power Electronics converter operation depends on switching variations of power electronic devices. Due to transient of electronic circuits .harmonious may be developed changes or load variation of circuit as developing the harmonics.

In advance the life the world is started to run essay automatic smart and digital. Games and controllers are parts of automatic welding. Man linear load or necessarily for real time automatic condition power electronic converter for controlled need to control the non linear load especially for Electrical drives. Generally conventional electrical motors may be used in open loop system without automatic. Non-



conventional Motors power electronic commentator are converted with electrical Motors search with the exact speed control. Harmonics are developing the converter circuit due to the speed variation in power electronics circuits. As per IEEE standard total harmonic distortion of voltage should be less than 5 percentages and current less than 10 percentages but real time due to usage non linear loads and also based on induction principle motors, it produces maximum harmonics in voltage and current. Some of major harmonics producers from AC drives in induction motor, synchronous motor, Blde motor, switched reluctance motor and PMSM motor.

Figure 1 shows the proposed concept block diagram of three phase inverter with SVM technique. In this concept output current are taken as feedback from 3 phase converter and is compared with reference current. Error can be detected and it is converted into two current regulators, the duty of current regulator is producer architecture access current and direct Axis current. In this time direct answer is current or considered as zero. Proportional integral controllers are used as current regulator for developing the current I_{qs} based on the error from detector. In generally proportional controller may be used to get quick settling time of a signal and integral controller are prescribed for reducing peak overshoot of the signal. Voltage regulator develops the voltage of quadrature Axis and direct axis depend upon the harmonic calculation. Three phase voltages of ABC are converted into v_{ds} and v_{qs} by DQ transformation. Based the basic concept of SPM produces the gate pulses for three phase converter. In this type getting calls itself hormones can reduces to converter. Three phase rectifier can operating by giving firing pulse from space vector modulation. Finally three phase converter competitions the output voltage with fewer amounts of harmonics and total harmonic distortion of current can be read easily below 5 percentages with attribute standard.

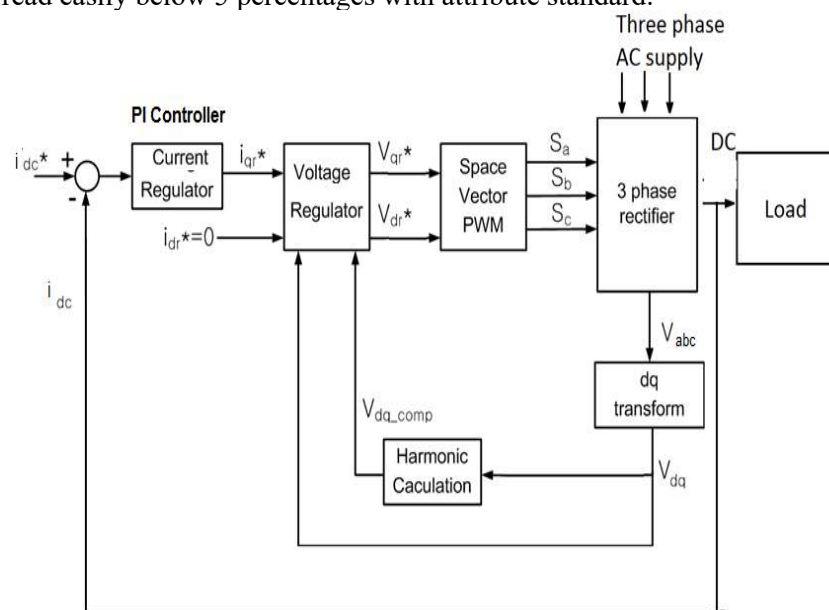

Figure 1. Block diagram of the Proposed PWM rectifier

2. Space Vector Pulse Width Modulation

Space Vector Modulation was developed in the year of 1980s. In conventional pulse width modulation techniques, reference signals compare with carrier signals modulation pwm signals can produced. Some of conventional methods are sinusoidal pulse width modulation multiple pwm, single pwm, trapezoidal pwm and harmonic pwm. In SVM consist of eight vector for states during the time period of TS and eighth factor are called as zero state or null vector because there is no power old flowing from source to load during the zero state operation so in which state all the switches or off condition. In other states in anyone switch will be turn on so the voltage are flowing from input to load the switching States from 2 to 7 are operating States. Figure 2 shows the switching state of proposal space

vector modulation. The total time period of modulation technique is 360 degree and each modulation consists of minimum 30degree. For power converter each States consists of vectors and switches are controlled by by svm get pulses. Output voltage can be improved in this method and harmonics are maximum reduced [13].

$$V_k = \frac{2}{3} V_{dc} * e^{j(k-1)\frac{\pi}{3}}, k=1,2,\dots,6. \quad (1)$$

$$T_1 = M * \frac{\sin(60^\circ - \alpha)}{\sin 60^\circ} * T_s \quad (2.1)$$

$$T_2 = M * \frac{\sin \alpha}{\sin 60^\circ} * T_s \quad (2.2)$$

$$T_Z = T_s - T_1 - T_2 \quad (2.3)$$

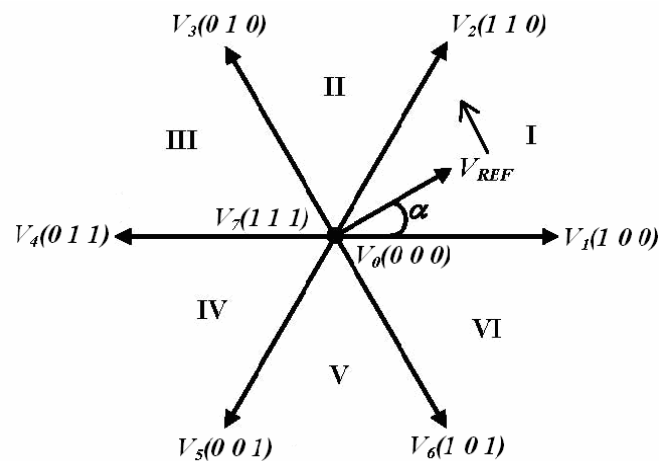

Figure 2. Switching states and corresponding voltage vectors of a three phase VSI. I, II, III, IV, V, VI are the sectors.

Thus, SVPWM uses $V_0, V_k, V_{k+1}, V_7, V_{k+1}, V_k, V_0$ sequence for odd sectors and $V_0, V_{k+1}, V_k, V_7, V_k, V_{k+1}, V_0$ sequence for even sectors respectively.

3. Harmonics Reduction Technique of Input Currents

Stationary frame of current can be converted into synchronous form is shown in equation 3.

$$\begin{bmatrix} i_d^{s*} \\ i_q^{s*} \end{bmatrix} = \begin{bmatrix} \cos \theta & -\sin \theta \\ \sin \theta & \cos \theta \end{bmatrix} \begin{bmatrix} i_d^{e*} \\ i_q^{e*} \end{bmatrix}. \quad (3)$$

$$\begin{aligned} \begin{bmatrix} i_d^{s*} \\ i_q^{s*} \end{bmatrix} &= \begin{bmatrix} \cos(\theta + \Delta\theta) & -\sin(\theta + \Delta\theta) \\ \sin(\theta + \Delta\theta) & \cos(\theta + \Delta\theta) \end{bmatrix} \begin{bmatrix} i_d^{e**} \\ i_q^{e**} \end{bmatrix} \\ &= \begin{bmatrix} \cos \theta & -\sin \theta \\ \sin \theta & \cos \theta \end{bmatrix} \begin{bmatrix} i_d^{e*} \\ i_q^{e*} \end{bmatrix}. \end{aligned} \quad (4)$$

By using the references i^{c**}_d , i^{c**}_q and the phase angle, the corrected current references i^{e**}_d , i^{e**}_q can be derived by (6).

$$\begin{aligned} \begin{bmatrix} i^{e**}_d \\ i^{e**}_q \end{bmatrix} &= \begin{bmatrix} \cos(\theta + \Delta\theta) & -\sin(\theta + \Delta\theta) \\ \sin(\theta + \Delta\theta) & \cos(\theta + \Delta\theta) \end{bmatrix}^{-1} \begin{bmatrix} i^{s**}_d \\ i^{s**}_q \end{bmatrix} \\ &= \begin{bmatrix} \cos(\theta + \Delta\theta) & \sin(\theta + \Delta\theta) \\ -\sin(\theta + \Delta\theta) & \cos(\theta + \Delta\theta) \end{bmatrix} \begin{bmatrix} i^{s**}_d \\ i^{s**}_q \end{bmatrix} \\ &= \begin{bmatrix} \cos(\theta + \Delta\theta) & \sin(\theta + \Delta\theta) \\ -\sin(\theta + \Delta\theta) & \cos(\theta + \Delta\theta) \end{bmatrix} \begin{bmatrix} \cos\theta & -\sin\theta \\ \sin\theta & \cos\theta \end{bmatrix} \begin{bmatrix} i^{e*}_d \\ i^{e*}_q \end{bmatrix} \\ &= \begin{bmatrix} \cos\Delta\theta & \sin\Delta\theta \\ -\sin\Delta\theta & \cos\Delta\theta \end{bmatrix} \begin{bmatrix} i^{e*}_d \\ i^{e*}_q \end{bmatrix}. \end{aligned} \tag{5}$$

$$\begin{aligned} [R(\theta)] \begin{bmatrix} \cos(\theta + \Delta\theta) \\ \sin(\theta + \Delta\theta) \end{bmatrix} &= \begin{bmatrix} \cos\theta & \sin\theta \\ -\sin\theta & \cos\theta \end{bmatrix} \begin{bmatrix} \cos(\theta + \Delta\theta) \\ \sin(\theta + \Delta\theta) \end{bmatrix} \\ &= \begin{bmatrix} \cos\theta \cos(\theta + \Delta\theta) + \sin\theta \sin(\theta + \Delta\theta) \\ -\sin\theta \cos(\theta + \Delta\theta) + \cos\theta \sin(\theta + \Delta\theta) \end{bmatrix} \\ &= \begin{bmatrix} \cos\Delta\theta \\ \sin\Delta\theta \end{bmatrix}. \end{aligned} \tag{6}$$

The distortion components $\sin\Delta\theta$ and $\cos\Delta\theta$ necessary for calculating (4) can be obtained by (5). To extract such distortion components, the phase angles θ and $\theta + \Delta\theta$ should be known

4. Simulations and Results

Figure.3 Shows MATLAB simulation of Three phase Rectifier under the distortion of Input Voltage. Here Source voltage is distorted by series connected reactance. MATLAB /Simulink diagram has been run up to 0.1 sec and fundamental frequency of supply is 50 Hz.

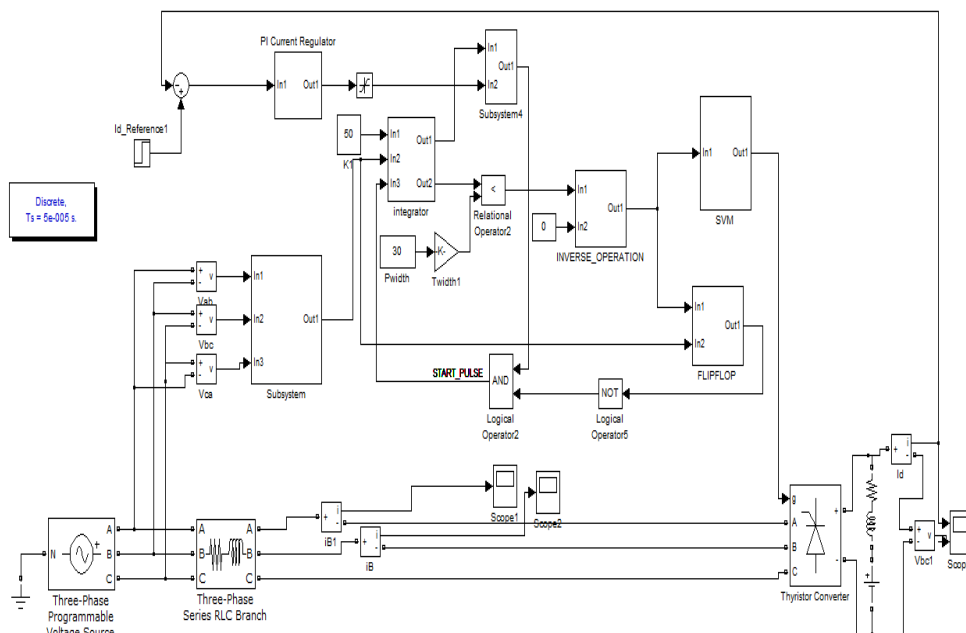

Figure 3. MATLAB Simulation of SVM based Three Phase Rectifier

Figure 4 shows Actual output current and reference current of three phase Rectifier. Reference current is settled 10A at t=0sec and current is changed to 25A at t=0.06sec as shown in Figure

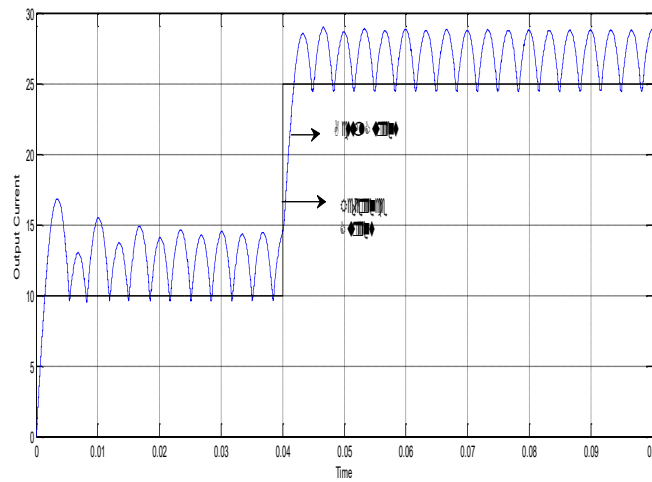

Figure 4.Actual Output current and reference current of three phase Rectifier.

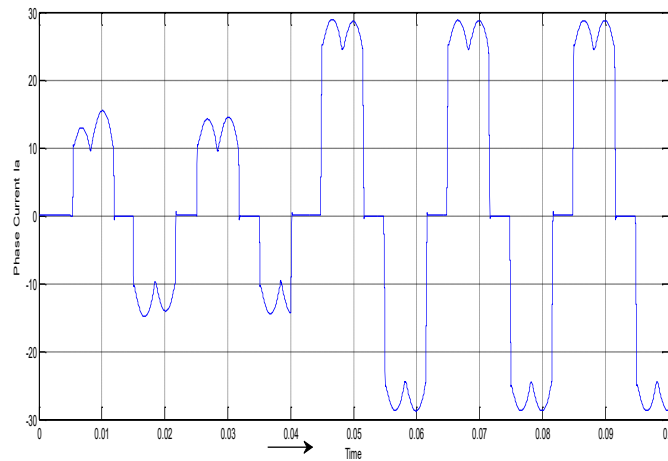

Figure 5.Input Phase Current Ia of Three phase Rectifier

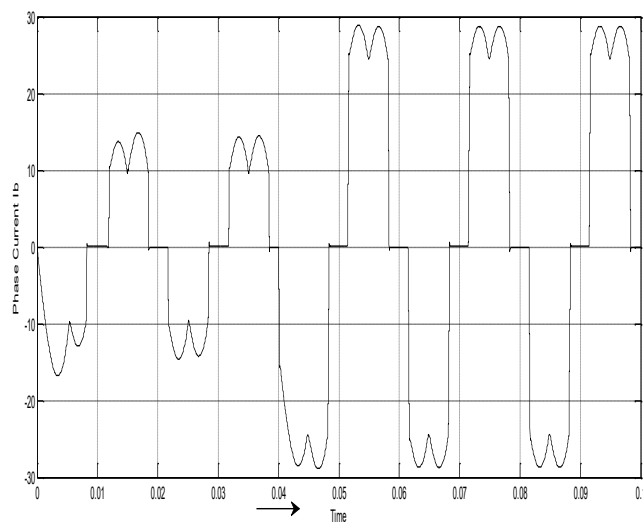

Figure 6.Input Phase Current Ib of Three phase Rectifier

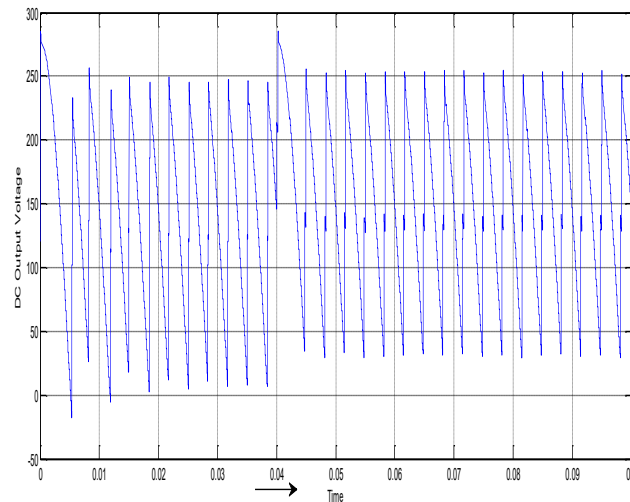

Figure 7. Output DC Voltage of Three phase Rectifier

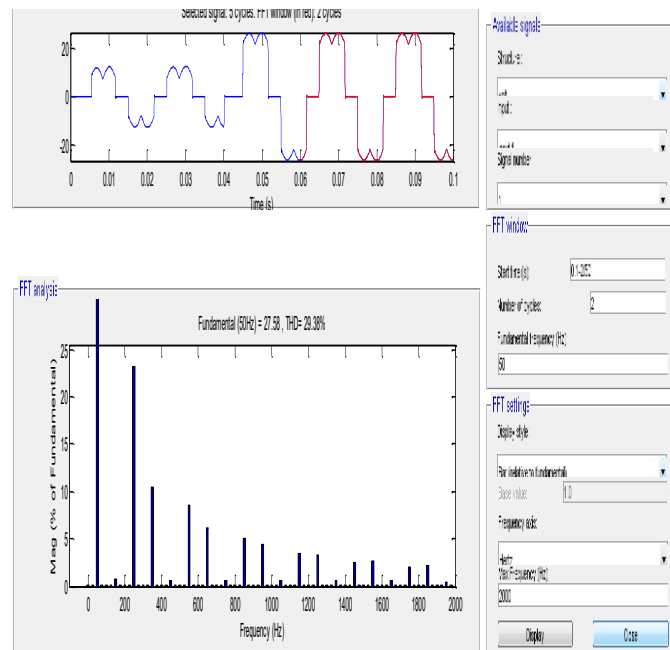

Figure 8. THD Analysis of Input Phase Current Ia of Three phase Rectifier

Figure 8 shows the THD Analysis of Input Phase Current Ia of Three phase Rectifier. By using proposed method, getting the THD 2.23% of Input phase current.

5. Conclusion

In this paper input phase current harmonics of three phase rectifier has been analysed by MATLAB simulation. THD of input current under source voltage distorted has been minimized without using any additional filter circuit. Output current of rectifier has been controlled by space vector Modulation should have a brief caption describing it and, if necessary, a key to interpret the various lines and symbols on the figure.

References

- [1]. Jerin ARA, Kaliannan P and Subramaniam U 2017 Improved fault ride through capability of DFIG based wind turbines using synchronous reference frame control based dynamic voltage restorer. *ISA transactions* **70** 465-474
- [2]. Sitharthan, R, Sundarabalan CK, Devabalaji KR, Nataraj SK and Karthikeyan M 2018 Improved fault ride through capability of DFIG-wind turbines using customized dynamic voltage restorer *Sustainable cities and society* **39** 114-125
- [3]. Prabakaran N and Palanisamy K 2016 A single-phase grid connected hybrid multilevel inverter for interfacing photo-voltaic system *Energy Procedia* **103** 250-255
- [4]. Palanisamy K, Mishra JS, Raglend IJ and Kothari DP 2010 Instantaneous power theory based unified power quality conditioner (UPQC) *IEEE Joint International Conference on Power Electronics, Drives and Energy Systems* 1-5
- [5]. Sitharthan R and Geethanjali M 2017 An adaptive Elman neural network with C-PSO learning algorithm-based pitch angle controller for DFIG based WECS *Journal of Vibration and Control* **23(5)** 716-730
- [6]. Sitharthan R and Geethanjali M 2015 Application of the superconducting fault current limiter strategy to improve the fault ride-through capability of a doubly-fed induction generator-based wind energy conversion system *Simulation* **91(12)** 1081-1087
- [7]. Sitharthan R, Karthikeyan M, Sundar DS and Rajasekaran S 2020 Adaptive hybrid intelligent MPPT controller to approximate effectual wind speed and optimal rotor speed of variable speed wind turbine *ISA transactions* **96** 479-489
- [8]. Sitharthan R, Devabalaji KR and Jeas A 2017 An Levenberg–Marquardt trained feed-forward back-propagation based intelligent pitch angle controller for wind generation system *Renewable Energy Focus* **22** 24-32
- [9]. Sitharthan R, Sundarabalan CK, Devabalaji KR, Yuvaraj T and Mohamed Imran A 2019 Automated power management strategy for wind power generation system using pitch angle controller *Measurement and Control* **52(3-4)** 169-182
- [10]. Sundar DS, Umamaheswari C, Sridarshini T, Karthikeyan M, Sitharthan R, Raja AS and Carrasco MF 2019 Compact four-port circulator based on 2D photonic crystals with a 90° rotation of the light wave for photonic integrated circuits applications *Laser Physics* **29(6)** 066201
- [11]. Sitharthan R, Parthasarathy T, Sheeba Rani S and Ramya KC 2019. An improved radial basis function neural network control strategy-based maximum power point tracking controller for wind power generation system *Transactions of the Institute of Measurement and Control* **41(11)** 3158-3170
- [12]. Rajesh M and Gnanasekar JM 2017 Path observation based physical routing protocol for wireless ad hoc networks *Wireless Personal Communications* **97(1)** 1267-1289
- [13]. Palanisamy K, Varghese LJ, Raglend IJ and Kothari DP 2009. Comparison of intelligent techniques to solve economic load dispatch problem with line flow constraints *IEEE International Advance Computing Conference* 446-452
- [14]. Sitharthan R, Ponnusamy M, Karthikeyan M and Sundar DS 2019 Analysis on smart material suitable for autogenous microelectronic application *Materials Research Express* **6(10)** 105709
- [15]. Rajaram R, Palanisamy K, Ramasamy S and Ramanathan P 2014 Selective harmonic elimination in PWM inverter using fire fly and fireworks algorithm *International Journal of Innovative Research in Advanced Engineering* **1(8)** 55-62
- [16]. Sitharthan R, Swaminathan JN and Parthasarathy T 2018 March. Exploration of wind energy in India: A short review *IEEE National Power Engineering Conference* 1-5

- [17]. Karthikeyan M, Sitharthan R, Ali T and Roy B 2020 Compact multiband CPW fed monopole antenna with square ring and T-shaped strips *Microwave and Optical Technology Letters* **62(2)** 926-932
- [18]. Sundar D Sridarshini T, Sitharthan R, Madurakavi Karthikeyan, Sivanantha Raja A, and Marcos Flores Carrasco 2019 Performance investigation of 16/32-channel DWDM PON and long-reach PON systems using an ASE noise source *In Advances in Optoelectronic Technology and Industry Development: Proceedings of the 12th International Symposium on Photonics and Optoelectronics* 93
- [19]. Sitharthan R and Geethanjali M 2014 Wind Energy Utilization in India: A Review *Middle-East J. Sci. Res.* **22** 796–801 doi:10.5829/idosi.mejsr.2014.22.06.21944
- [20]. Sitharthan R and Geethanjali M 2014 ANFIS based wind speed sensor-less MPPT controller for variable speed wind energy conversion systems *Australian Journal of Basic and Applied Sciences* **8**14-23