



12th GLOBAL CONGRESS ON MANUFACTURING AND MANAGEMENT, GCMM 2014

A PRELIMINARY ASSESSMENT OF MACHINABILITY OF TITANIUM ALLOY Ti 6Al 4V DURING THIN WALL MACHINING USING TROCHOIDAL MILLING

Ashwin Polishetty^{a*}, Moshe Goldberg^b, Guy Littlefair^c, Mahesh Puttaraju^d, Prasad Patil^e,
Akshay Kalra^f

^{a,b,c,d,e}Deakin University, School of Engineering, 75 Pigdons Road, Waurn Ponds, VIC 3216, Australia
^fVIT University, School of mechanical and Building Sciences, Vellore-632403, Tamil Nadu, India

Abstract

Titanium alloys are of great demand in the aerospace and biomedical industries. Most the titanium products are either cast or sintered to required shape and finish machined to get the appropriate surface texture to meet the design requirements. Ti-6Al-4V is often referred as work horse among the titanium alloys due to its heavy use in the aerospace industry. This paper is an attempt to investigate and improve the machining performance of Ti-6Al-4V. Thin wall machining is an advance machining technique especially used in machining turbine blades which can be done both in a conventional way and using a special technique known as trochoidal milling. The experimental design consists of conducting trials using combination of cutting parameters such as cutting speed (vc), 90 and 120 m/min; feed/tooth (fz) of 0.25 and 0.35 mm/min; step over (ae) 0.3 and 0.2; at constant depth of cut (ap) 20mm and using coolant. A preliminary assessment of machinability of Ti-6Al-4V during thin wall machining using trochoidal milling is done. A correlation established using cutting force, surface texture and dimensional accuracy.

© 2014 The Authors. Published by Elsevier Ltd. This is an open access article under the CC BY-NC-ND license (<http://creativecommons.org/licenses/by-nc-nd/3.0/>).

Selection and peer-review under responsibility of the Organizing Committee of GCMM 2014

Keywords: Titanium Alloy Ti6Al-4V; Machinability; Trochoidal Milling

* Corresponding author : Ashwin Polishetty
E-mail address: ashwin.polishetty@deakin.edu.au

1. Introduction

Titanium has unique properties such as high strength to weight ratio, good resistance to corrosive environments. It can be used over a wide range of applications due to its superior material properties. The relatively high melting point makes it useful as refractory material. Several superior properties, such as exceptional thermal resistance, high load bearing capacity and ability to resist corrosion, of these materials categorize them as super-alloy.

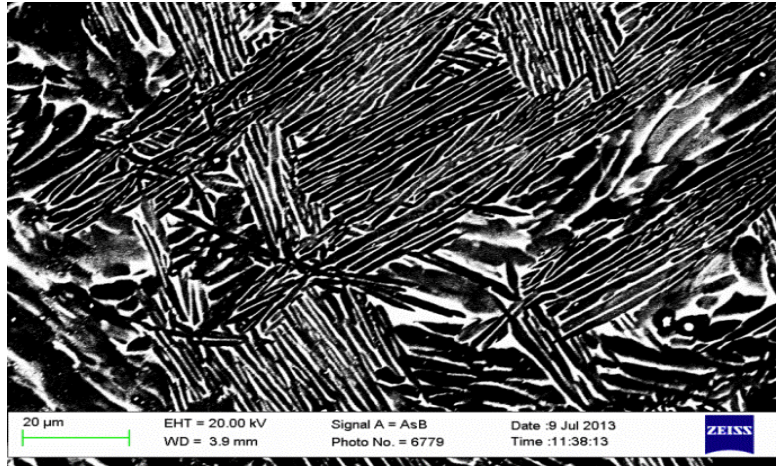

Fig. 1 Ti-6Al-4V microstructure – before machining

Typical engineering applications of titanium alloys include the manufacture of cryogenic devices and aerospace components [1]. Titanium has low thermal conductivity; hence the heat generated by the cutting action does not dissipate quickly [2, 3]. Another property is strong alloying tendency or chemical reactivity with the most tool materials which causes rapid wear of the cutting tool [2, 3]. Titanium exists in two crystallographic forms. At room temperature unalloyed titanium has a Hexagonal Close-Packed structure (HCP) crystal structure known as alpha phase. At 883°C this transforms to a Body Centered Cubic (BCC) known as beta phase [1]. The microstructure of Ti-6Al-4V before machining is shown in figure 1. Titanium has unique properties such as high strength to weight ratio, good resistance to corrosive environments. It can be used over a wide range of applications due to its superior material properties. The relatively high melting point makes it useful as refractory material. Several superior properties, such as exceptional thermal resistance, high load bearing capacity and ability to resist corrosion, of these materials categorize them as super-alloy. The most noted chemical property of titanium is excellent resistance to corrosion. The melting of titanium is only possible in an inert atmosphere or vacuum [4]. When machining any component it is essential to satisfy surface integrity requirements. However during machining and grinding operations, the surface of titanium alloys is easily damaged due to their poor machinability [5]. The temperature gradient during cooling the huge casting of stock material generates residual stress which later distorts the machined part [6, 7]. Aerospace components are generally made by removing huge amount of scarf from big blocks of material. Near net shaping method is very difficult for most of the aerospace components due to complex physical shape, and high tolerance and good surface finish requirements [8]. The Boeing 747 beam is one of the largest titanium forgings produced. The preferable material for this application would have been an aluminium alloy, such as 7075, as the cost would be much lower. However, to carry the required loads, the machined aluminium component would not fit within the envelope of the wing. Steel could have been used, but it would have been heavier owing to the higher density [9]. Cobalt-bound tungsten carbide cutting tools are widely accepted as the best tooling for machining Ti-6Al-4V. The higher strength of Ti-6Al-4V would permit reducing the wall thickness, enhancing the weight savings [9]. Vanadium (V) is added to pure Ti to reduce the β transition temperature for stabilizing the β phase and

aluminium (Al) is added to increase the β transition temperature. Ti–6Al–4V consists of 6 wt% of Al and 4 wt% V. The β transition temperature of this composition is 995 °C, beyond this temperature it is 100% β phase [7].

2. Trochoidal machining

Trochoidal milling is a circular milling which includes simultaneous forward movements the cutter removes repeated slices of material in a sequence of continuous spiral tool paths in its radial direction[10].The tool is programmed with a roll entry into and exit from cut. The radial pitch (w) as shown in the fig 2 kept low as possible to improve surface finish.

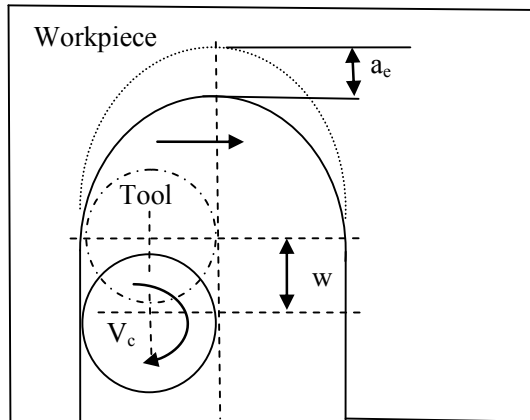

Fig 2. Trochoidal milling diagram

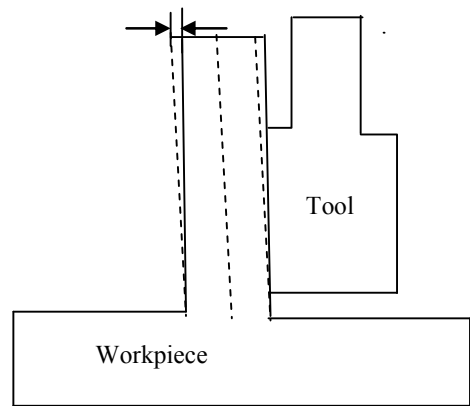

Fig 3. Deformation (δ) in thin-wall machining

The advantages of trochoidal milling are:

- Controlled arc of engagement generates low cutting forces which enable high axial depths of cut.
- The whole cutting edge length is utilized ensuring that the heat and wear are uniform and spread out leading to longer tool life than traditional slot milling.
- Due to the start arc of engagements multi edge tools are used which enable high table feed improving tool life.

3. Thin Wall Machining

In general, thin wall machining is defined as the machining of thin walls using a specific height to depth ratio (approx. 15:1) and wall thickness (approx. 3-5 mm) [10]. For this project, the definition of thin wall component is based on dimensional accuracy and wall deflection. To be specific, a thin wall component is where elastic deformation of the wall is larger than or equal to the allowed tolerance requirement and can be written as; $\delta \geq T$, Where δ = elastic deformation of the wall and T = allowed machining tolerance [11]. Thin wall machining aggressively collapses part cycle time by creating one piece flow of monolithic parts. Using this advanced process, there is no need of expensive, time consuming, multiple part manufacturing including laborious setup on different machines and the riveting of pieces together into a finished part [12]. Thin wall machining techniques also provide extensive improvements in part accuracy and quality. The dramatic difference in consistency between a riveted part and a machined part cannot be argued. In fact, thin wall machining techniques can machine Boeing 777 deflection control ribs within "jig bore" tolerance from one part to the next. This accuracy makes it possible to more efficiently machine parts with straight, thin and flat walls to exacting demanding tolerances even at high rpm. In fact, one machining center can now create the same amount of parts that previously needed three or four machines. Efficiencies realized through thin wall machining impact the entire part manufacturing process [12]. On a larger scale, these shortened cycle times provide the flexibility to support JIT manufacturing. Machining ADI using conventional techniques is often problematic due to the microstructural phase change from austenite to martensite [4]. The hypothesis associated with this work is to determine the role of plastic strain (ϵ_p) and thermal energy (Q) in

martensite formation caused by phase transformation during machining. Supportive analysis such as XRD analysis is used to identify and quantify the microstructural phases. The approach connects: theory behind microstructural phase (martensite) evolution, plastic deformation during tensile testing and machining, in order to develop a prediction model for determining the amount of phase transformation (increase in weight fraction of martensite) for a range of plastic deformation. In the past, a lengthy lead time was on a larger scale, these shortened cycle times provide the flexibility to support JIT manufacturing. Because of the poor stiffness of thin-wall feature, deformation is more likely to occur in the machining of thin-wall part which resulting a dimensional surface errors[11]. Figure 3 shows the deformation produced in machining thin-wall feature.

4. Experimental Design

The experimental design consists of two parts; material characterization and the machining trials. Material characterization includes spectrometry analysis, tensile test, bulk hardness test and material characterization of Ti-6Al-4V. Post machining processes include cutting, surface roughness test and dimensional accuracy test of the machined part. The various elements present and the chemical compositions of the Ti-6Al-4V (in wt %) examined by spectroscopic analysis are given in the Table 1. Measured mechanical properties such as bulk hardness, tensile strength of the Ti-6Al-4V alloy are shown in Table 2. The workpiece material used in all the experiment of machining was a bar of dimension 150mm X 50mm X 70mm alpha- beta titanium Ti-6Al-4V alloy. The titanium block was machined with different combinations of milling parameter and the resulting cutting forces were measured using Kistler dynamometer 9257 as shown in Fig.4. The experimental design consists of conducting trials using combination of cutting parameters such as cutting speed (v_c), 90 and 120 m/min; feed/tooth (f_z) of 0.25 and 0.35 mm/min; step over (a_e) 0.3 and 0.2; at constant depth of cut (a_p) 20mm and using coolant. This results in thin wall machining of wall thickness 5mm. The combinational of machining trials using the variations in Speed, Feed and Step Over is given in Table 3. Milling was carried out in a universal line 5-axis CNC machine manufactured by Spinner (Model: U-620). The tool used for milling was coated solid carbide end mill of 12mm diameter containing four teeth, manufactured product of ISCAR-IC900. The coolant used was a phenol-2.8% which is mixed with water in ratio of 1:10. The machinability of titanium during thin wall machining using trochoidal milling was assessed with respect to the cutting force, dimensional accuracy and surface texture analysis. The cutting forces were measured using Kistler dynamometer. Dynamometer works on the principle of peizo-electricity where it senses the forces induced during the machining and send this back in form of peizo-electric signals to the amplifier, which converts data to be displayed in form of graph. Dynoware software was used with the Kistler dynamometer to study the cutting forces during machining operations. Post machining process consists of cutting force, surface texture and dimensional accuracy analysis of the Ti-6Al-4V alloy. Surface roughness (R_a) measurement of the machined titanium block was performed using Alicona 3D Surface profilometer.

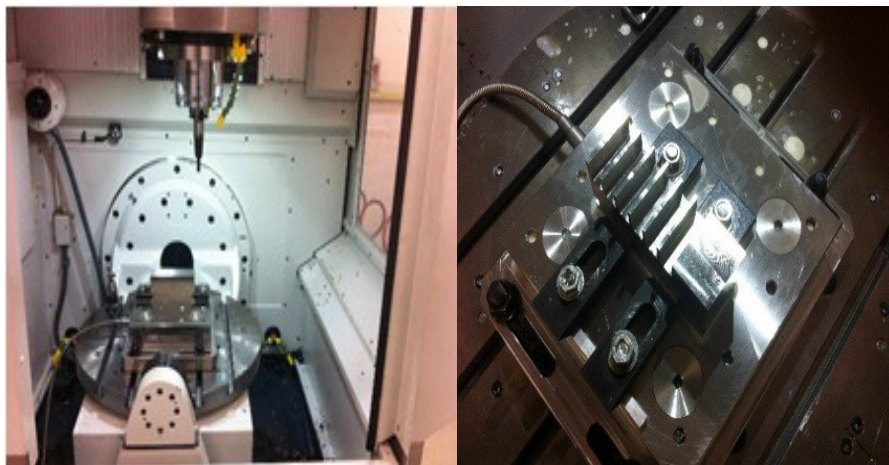

Fig 4. Experimental set-up for thin-wall machining

Table 1. Chemical Composition of Ti-6Al-4V

Chemical Composition	V	Al	Sn	Zr	Mo	C	Si	Cr	Ni	Fe	Cu	Nb	Ti
Weight (%)	4.22	5.48	0.0625	0.0028	0.1005	0.369	0.0222	0.0099	<0.001	0.112	<0.02	0.0386	90

Table 2. Mechanical Properties of Ti-6Al-4V

Work material	Ti-6Al-4V
Ultimate tensile Strength (MPa)	887
Modulus of elasticity (x10 ⁶ MPa)	11.3
Hardness (HRC/ 12mm/ 150 Kgf)	28-32

Table 3. Milling parameters of Ti-6Al-4V

Trial	Cutting Speed (V _c) m/min	Feed/tooth(F _z) mm/tooth	Step over (a _e) mm	Depth of cut (a _p) mm
1	90	0.25	0.20	20
2	90	0.25	0.30	20
3	90	0.35	0.20	20
4	90	0.35	0.30	20
5	120	0.25	0.20	20
6	120	0.25	0.30	20
7	120	0.35	0.20	20
8	120	0.35	0.30	20

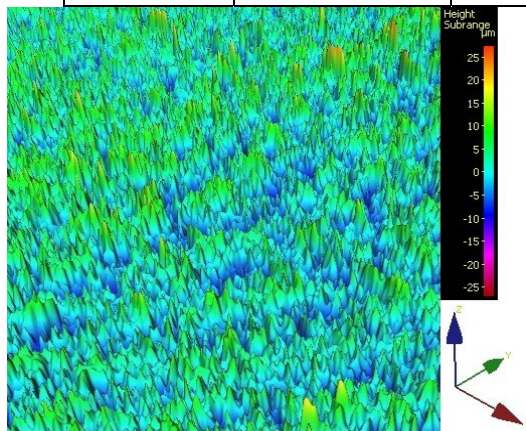

Fig 5. 3D surface profilometry of thin wall-trial 6

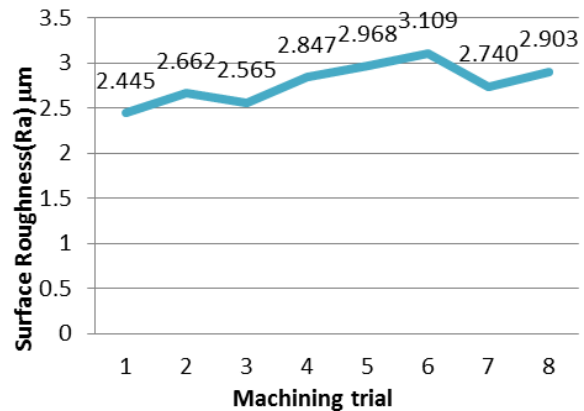

Fig 6. Surface roughness(R_a) for thin wall machining

Figure 5 shows a sample 3D image of the peak and valleys constituting the surface texture of the machined sample. The surface roughness measurement was done using 3D optical surface profilometer where images were taken by the instrument using a magnification lens and image analysis is done by the instrument software, measurement suite, to give a Ra value for the chosen area of focus. Surface finish obtained in case of titanium casted or sintered parts is roughly in the range of 5-10 μm [13]. Surface roughness was measured for an area of 5mm² at three random spots for each trial. As an optical profilometer was used. A consistency was maintained in the selected surface area of 5 mm² for all measurement trials. The dimensional accuracy analysis of the machined part was carried out with respect to the wall thickness. The thickness of the wall was measured in the start, mid and end section of the thin wall and average value was derived to represent the whole part. The error in wall thickness was

calculated by subtraction of actual thickness (5mm) from the observed thickness after machining.

5. Results and Discussion

The measured cutting forces during machining of Ti-6Al-4V alloy are plotted in form of a graph as shown in Fig.7. The highest force was measured during trial 6 which consists cutting speed of 120 m/min, feed/tooth of 0.25 mm/tooth and step over of 0.3 mm.

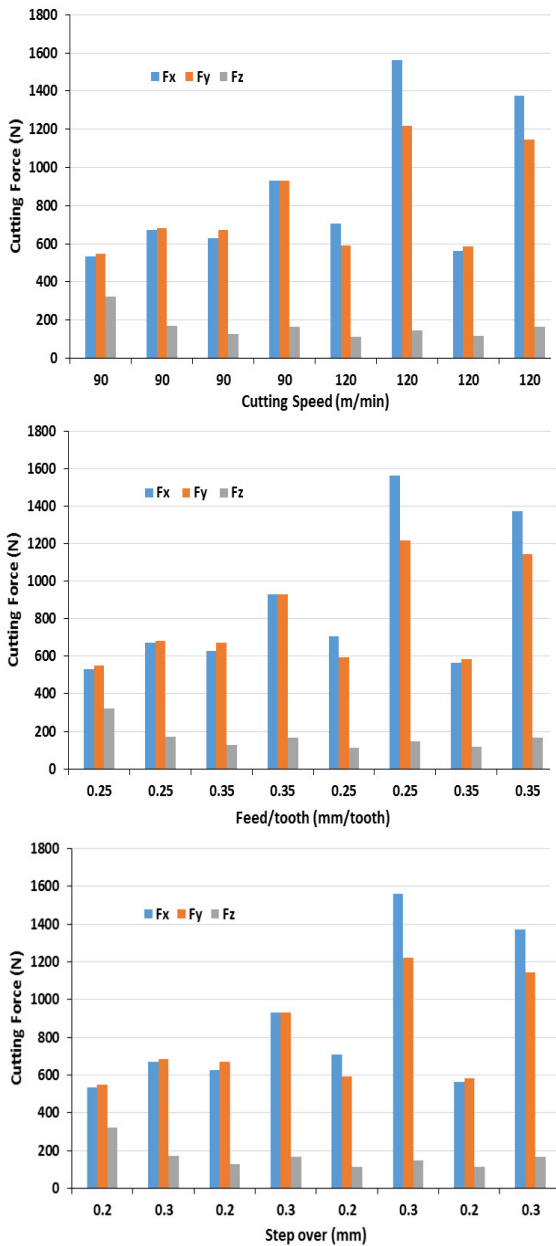

Fig.7 Cutting force variations for thin wall machining

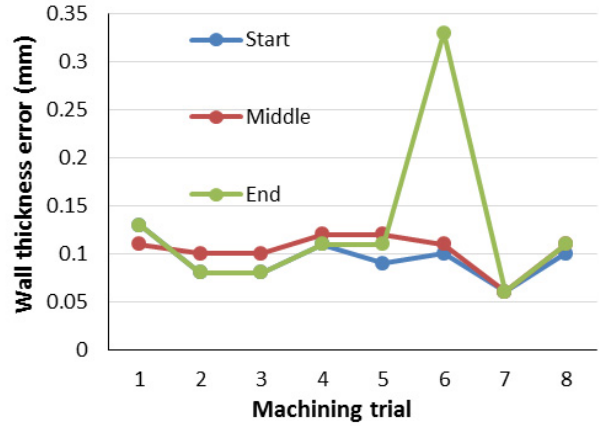

Fig 8. Dimensional accuracy for thin wall machining

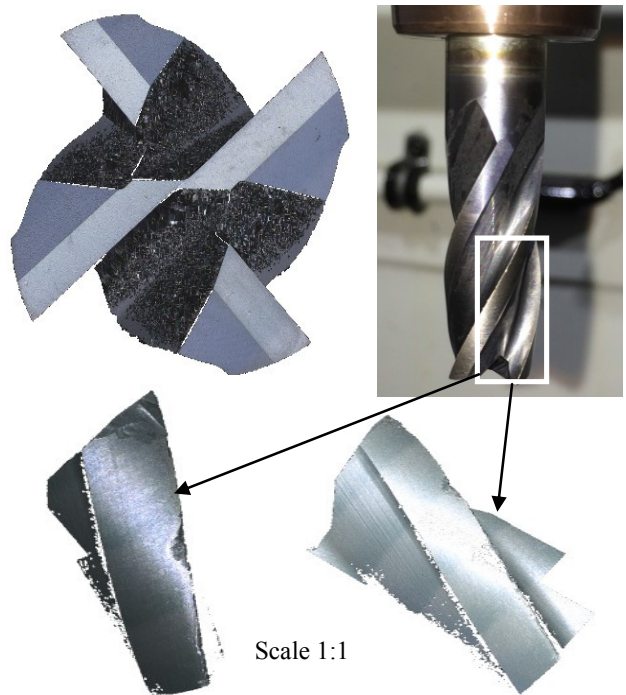

Fig 9. Tool Wear image after trial6 using an optical profilometer

The other reason for the high cutting force can also be due to the tool wear reaching its maximum limit during this trial as shown in fig.9. The cutting forces shows a direct relationship with the cutting speed, feed/tooth and step over. From the experiment it has been studied that the tool wear is more in case of low speed machining compared with high speeds. In case of trochoidal milling, the stress on cutting edge also increases with the increase of cutting speeds due to the increase of contact length. Flute length of tool is 22 mm whereas overall length is 73mm. It is noted that periods of large force fluctuations (dynamic force) occurred randomly during machining Ti-6Al-4V. These fluctuations make the tool to vibrate which would result in early tool failure.

The fluctuations in cutting forces are evident more when the feed is large and high cutting speed. The trochoidal milling also shows a unique observation with respect to the direction of cutting forces as it keeps reversing for every 180 degrees of rotation of the tool producing a sinusoidal pattern. As explained earlier in experimental design, the dimensional accuracy of the thin wall is the difference in actual wall thickness and observed wall thickness after machining. This criteria is a means to convey information on deformation (δ) of thin wall if any, which is quite common in thin-wall machining. This trend is more dominant in machining wall of thickness ≤ 5 mm. The dimensional accuracy variations for all machining trials is shown in fig.7. It is observed that cutting force in addition to tool wear plays an important in maintaining the dimensional accuracy of the part. Better dimensional accuracy was observed for lower cutting speeds and vice-versa for higher speeds. The dimensional accuracy in case of trial 6 with maximum tool wear was off limit to a greater extent. The parameter, surface roughness (R_a) was measured as part of the surface texture analysis. Fig 6 shows the surface roughness variations for the machining trials. Surface roughness (R_a) was highest for trial 6, where the trochoidal milling was done at cutting speed of 120 m/min feed/tooth of 0.25 mm/tooth and step over of 0.3 mm. Generally, tool wear and coolant usage does influence the surface finish. In this case, as coolant was used for all the trials and hence, effect of coolant was assumed to be constant on all trials. As stated earlier, trial 6 is the point where the cutting tool has reached the maximum tool wear limit. This is can also be an added reason for the poor surface finish. A direct relationship has been established between surface roughness (R_a) and the cutting parameters, especially feed rate and step over. The physical appearance of the machined surface is loaded with concentric circles (feed marks). Especially for trochoidal milling as it involves tool rotation with a translation movement. The intensity of the marks keep increasing as the feed and step over increase. The inferences from the cutting force analysis corroborate with the surface roughness analysis. Overall, the machinability of the titanium alloy Ti-6Al-4V for thin wall machining using trochoidal milling was assess with respect to cutting force, dimensional accuracy and surface texture analysis. After analysing the results obtained, the machinability of the material was considered to be satisfactory with certain limitation which needs further investigation in order to improve. The positive inferences relevant to thin wall machining using trochoidal milling are increase in productivity due to almost full engagement of the cutting length. The limitations are the poor heat dissipating capacity from the cutting zone, rapid tool wear and effect of coolant.

6. CONCLUSION

An experimental investigation was carried out to evaluate the machinability of the titanium alloy Ti-6Al-4V for thin wall machining using trochoidal milling which helps to improve the Ti-6Al-4V productivity in aerospace industries. By conducting the trochoidal type milling of Ti-6Al-4V alloy following results were concluded:

- Cutting forces in x, y, z direction increases as cutting parameters-speed, feed/tooth and step over increases. The cutting force is maximum for trial6 where trochoidal milling is done at cutting speed of 120 m/min, feed/tooth of 0.25 mm/tooth and step over of 0.3mm.
- Cutting force is higher in case of high cutting speed compared to low cutting speed, which likely resulted in higher tool wear. Tool wear should be low enough to acquire high productivity. The maximum cutting forces was recorded at high cutting speed with a large step over.
- Better dimensional accuracy was observed for lower cutting speeds and vice-versa for higher speeds. The dimensional accuracy in case of trial 6 with maximum tool wear was off limit to a greater extent.
- Surface roughness (R_a) was highest for trial 6, where the trochoidal milling was done at cutting speed of 120 m/min feed/tooth of 0.25 mm/tooth and step over of 0.3 mm.
- The inferences from the cutting force analysis corroborate with the surface roughness analysis.

- The positive inferences relevant to thin wall machining using trochoidal milling are better surface finish at low feed rate (below 0.25 mm/tooth). An increase in productivity due to almost full engagement of the cutting tool length. The limitations are rapid tool wear and effect of coolant.
- The machinability of the material was considered to be satisfactory with certain limitation which needs further investigation in order to improve.

7. Future Work

The future work consists of conducting post machining analysis such as Chip morphology analysis, Metal Removal Rate (MRR) analysis, tool wear analysis and metallographic analysis. Tool wear analysis is done using Alicona 3D tool wear measurement, where an unworn tool and worn tool are superimposed and the tool wear is calculated using difference analysis imbedded in the instrument software. Metallographic analysis is done in order to check for any phase transformational reaction taking place at the microstructure level. MRR analysis is often used in production environment to check the productivity and hence, MMR analysis is done to optimize the cutting parameters and ensure maximum productivity.

References

1. Henriques, V.A.R., et al., *Production of titanium alloys for advanced aerospace systems by powder metallurgy*. Materials Research, 2005. **8**: p. 443-446.
2. Lei, S. and W. Liu, *High-speed machining of titanium alloys using the driven rotary tool*. International Journal of Machine Tools and Manufacture, 2002. **42**(6): p. 653-661.
3. Noland, D., W. Sebring, and Y. Bruhis, *High Performance Milling in Aerospace Materials*, in *Niagara Cutters*. 2001.
4. Emsley, J., *Titanium- Nature's Building Blocks: An A-Z Guide to the Elements*. 2001, Oxford, England, UK: Oxford University Press.
5. Che-Haron, C.H. and A. Jawaid, *The effect of machining on surface integrity of titanium alloy Ti-6% Al-4% V*. Journal of Materials Processing Technology, 2005. **166**(2): p. 188-192.
6. Lütjering, G. and J.C. Williams, *Titanium*. Vol. 2. 2003: Springer.
7. Donachie, M.J., *Titanium: a technical guide*. 2000: ASM international.
8. Krebs, R.E., *The history and use of our earth's chemical elements: a reference guide*. 2006: Greenwood Publishing Group.
9. Boyer, R., *An overview on the use of titanium in the aerospace industry*. Materials Science and Engineering: A, 1996. **213**(1): p. 103-114.
10. Sandvik Coromant, *Modern Metal Cutting*. 1994, Sandviken Sweden: A B Sandviken Coromant.
11. ABDULLAH, R.I.R., *Hybrid Deflection Prediction for Machining Thin-Wall Titanium Alloy Aerospace Component*. 2011, RMIT University.
12. *Thin Wall Machining-New Heights in Aerospace Realized Through Advanced High-Speed Machining Process*. [cited 2013 6/11]; Available from: <http://www.makino.com/about/news/thin-wall-machining/171/#sthash.f0KE0khO.dpuf>.
13. Duleba, B., *MATERIALS & FINISHING METODS OF DMLS MANUFACTURED PARTS*.