

Design and Implementation of a Microcontroller Based Buck Boost Converter as a Smooth Starter for Permanent Magnet Motor

S. Ravi^{1*}, Vitaliy Mezhuhev², K. Iyswarya Annapoorani³, P. Sukumar⁴

¹Faculty of Electrical Engineering, Botswana International University of Science & Technology, Palapye, Botswana

²Faculty of Computer Science and Software Engineering, University of Malaysia Pahang, Pahang, Malaysia

³Faculty of Electrical Engineering, VIT University, Chennai, India

⁴Faculty of Electronics and Communication Engineering, Nandha Engineering College Erode, India
e-mail: drraveeee@gmail.com

Abstract

This proposal proposes a DC/DC Buck Boost converter which has been used as a smooth starter for a DC Permanent Magnet Motor. In the existing system the DC/DC Buck Converter is used which provide the output less than the input Signal. Using buck converter it is difficult to increase the value of the input signal. Hence DC/DC Buck- Boost Converter used from which it is possible to get both the increased and decreased output from the given input. Previously pulse width modulation signals with respective to motor voltage is used. However they produce variations in the voltage and current of the motor. The above problem is overcome by using DC/DC Power converter. The proposed system with reduction in size, reduced ripples and increase in speed makes the system to operate at both low and high power applications. The proposed system results in higher efficiency, reduces the ripple content and the stress. The results are validated through MATLAB/Simulink and real time implementation.

Keywords: Buck Boost Converter, Permanent Magnet Motor, Pulse Width Modulation, Motor

1. Introduction

DC/DC Buck- Boost Converter from which we can obtain both the increased and decreased form of output from the given input. These converters overcome the variations in the voltage and current of the motor [1-4]. PIC controllers are microcontrollers they are used in electronic circuits that can be programmed to carry out a vast range of task. They programmed to be timers or to control a production line and much more. They are reliable and malfunctioning of PIC percentage is very less. And performance of the PIC is very fast because of using RISC architecture [5]. Power conception is also very less when compared to other micro controllers. Programming is also very easy when compared to other microcontrollers. DC/DC buck boost Converter, Battery, Diode, Capacitor, MOSFET, Controller, PIC 16F series, DC Motor, Optical encoder are involved in this project. In this project a 7801 regulator is used [6-7]. The regulator input voltage is obtained from the DC source and the regulated output of 5v is given to the PIC microcontroller to the DC Source. The DC supply is given to the MOSFET. During ON state the switch is closed and supplies current to the inductor and capacitor to load. During OFF state the switch is opened and the inductor supplies the current to the load via the diode. The gate pulse is connected to a gate driver. Based on the duty cycle the converter acts as either buck or boost converter. When the duty ratio is less than 50% than it act as a buck converter and above 50% it act as a boost converter. The gate driver is a power amplifier that accepts a low power input from a controller IC and produces a high current drive input for the gate of a high power transistor such as power MOSFET. The resistors used in gate driver circuit to resist the flow of current. The output of the gate driver is given to the PIC controller. An IR LED and a IR receiver are connected across the motor shaft. During motor rotation the signal path is cut by the shaft from which the speed is measured. Hence photo diode is used to measure the speed of the motor. The pulse signal from the photo diode is given to the PIC controller. It is possible by using PIC controller which achieves favorable properties like a smooth starting DC permanent magnet motor using a buck boost converter [8-9].

The proposed system can be used in industry and high power applications, the system efficiency is increased. Simulation results show that the current ripple in the input and output circuits is less. This increases the linearity. This project concentrates on the various design aspects, steady state and transient response, device selection, operating principle, gating pattern and the various waveforms. The main objective of this project is to clearly study about the starting of dc motor using buck boost converter and its implementation.

In the existing system dc/dc buck converter [10-11] is used as a smooth starter for a dc permanent magnet motor [1]. This is achieved by controlling the step less velocity and smoothness, adjustment of the armature voltage of the dc permanent magnet motor. For the angular velocity trajectory tracking task a hierarchical controller is designed. Hierarchical controller consists of two controllers. One for dc motor and another for a dc/dc buck boost converter. The controller used for dc motor is differential flatness control and cascade control scheme is used for buck boost converter.

The sliding mode control (SMC) and proportional-integral (PI) control are interconnected to form a cascade control. The hierarchical controller is tested using MATLAB-Simulink and the DS1104 board from Dspace. The obtained results show that the desired angular velocity trajectory is well tracked under abrupt variations in the system parameters and that the controller is robust in such operation conditions, confirming the validity of the proposed controller. The Figure 1 shows the block diagram of the existing system.

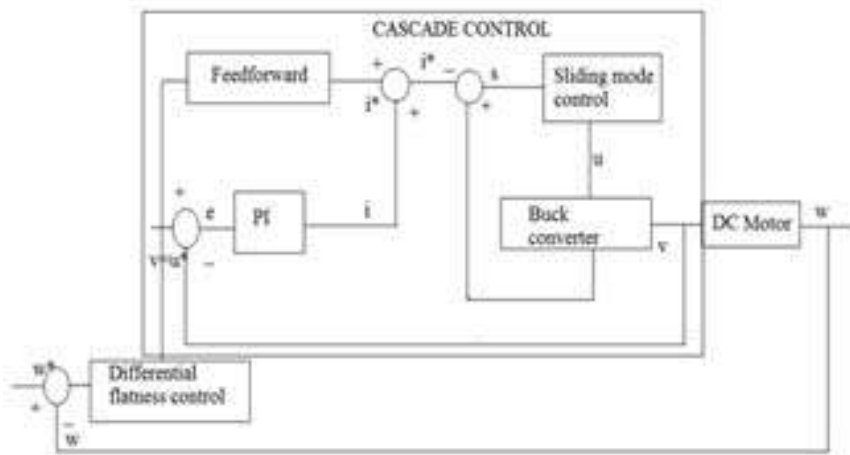

Figure 1. Block diagram of the existing system

The existing system has more switching loss. In the existing system the effectiveness of the proposed controllers were verified only by numerical simulations. In the existing system the DC/DC Buck Converter is used which provide the output less than the input Signal [6]. Similarly for PI Controller, PIC Controller is used. PIC controller provides fast response and accurate results.

The proposed method is used to improve converter performance in terms of efficiency, size, conducted electromagnetic emission and transient response. To minimize the amount of ripples, a new IBC has been proposed in addition to which it has improved performance characteristics of higher power capability, reduced duty ratio and improved reliability, modularity. Block diagram of the proposed system is shown in Figure 2. However the buck boost converter improves converter performance at the cost of additional inductors, switching devices and controllers.

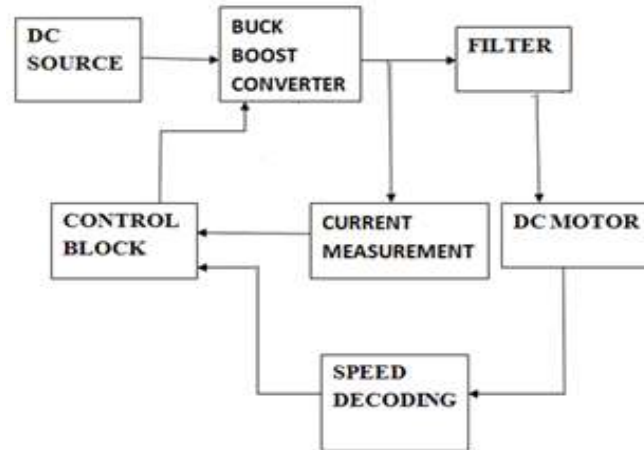

Figure 2. Block diagram of the proposed system

2. Block Diagram Explanation

The regulator input voltage is obtained from the DC source and the regulated output of 5v is given to the PIC microcontroller to the DC Source. The DC supply is given to the MOSFET. During ON state the switch is closed and supplies current to the inductor and capacitor to load. During OFF state the switch is opened and the inductor supplies the current to the load via the diode. The gate pulse is connected to a gate driver. Based on the duty cycle the converter acts as either buck or boost converter. When the duty ratio is less than 50% than it act as a buck converter and above 50% it act as a boost converter.

The gate driver is a power amplifier that accepts a low power input from a controller IC and produces a high current drive input for the gate of a high power transistor such as power MOSFET. The resistors used in gate driver circuit to resist the flow of current. The output of the gate driver is given to the PIC controller. An IR LED and a IR receiver are connected across the motor shaft. During motor rotation the signal path is cut by the shaft from which the speed is measured. Hence photo diode is used to measure the speed of the motor. The pulse signal from the photo diode is given to the PIC controller. It is possible by using PIC controller which achieves favorable properties like a smooth starting DC permanent magnet motor using a buck boost converter.

2.1. Buck Boost Converter

A Buck-Boost converter is a type of switched mode power supply that combines the principles of the Buck Converter and the Boost converter in a single circuit. Like other SMPS designs, it provides a regulated DC output voltage from either an AC or a DC input. The Buck converter described in Power Supplies Module produces a DC output in a range from 0V to just less than the input voltage. The boost converter will produce an output voltage ranging from the same voltage as the input, to a level much higher than the input.

There are many applications however, such as battery-powered systems, where the input voltage can vary widely, starting at full charge and gradually decreasing as the battery charge is used up. At full charge, where the battery voltage may be higher than actually needed by the circuit being powered, a buck regulator would be ideal to keep the supply voltage steady. However as the charge diminishes the input voltage falls below the level required by the circuit, and either the battery must be discarded or re-charged; at this point the ideal alternative would be the boost regulator described in Power Supplies Module By combining these two regulator designs it is possible to have a regulator circuit that can cope with a wide range of input voltages both higher and lower than that needed by the circuit. Fortunately both buck and boost converters use very similar components; they just need to be re-arranged, depending on the level of the input voltage.

2.2. PIC Controller

PIC Controller is Peripheral Interface Controller. PIC controllers are microcontrollers they are used in electronic circuits that can be programmed to carry out a vast range of task. They programmed to be timers or to control a production line and much more. They are reliable and malfunctioning of PIC percentage is very less. And performance of the PIC is very fast because of using RISC architecture. Power conception is also very less when compared to other micro controllers. In the programmer point of view interfacing is very easy, also possible to connect analog devices directly without any extra circuitry. Programming is also very easy when compared to other microcontrollers.

The buck boost converter produces both increased and decreased form of output from the given input. PIC controllers are microcontrollers they are used in electronic circuits that can be programmed to carry out a vast range of task. They programmed to be timers or to control a production line and much more. They are reliable and malfunctioning of PIC percentage is very less. And performance of the PIC is very fast because of using RISC architecture. Power conception is also very less when compared to other micro controllers. Programming is also very easy when compared to other microcontrollers. The circuit diagram of the three phase interleaved boost converter is shown in Figure 3.

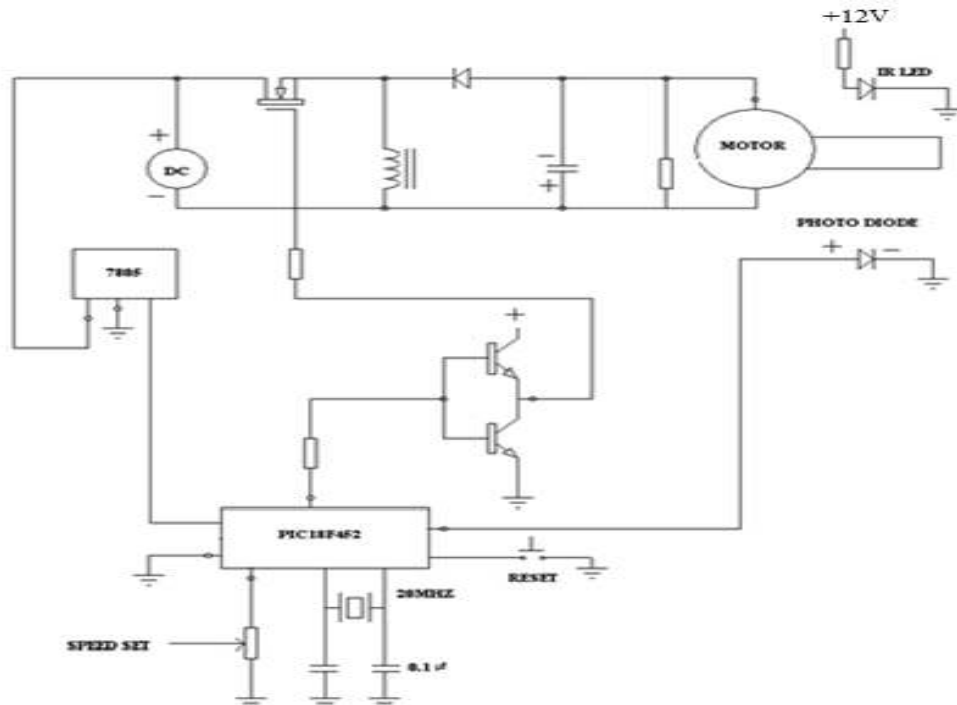

Figure 3. Circuit diagram for three phase interleaved boost converter

3. MATLAB Simulation and Hardware Implementation

The proposed system simulated using MATLAB/Simulink. The buck boost converter model having three MOSFETs as switches. The Figure 4 shows the simulation diagram of the overall system. It consists of PIC controller, subtract, reference voltage, step input, inductor, capacitor, pulse generator blocks and controlled voltage source. Initially the step block generates the step input, which is given to the controlled voltage source block. The controlled voltage source block converts the simulink input signal into an equivalent voltage source. The generated voltage is driven by the input signal of the block. The gate pulse generator generates the pulse and given to the MOSFET. In this system buck boost converter is used as a smooth starter for a dc motor. The above diagram is the simulation circuit of this project. Here various blocks are used. The step block is used to obtain a dynamic response and to change the values during run time. Then the step block is connected to a gain to change the values in the form of

per unit gain value 1/20. The clock used for time correction. The function block performs the function based on the formula. Repeating sequence is provided to obtain the pulse signal. The rational operator compares the two functions and its output is connected to a scope. The signal from the rational operator is given to the gate of the MOSFET. The dc source is given to the switch. When the switch is closed the inductor is charged and the capacitor provides supply to the load. When the switch is open the supply is obtained from the inductor. The resistor used here to discharge the 300V supply is given to the field windings and a load torque of 10 N.m applied at 1 second is applied. A gain is used to convert rad/sec in terms of rpm. Finally the required speed, armature current and electrical torque is obtained. The Figure 5 and Figure 6 shows the buck, boost converter output for the proposed system. The Figure 7 shows the buck-boost converter output for the proposed system.

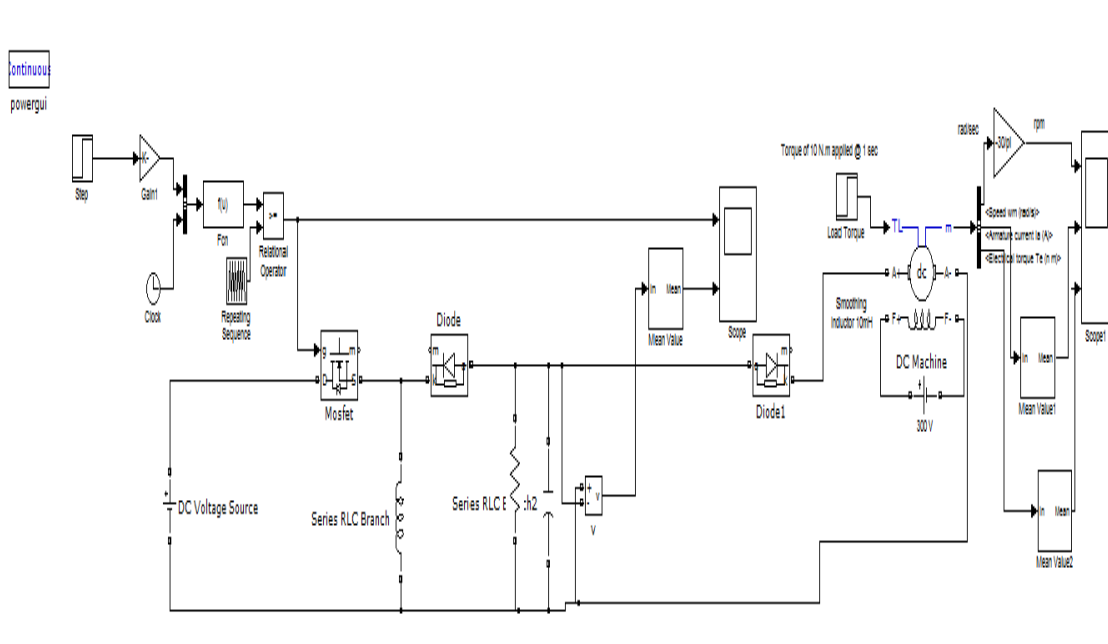

Figure 4. Simulation diagram of the overall system

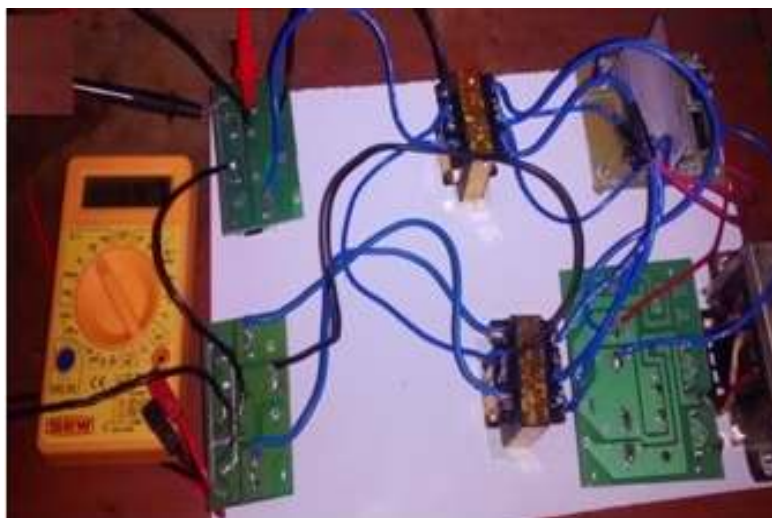

Figure 5. Buck converter output of the proposed system

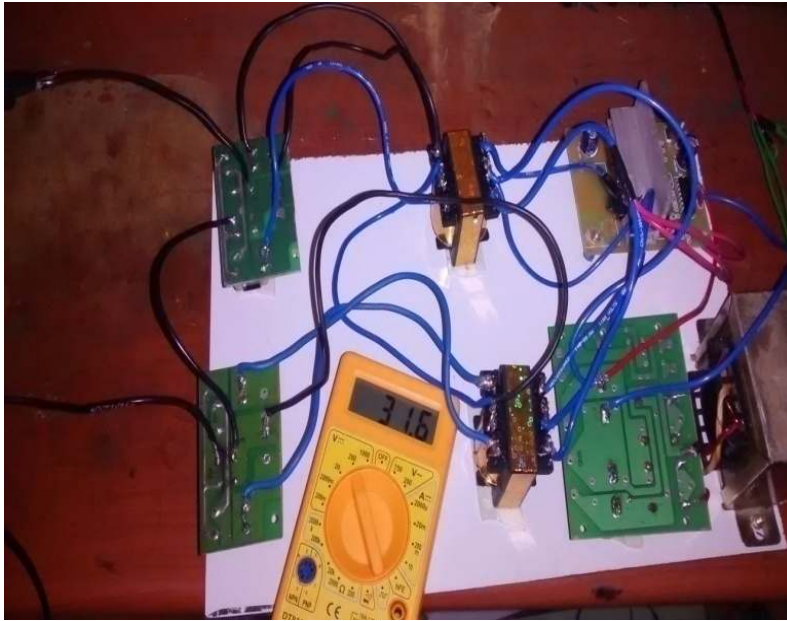

Figure 6. Boost converter output of the proposed system



Figure 7. Buck Boost converter output of the proposed system

4. Results and Discussion

The Figure 8 shows the buck boost converter output voltage. The performance of the system is measured with the time of 2 minutes. The simulation output between the voltage multiplier output voltage in volts and the time in minutes. At the time of 0.2 seconds, the output voltage reaches 326V. At 0.46 seconds the voltages reaches 350V and attains the constant value. The simulation output of the three phase interleaved boost converter with doubler circuit output voltage is shown in the Figure 9. The performance of the system is measured with the time of 5 minutes. The simulation output between the three phase interleaved boost converter output voltage in volts and the time in minutes. At the time of 0.01 seconds, the output voltage reaches 80V. And then falls into the constant value. The performance of the system is measured with the time of 2 minutes. The simulation output between the voltage multiplier output voltage in volts and the time in minutes. It reaches 380V constant at 0.42S and this is the

desired output voltage. The Figure 10 shows the motor speed waveform. The Figure 11 and Figure 12 shows the armature current and electric torque waveform. The Figure 13 shows the proposed system hardware output.

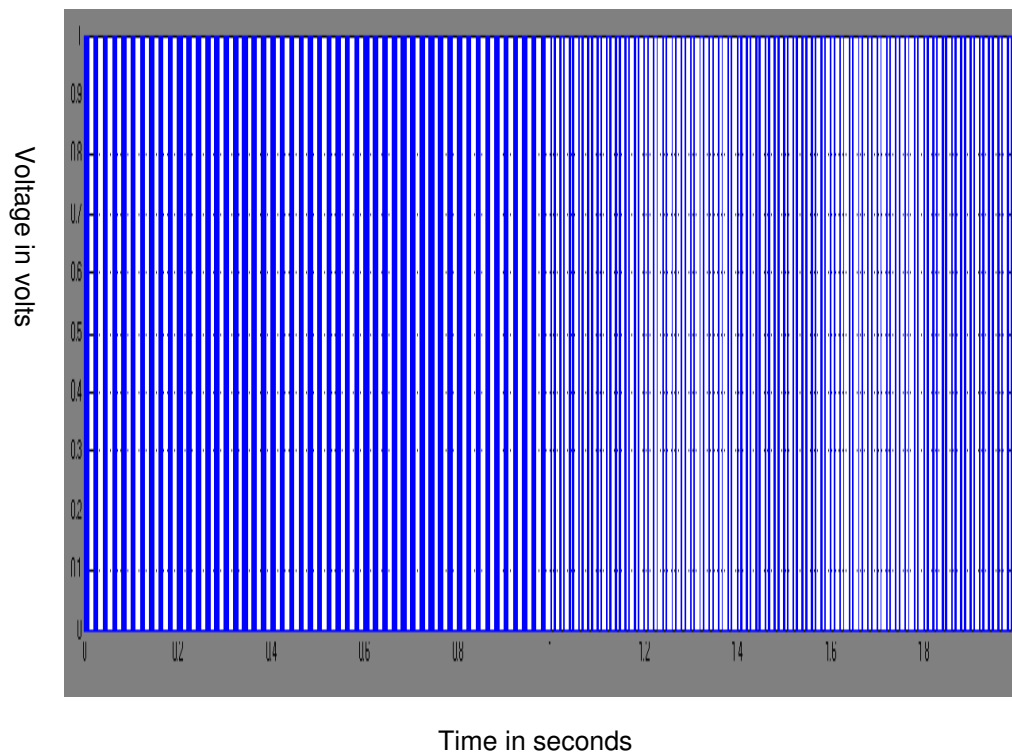

Figure 8. Buck boost converter input voltage



Figure 9. Buck boost converter output voltage

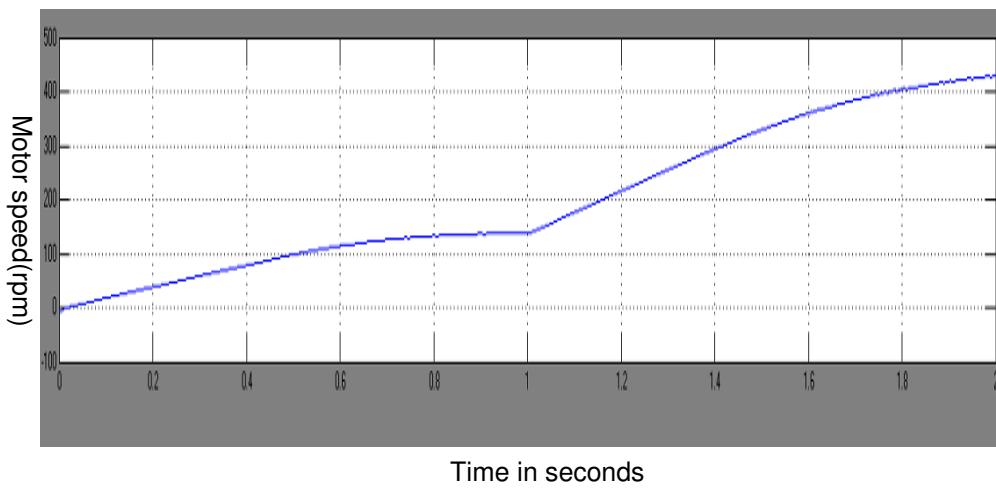

Figure 10. Motor speed wave form

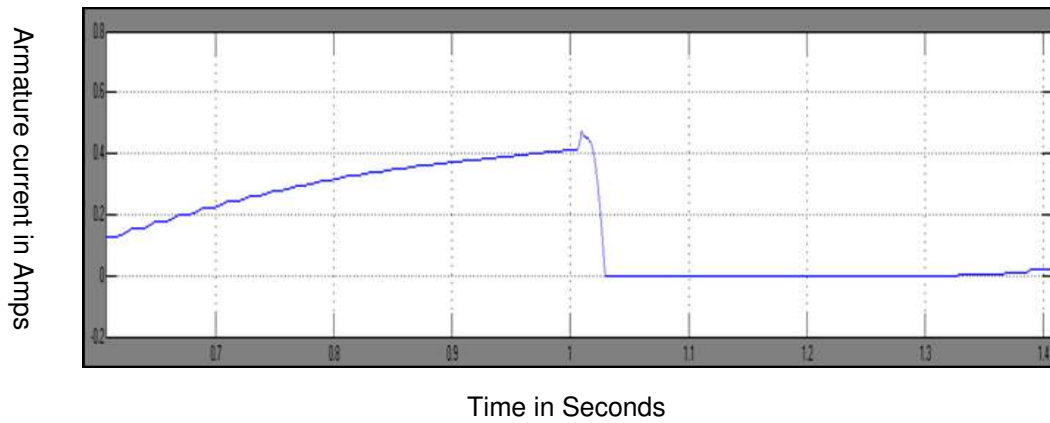

Figure 11. Armature current wave form

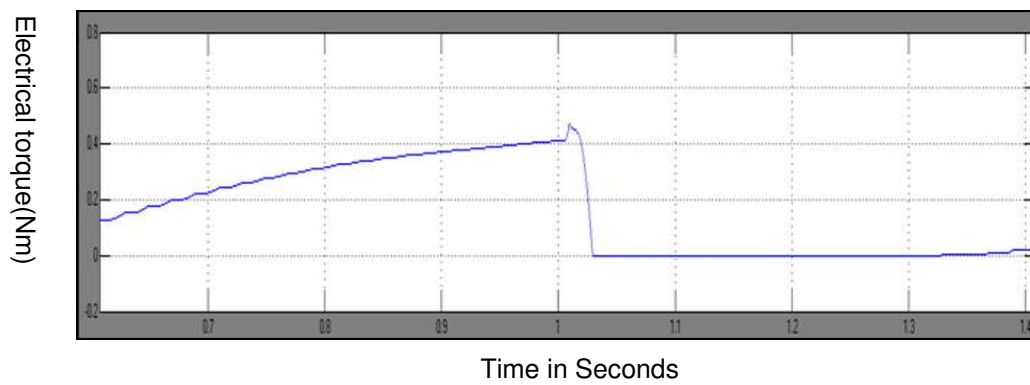

Figure 12. Electrical torque wave form



Figure 13. Final output voltage waveform of the proposed system

5. Conclusion

This paper presents the operation of DC/DC Buck Boost Converter act as a smooth starter for a DC Motor using a PIC Controller. PIC Controllers are reliable and malfunctioning of PIC percentage is very less. And performance of the PIC is very fast because of using RISC architecture. Power conception is also very less when compared to other micro controllers. The buck boost converter act as both buck and boost converter based on the duty cycle. Thus improvements to the efficiency of the proposed converter have achieved. The simulation model circuit has been developed; it proves that the proposed converter is having higher efficiency and reduced ripple content. The proposal increases the speed makes the system to work in both low and high power applications.

References

- [1] Ahmad MA, Raja Ismail RMT, Ramli MS. Control strategy of buck converter driven DC motor: a comparative assessment. *Australian Journal of Basic and Applied Sciences*. 2010; 4(10): 4893–4903.
- [2] Dingzhen Li, Haizhen Guo. Control Strategy of Three Phase PWM by Three Half Bridge Topology Bidirectional DC/DC Converter and Resonant. *TELKOMNIKA Indonesian Journal of Electrical Engineering*. 2014; 12(8): 6111-6118.
- [3] Linares Flores J, Barahona Avalos JL, Sira Ramirez H, Contreras-Ordaz MA. Robust passivity-based control of a Buck Boost converter/ DC-motor system: An active disturbance rejection approach. *IEEE Transaction on industry applications*. 2012; 48(6): 2362-2371.
- [4] Ravi S, Balakrishnan PA. Design of Synthetic Optimizing Neuro Fuzzy Temperature Controller for Dual Screw Profile Plastic Extruder Using Lab VIEW. *Journal of Computer Science*. 2011; 7(5): 671-677.
- [5] Linares Flores J, Sira Ramirez H. *A smooth starter for a DC machine. A flatness based approach*. Proceedings of the 1st International Conference on Electrical and Electronics Engineering, Mexico. 2004; 589–594.
- [6] Ravi S Balakrishnan PA. *Modelling and Control of an ANFIS Temperature Controller for Plastic Extrusion Process*. Proceedings of the 2010 IEEE International Conference on Communication Control and Computing Technologies India. 2010.
- [7] Linares Flores J, Sira Ramirez H. *Sliding mode-delta modulation GPI control of a DC motor through a buck converter*. Proceedings of the 2nd IFAC Symposium on System, Structure and Control, Mexico. 2004; 405–409.
- [8] Linares Flores J, Sira Ramirez H. *DC motor velocity control through a DC-to-DC power converter*. Proceedings of the IEEE 43rd Conf. Decis. Control, Atlantis, the Bahamas. 2004; 5: 5297– 5302.
- [9] Rajendra R Aparnathi, Ved Vyas Dwivedi. Design and Simulation Low Voltage Single-Phase Transformerless Photovoltaic Inverter. *TELKOMNIKA Indonesian Journal of Electrical Engineering*. 2014; 12(7): 5163-5173.
- [10] Dinghen Li, Haizhen Guo. Control strategy of Three phase PWM by three half bridge topology bidirectional DC/DC converter and resonant. *TELKOMNIKA Indonesian Journal of Electrical Engineering and computer science*. 2014; 12(8):6111-6118.
- [11] Chandani Sharma, Anamika Jain. Distributed MPP Tracking of PV through Buck converter using Fuzzy. *TELKOMNIKA Indonesian Journal of Electrical Engineering and computer science*. 2015; 15(2): 197-208.