

Intelligent Techniques and Evolutionary Algorithms for Power Quality Enhancement in Electric Power Distribution Systems

S.Prabhakar Karthikeyan, K.Sathish Kumar, I.Jacob Raglend and D.P.Kothari
*Vellore Institute of Technology, Vellore, Tamil Nadu
India*

1. Introduction

In the field of power system, equipments like synchronous machine, transformer, transmission line and various types of load occupies prime position in delivering power from the source to the consumer end. By the early 19th century, people were concentrating more on the quantity of power i.e active power which was the main issue and still researchers are working on various sources to meet out the exponentially increasing demand.

But now, the issue of power quality has started ruling the power system kingdom, where the frequency at which the active power is generated / pushed, the voltage profile at which the power is generated, transmitted or consumed and the reactive power which helps in pushing the active power plays a vital role. One main reason in emphasizing power quality is the amount of consumption of active power by the load i.e the efficiency of the system is decided by the quality of power received by the consumer. Any studies related to the above issues can be brought under the power quality domain.

2. Distribution systems

Power system is classified into generation, transmission and distribution based on factors like voltage, power levels and X/R ratio etc.

The well known characteristics of an electric distribution system are:

- Radial or weakly meshed structure
- Multiphase and unbalanced operation
- Unbalanced distributed load
- Extremely large number of branches and nodes
- Wide-ranging resistance and reactance values

2.1 Components of distribution system

In general distribution system consists of feeders, distributors and service mains.

2.1.1 Feeder

A feeder is a conductor which connects to the sub-station or localized generating station to the area where power is to be distributed. Generally no tapings are taken from the feeders so

current in it remains same through out. The main consideration in the design of a feeder is the current carrying capacity.

2.1.2 Distributors

A distributor is a conductor from which tapings are taken for supply to the consumers. The current through the distributors are not constant as tapings are taken at various places along its length. While designing a distributor, voltage drop along the length is the main consideration – limit of voltage variation is ± 6 Volts at the consumer terminal.

2.1.3 Service mains

A service main is generally a small cable which connects the distributor to the consumer terminals.

2.2 Connection schemes of distribution system

All distribution of electrical energy is done by constant voltage system. The following distribution circuits are generally used.

1. Radial system
2. Ring Main system
3. Inter connected system

2.2.1 Radial system

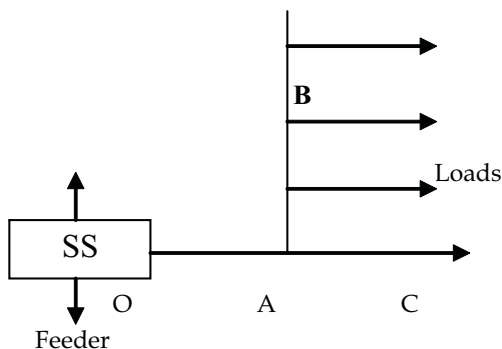

Fig. 1. Radial Distribution system

In this system shown in above figure separate feeder radiates from a single substation and feed distributors at one end only. Figure 1 shows the radial system where feeder OC supplies a distributor AB at point A. the radial system is employed only when the power is generated at low voltage and the sub-station is located at the centre of the load.

Advantages: This is the simplest distribution circuit and has a lowest initial cost. The maintenance is very easy and in faulty conditions very efficient to isolate.

Disadvantages:

1. The end of the distributor nearest to the feeding point will be loaded heavily.
2. The consumer at the farthest end of the distributor would be subjected to serious voltage fluctuations with the variation of the load.

3. The Consumers are dependent on a single feeder and single distributor. Any fault on the feeder or distributor cut-off the supply to the consumer who is on the side of fault away from the sub-station.

Due to these limitations this system is used for short distance only.

2.2.2 Ring main system

In this system each consumer is supplied via two feeders. The primaries of distribution transformer form a loop. The loop circuit starts from the sub-station busbar, makes a loop through the area to be served and returned to the sub-station.

Advantages:

1. There are less voltage fluctuations at consumer terminals.
2. The system is very reliable as each distributor is fed via two feeders. In the event of fault in any section of the feeder, continuity of the supply is maintained.

2.2.3 Interconnected systems

When the feeder ring is energized by two or more than two generating stations or sub-stations, it is called an interconnected system.

Advantages:

1. It increases the service reliability.
2. Any area fed from one generating station during peak load hours can be fed by other generating stations. This reduces reserve power capacity and increases the efficiency of the system.

2.3 Requirements for a good distribution system

1. The system should be reliable and there should not be any power failure, if at all should be for minimum possible time.
2. Declared consumer voltage should remain within the prescribed limits i.e. within +/- 6% of the declared voltage.
3. The efficiency of the lines should be maximum (i.e.) about 90%.
4. The transmission lines should not be overloaded.
5. The insulation resistance of the whole system should be high, so that there is no leakage and probable danger to human life.
6. The system is most economical.

2.4 Distribution System Automation (DSA)

Distribution System Automation is carried out all over the world to enhance the reliability of the distribution system and to minimize the huge losses that are occurring in the system. With the fast-paced changing technologies in the Distribution sector, the automation of distribution system is unavoidable. Feeder Reconfiguration (FR) is one of the vital operations to be carried out in successful implementation of the Distribution System Automation. FR can be varied so that the load is supplied at the cost of possible minimal line losses, with **increased system security and enhanced power quality**. Several attempts have been made in the past to obtain an optimal feeder configuration for minimizing losses in distribution systems.

This chapter gives us a clear picture about how intelligent techniques and evolutionary algorithms are used in the sub domains of the distribution systems where quality, quantity, continuous and reliable power can be made available to the consumers

2.5 Distribution feeder reconfiguration

Assessment of distribution system feeder and its reconfiguration using Fuzzy Adaptive Evolutionary computing

The aim of this section is to assess and reconfigure the distribution system using fuzzy adaptive evolutionary computing. Here, the reconfiguration problem can be subdivided into three modules, i.e.

- To detect the system abnormal operation based on S-difference criterion.
- Prioritize the transmission lines to re-route the power flowing through them as per the available transfer capacity.
- Reconfiguration of tie-line and sectionalizing switches using fuzzy adaptation of evolutionary programming.

2.5.1 S-difference criterion

This criterion is based on the apparent-power losses and uses only local data, i.e. voltage and current phasors at every line end in the system be proven that, at the voltage-collapse point, the entire increase in loading of the most critical line is due to increased transmission losses and that the power-loss sensitivities dP_L/dP , dP_L/dQ , dQ_L/dP and dQ_L/dQ go to infinity. Thus, in the vicinity of the voltage collapse, all increase in apparent-power supply at the sending end of the line no longer yields an increase in power at the receiving end

$$\Delta S(k+1) = \Delta U(k+1) * I(k) + \Delta I(k+1) * U(k) = 0 \quad (1)$$

Equation (1) can be rewritten as follows

$$1 + \Delta U_j(k+1) * I_{ji}(k) / U_j(k) * \Delta I_{ji}(k+1) = 1 + a e^{j\theta} = 1 + a(\cos\theta + j\sin\theta) = 0 \quad (2)$$

The proposed criterion is defined as the real part of the phasor as follows:

$$SDC' = \text{Re}(1 + a e^{j\theta}) \quad (3)$$

At the point of the voltage collapse, when $\Delta S = 0$, the criterion equals to zero.

2.5.2 Available Transfer Capability

Available transfer capability (ATC) is a measure of transfer capability remaining in the physical transmission network for future commercial activity over and above already committed uses. Mathematically, ATC is:

$$ATC = TTC - BCF - TRM - CBM \quad (4)$$

Where,

- TTC=total transfer capacity,
- TRM=transient reliability margin.
- CBM= capacity benefit margin.
- BCF=Base case flow.

2.5.3 ATC calculation through Linear Distribution Factor method

In the linear ATC model considered here PTDF and OTDF are not taken into account with line reactance. The linear ATC has been modified from distribution system point of view i.e. PTDF and hence ATC has been calculated by taking real power into account instead of using

line reactance. Some linear distribution factors based on DC model are introduced here to calculate linear ATC.

Power Transfer Distribution Factors (PTDF): In a bilateral transaction ΔT_{mn} between a seller bus m and buyer bus n , further consider a line (let the line be connected between the buses i and j) carrying a part of the transacted power P . For a change in real power transaction between areas, say by ΔT_{mn} , if the change in transmission line quantity is P_{ij} , then the power transfer distribution factor can be defined as:

$$(PTDF)_{ij-mn} = \Delta P_{ij} / \Delta T_{mn} \tag{5}$$

Line Outage Distribution Factors (LODF): LODF describes the impact of one branch outage on magnitude and direction of the power flow on the other branches. . In case of the outage of another branch l' (let the line be connected between the buses r, s) having pre-outage real power flow P_{rs} , Let P_{ij-rs} be the post outage flow in a line connected between the buses i, j . The LODF can be defined as the ratio of real power flow change in line l to the real power flow transmitted in the line taken for outage

$$(LODF)_{ij-rs} = (P_{ij-rs} - P_{ij}^0) / P_{rs}^0 \tag{6}$$

Outage Transfer Distribution Factor (OTDF): OTDF describes the effect of power interchange between areas on branch power flow on occasion of one branch outage.

$$(OTDF) = PTDF_{ij-mn} + LODF_{ij-rs} * PTDF_{rs-mn} \tag{7}$$

Thermal limits constrained ATC can be expressed as:

$$ATC_{mn-ij} = (P_{ij}^* - P_{ij}^0) / PTDF_{ij-mn} \tag{8}$$

Where, p_{ij}^* is the thermal limit of branch L . ATC calculated based on the combination of PTDF and LODF, can be expressed as:

$$ATC_{mn-rs} = (P_{ij}^* - P_{ij}^0) / OTDF \tag{9}$$

In conclusion, ATC is defined as:

$$ATC = \min \{ATC_{mn-ij}, ATC_{mn-rs}\} \tag{10}$$

Where NL is the total number of branches, and No is the total number of flow gate contingencies.

2.5.4 Reconfiguration using Fuzzy Adaptive Evolutionary computing

For reconfiguration purpose of the assessed system, Fuzzy adaptation of evolutionary programming (FEP) has been considered. The idea behind the adaptation of this particular method is to take into consideration the grey area between the various parameters considered in reconfiguration.

Real power loss minimization: To determine best combination of branches of resulting RDS which incur minimum loss

$$kV_{min} = V_{ss} \sum (V_{ss} - V_j) Y_{ssj} - \sum PD_j \tag{11}$$

where, $V_{jmin} \leq V_j \leq V_{jmax}$ &

V_{ss} = voltage at main station

Y_{ss} =admittance b/w main station and bus j

PD_j =Real power load at bus j

Improvement of power quality: To quantify the minimum limit violation imposed on voltages at buses voltage deviation index (VDI) is defined

$$VDI = \sqrt{(\sum N_{VB} V_{li} - V_{lim})^2 / N} \quad (12)$$

where,

N_{VB} = number of buses violating limit

V_{lim} = upper limit of the voltage

Fuzzy model of kW loss minimization objective: It defines the objective function that associates the satisfaction level with solution vector X_j

$$\mu_L = (P_{Lmax} - fpl(x_j)) / (P_{Lmax} - P_{Lmin}) \quad (13)$$

Where, P_{Lmax} =maximum loss;

P_{Lmin} =minimum loss,

$fpl(x_j)$ = power loss corresponding to X_j

Fuzzy model of VDI: It defines the objective function that associates the VDI level with solution vector X_j

$$\mu_V = (VD_{max} - fvd(x_j)) / (VD_{max} - VD_{min}) \quad (14)$$

Where, VD_{max} =maximum deviation

VD_{min} =minimum deviation

fvd =VDI corosponding to X_j

Development of a fuzzy evaluation method of the solution vector: The resultant satisfaction parameter associated with a solution X_j is determined as below.

$$\mu_r = \mu_L \times \mu_V \quad (15)$$

2.5.5 Case study

Simulation has been performed on the Vellore Bus system (Figure 2). It contains 75 buses and radial in configuration. For simulation purpose the system is assumed to be a balanced network with a generator at bus 1. Simulation has been carried out using MATLAB 6.5.

2.5.6 Simulation & results

SDC & ATC: SDC is calculated on 5th bus of Vellore 75 bus system as shown in Figure 2. From graph(Figure 3a & 3b), the voltage on the 5th bus is decreasing correspondingly the real part of the SDC is also decreasing but since there is no voltage collapse here so real part of SDC is not equal to Zero.

Whereas on bus 45 it can be seen from the graph (Figure 4a & 4b) that at voltage collapse point the real part of SDC is going below zero.

Available Transfer capability (ATC) is calculated on different buses for different loads when line between bus4 - bus5 has tripped to calculate the Line Outage Distribution Factors. . Here the thermal limit is taken as 4.7 MVA.

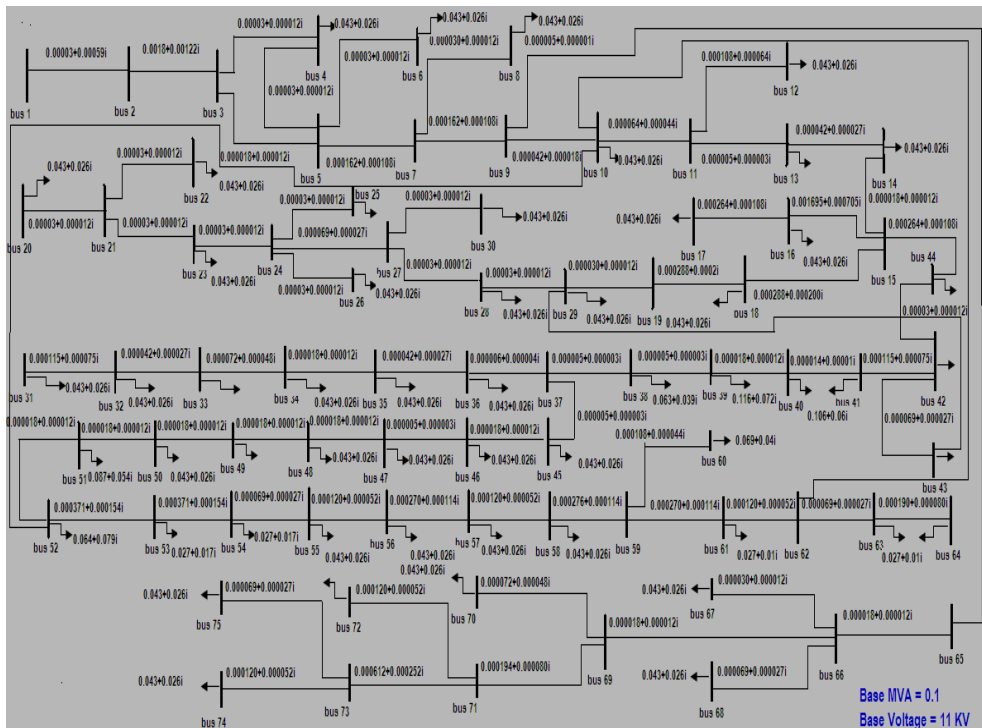

Fig. 2. 75 bus Vellore Distribution system

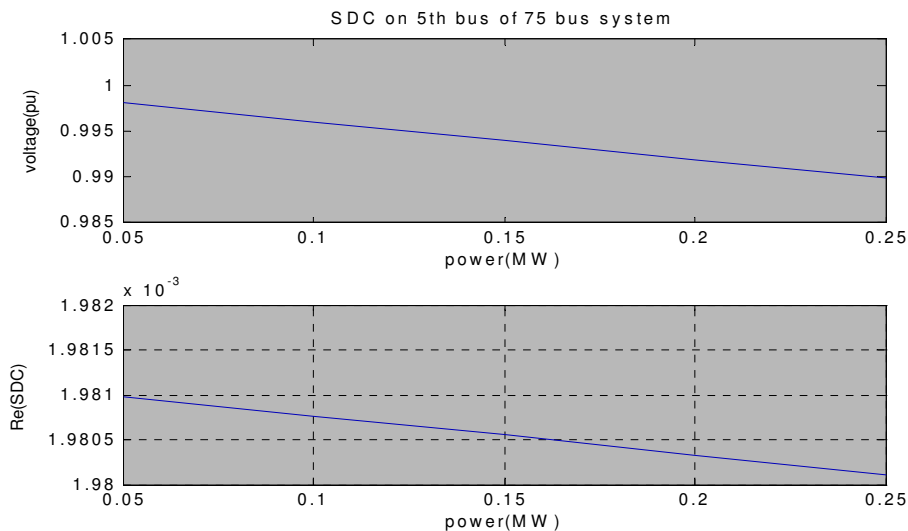

Fig. 3. a & b Re (SDC) Vs Increase in real load at 5th bus in 75-bus system

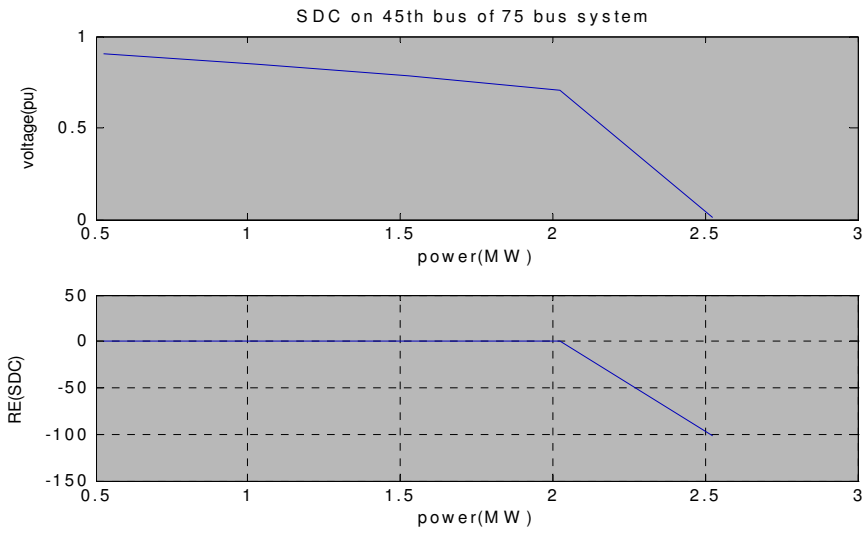

Fig. 4. a & b Re (SDC) Vs Increase in real load at 45th bus in 75- bus system

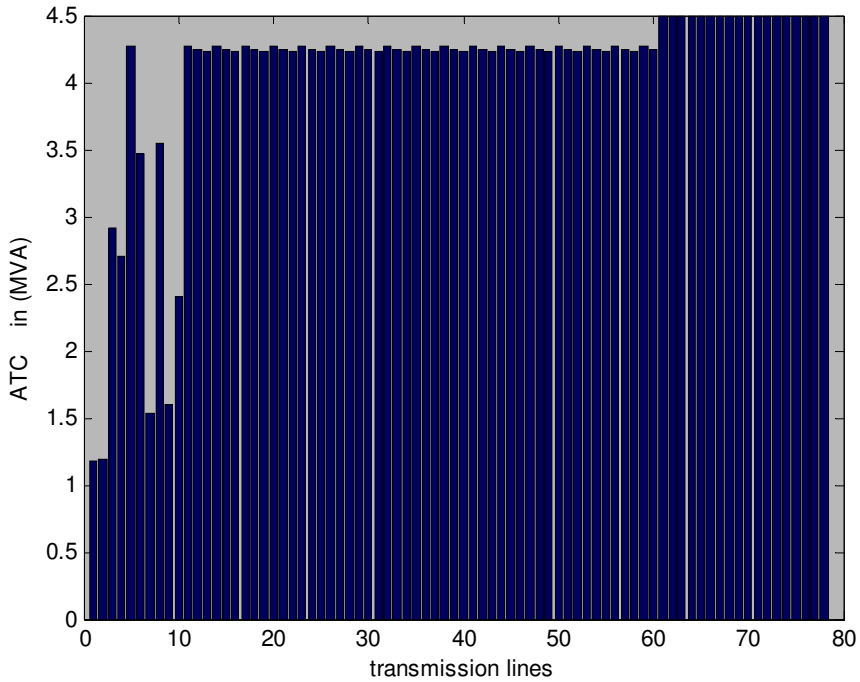

Fig. 5. ATC after removing line 4-5 & increasing load on bus 10

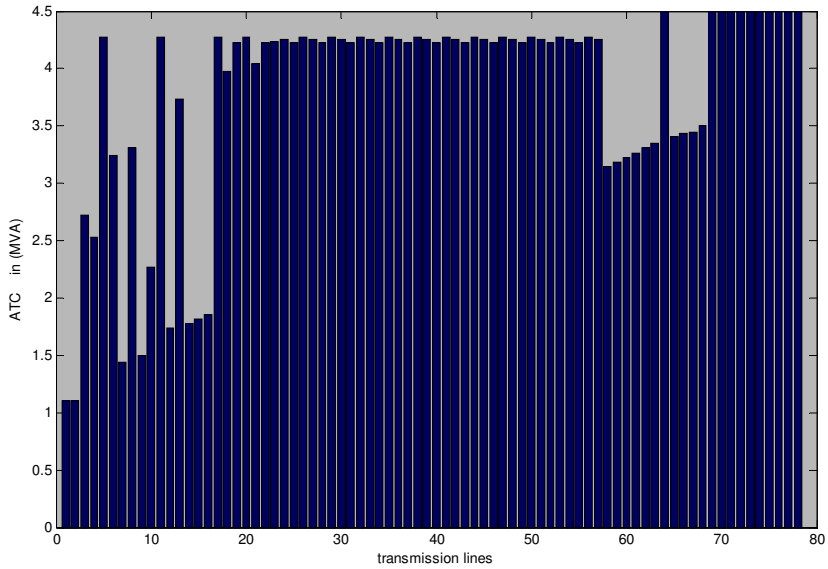

Fig. 6. ATC after removing line 4-5 & increasing load by 0.01 MW on bus 64

(B) Reconfiguration using Fuzzy adaptive Evolutionary Computing

From bus	To bus	kW loss	No. buses violating pu voltage limits	VDI
9	65	1.2061e+003	60	0.0570
10	52			
10	62			
29	43			

Table 1. Removing all tie-lines

Removing a tie-line and sectionalizing switches

1st set				2nd set				3rd set				4th set				5th set			
10	46	57	61	12	45	22	61	13	54	22	49	36	56	22	63	25	56	10	59
10	46	56	62	12	46	22	61	13	56	22	48	36	54	22	63	25	56	10	61
10	46	56	60	12	45	22	61	13	56	22	48	36	52	22	63	25	53	10	62
10	47	55	61	12	46	22	62	13	53	22	46	36	52	22	59	25	54	10	60
10	46	53	59	12	49	22	61	13	53	22	47	36	57	22	62	25	55	10	61

Table 2. Various combinations of lines taken from the system

1 st set	2 nd set	3 rd set	4 th set	5 th set
0.0612	0.0566	0.0613	0.9033	5.8420
0.0623	0.0572	0.0585	1.6155	0.9011
0.0631	0.0566	0.0585	0.9003	1.0099
0.0646	0.0569	0.9086	1.1593	1.0570
0.0662	0.0572	0.9034	0.9072	1.0439

Table 3. VDI corresponding to each set of combination

1 st set	2 nd set	3 rd set	4 th set	5 th set
1.1636	0.9718	0.9699	1.8091	1.7000
1.1580	0.9713	0.9717	1.7754	1.1775
1.1491	0.9718	0.9717	1.8497	1.6133
1.1486	0.9722	1.6280	1.6822	6.7298
1.1320	0.9723	1.7384	2.1014	1.8348

Table 4. KW loss incurred corresponding to each set of combination

1 st set	2 nd set	3 rd set	4 th set	5 th set
0.1162	0.0971	0.0969	0.1808	0.1699
0.1157	0.0970	0.0971	0.1774	0.1176
0.1148	0.0971	0.0971	0.1849	0.1612
0.1147	0.0971	0.1527	0.1681	0.6729
0.1131	0.0971	0.1737	0.2100	0.1834

Table 5. Members of fuzzy membership function (μ_L) for min kW loss

1 st set	2 nd set	3 rd set	4 th set	5 th set
0.8901	0.8901	0.8901	0.8816	0.8322
0.8900	0.8901	0.8901	0.8745	0.8817
0.890	0.8901	0.8901	0.8817	0.8806
0.8900	0.8901	0.8816	0.8791	0.8801
0.8900	0.8901	0.8816	0.8816	0.8802

Table 6. Members of fuzzy membership function (μ_V) for VDI

1 st set	2 nd set	3 rd set	4 th set	5 th set
0.1035	0.0864	0.0862	0.1594	0.1414
0.1030	0.0863	0.0864	0.1552	0.1037
0.1022	0.0864	0.0864	0.1630	0.1420
0.1021	0.0864	0.1434	0.1478	0.5922
0.1006	0.0864	0.1532	0.1852	0.1614

Table 7. Corresponding value of μ_r

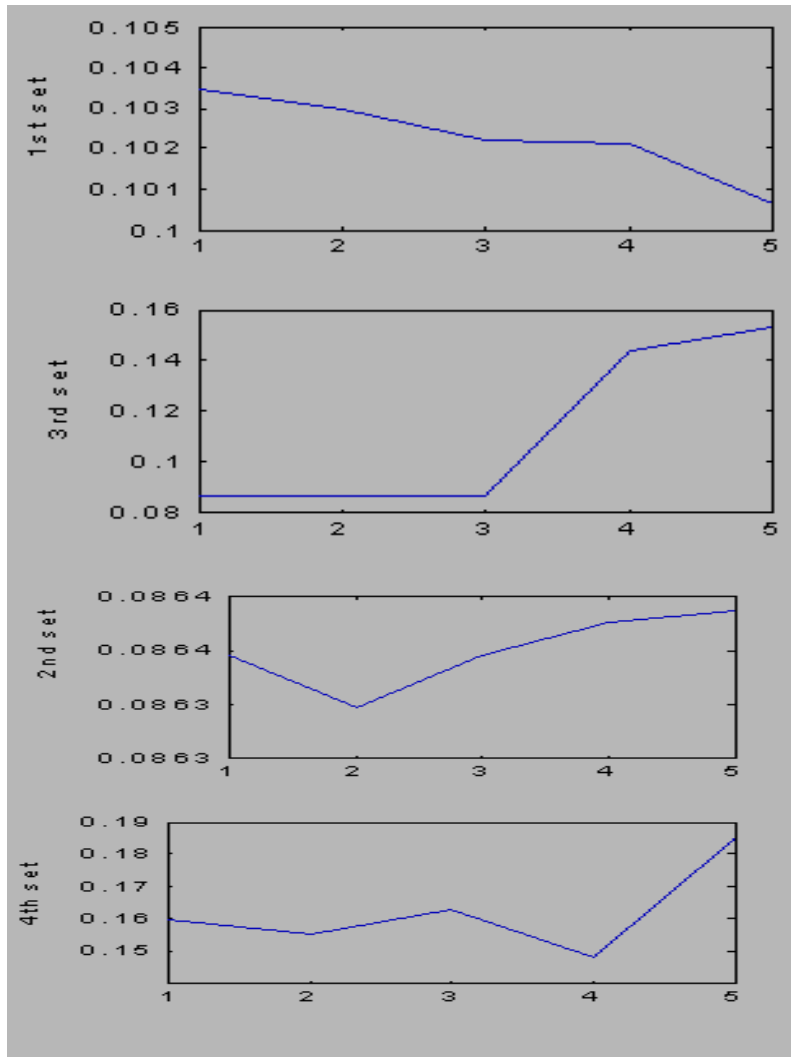

Fig. 6. Graphical representation of membership function of solution vectors

The Vellore 75 bus distribution network has been assessed by detecting the system abnormal operation based on S- difference criterion. It is observed that with increase in load on the system, the observed value of Re (SDC) is reducing with reducing pu voltage on the bus and at voltage collapse point, the criterion is approximately reducing to zero. Similarly linear ATC is reducing for each line with increase in load on buses in step. During the process of reconfiguration on the above test system, it is observed that the optimum performance is obtained by removing following lines [13 54 22 49], i.e.

[(10-62) (18-69) (42-43) (48-49)]

For a configuration having minimum loss is not necessarily to have minimum voltage deviation index, i.e., for a minimum loss configuration power quality may not necessarily be the best. The minimum limit of pu voltage, in a further lowered limit, there is a possibility of a solution having neither of index minimum, yet will give an optimum solution.

2.6 Power system restoration

2.6.1 Introduction

If any electric power supply interruption is caused by a fault, it is important to restore the power system as soon as possible to a target network configuration after the fault.

Various approaches have been presented to solve power system restoration problem. These techniques may vary in several major types: automated restoration, Heuristics system, mathematical programming, and computer aided restoration.

2.6.2 Multi-agent technique

Currently, multi-agent technique attracts more and more attention in many fields such as computer science and artificial intelligence. The multi-agent system is a decentralized network to solve problem. All the agents work together to obtain a global goal which may be beyond the capability of each individual agent.

Recently, several schemes also have been proposed to utilize multi-agent technique in power system. The implementation areas include stability control, transmission planning, market trading, and substation automation.

A multi-agent system is ideal for control of energy resources to achieve higher reliability, higher power quality, and more efficient (optimum) power generation and consumption. Because multi-agent systems process data locally and only transfer results to an integration center, computation time is largely reduced, and the network bandwidth is very much reduced compared to that of a central control. Multi-agent systems also allow scalability such as when new resources, loads, or interconnections are added to the system and extensibility such as performing new tasks or communicating a new set of data that becomes available.

2.6.3 Navy ship restoration problem

2.6.3.1 System objective and constraints for restoration

It is simple to realize the objective of the power system restoration is to restore the capacity as much as possible to the served loads.

$$\max \sum_{i \in uIS} L_i \quad (16)$$

Where L_i is the load at bus i , and US denotes the set of un-served loads.

And there are several typical constrains for this model:

- There is a limit for the available capacity for system restoration;
- The supply and demand power must be balanced;
- The system must keep radial configuration all the time. This constraint used is mandatory in the real power system operations.

2.6.3.2 Navy ship reference system

The Office of Naval Research (ONR) control challenge reference system is presented in the Figure 7. The complex system includes two finite inertia AC sources and buses, three zonal distribution zones feed by redundant DC power buses, and a variety of dynamic and nonlinear loads. Of course, an actual ship would have a more complex configuration.

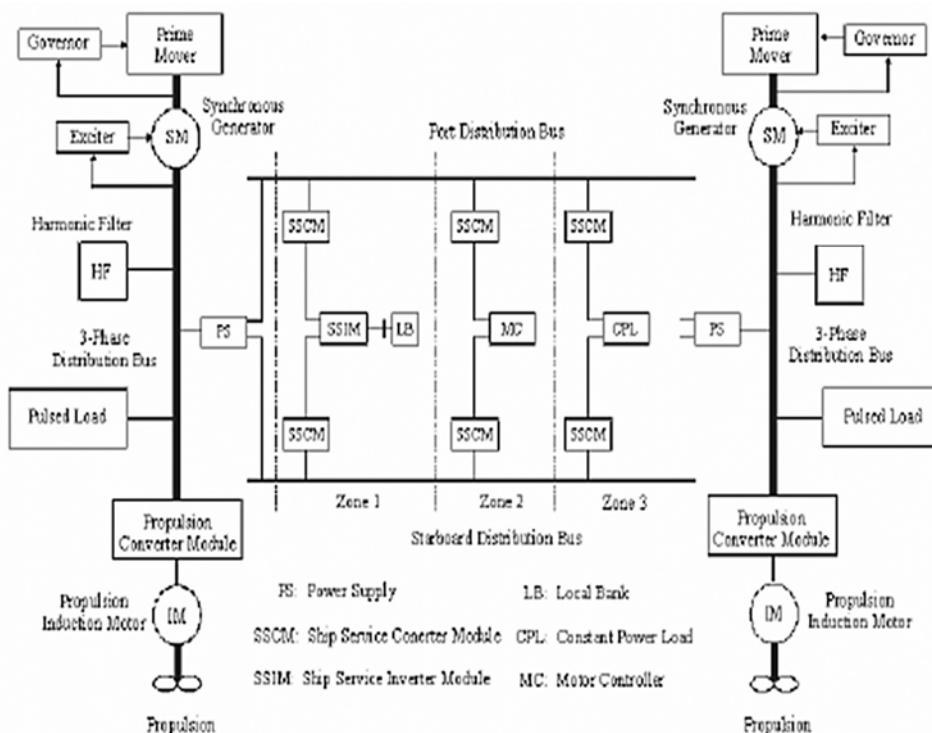

Fig. 7. ONR Control Challenge reference system

2.6.3.3 Multi-agent technique

An agent may be defined as entity with attributes considered useful in a particular domain. In this framework, an agent is an information processor that performs autonomous actions based on information.

A list of common agent attributes is shown below.

- **Autonomy:** goal-directedness, proactive and self-starting behavior.
- **Collaborative behavior:** the ability to work with other agents to achieve a common goal.

- “Knowledge-level” communication ability: the ability to communicate with other agents with language more resembling human-like “speech acts” than typical symbol-level program-to-program protocols.
- Reactivity: the ability to selectively sense and act.

Temporal continuity: persistence of identity and state over long periods of time.

A multi-agent system is a computational system in which several agents cooperate to achieve some task. The performance of multi-agent systems can be decided by the interactions among various agents. Agents cooperate so that they can achieve more than they would if they act individually.

A list of characteristics of Multi-Agent System is showing as follows:

- each agent has incomplete capabilities to solve a problem
- there is no global system control
- data is decentralized
- computation is asynchronous

Most of these characteristics can be seen in the following sections.

2.6.4 Multi-agent restoration frame work

Since the restoration problem is mainly concentrated on electric demand and supply component, the complex navy ship model has been simplified with only load and source component as in Figure 8. Also, switches and breakers are introduced for the study purpose. At each time, one load can be and only be connected to one power bus.

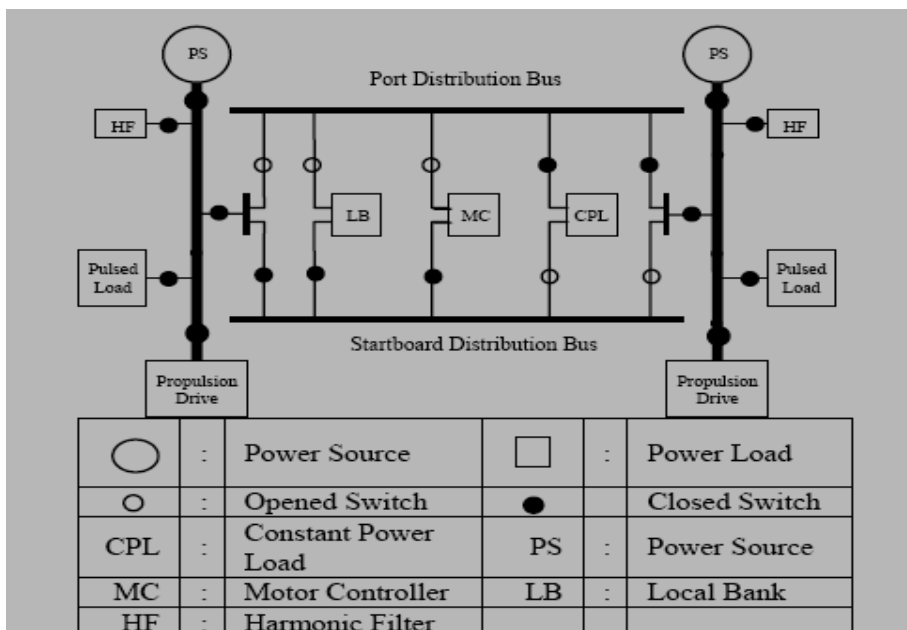

Fig. 8. Simplified reference system

The proposed multi-agent architecture for the ship system restoration use object-oriented design technique. To increase the efficiency of whole system, the types and total number of

agents need to be restricted. The proposed restoration system consists of three kinds of agents: a single Negotiating Agent (NA), a number of Load Agents (LA) and a number of Bus Agents (BA). Figure 9. shows the location of each LA and BA of the ship system. There are total 9 LAs and 4 BAs in the system.

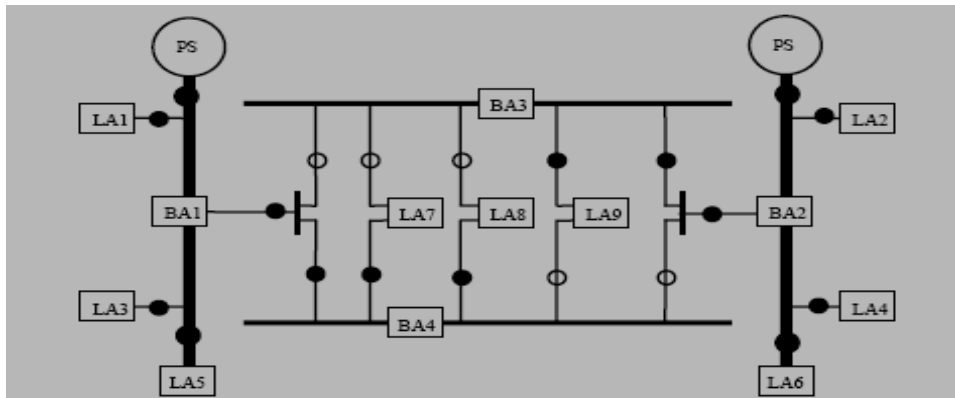

Fig. 9. Agents structure for ship system

Negotiating Agent, Bus Agents and Load Agents are in different levels. The whole system is divided as two subsystems, the communication sub system and operation subsystem.

Figure 10 and Figure 11 illustrate the current and communication paths in system. The dotted line in Figure 10 shows the potential current path.

LOAD FOR EACH LOAD AGENTS	
Agent Name	Load
LA1/ LA2	0 -5kW
LA3/ LA4	0 -2kW
LA5/ LA6	0 -37kW
LA7	0 -5kW
LA8	0 -5kW
LA9	0 -5kW

Table 8.

LA is designed to report load status and require for restoration. The active power of each load agent is shown in Table No 8.

The function of Negotiating Agent is to maintain the negotiation process of the whole system. NA receives the restoration request from un-served Load Agent, builds an un-served LA list, and instigates the restoration process by selecting corresponding BA.

BA is designed to decide a suboptimal target configuration after a fault occurs by interaction with other BAs. It is postulated that BA communicates only with its neighboring BAs. BA has the following simple negotiation strategies.

- If the amount of available power for restoration is insufficient, BA tries to restore the bus by negotiating with its neighboring BAs.

- BA always first selects the particular neighboring Bus Agent which connected to it already.
- If the BA succeeds the restoration, it tries to tell the neighboring agents.
- To keep system radial structure, one BA can only receive power from one other BA.

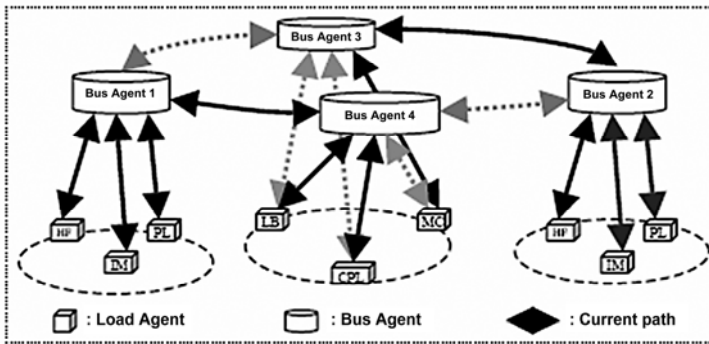

Fig. 10. Agents and current path structure for ship system

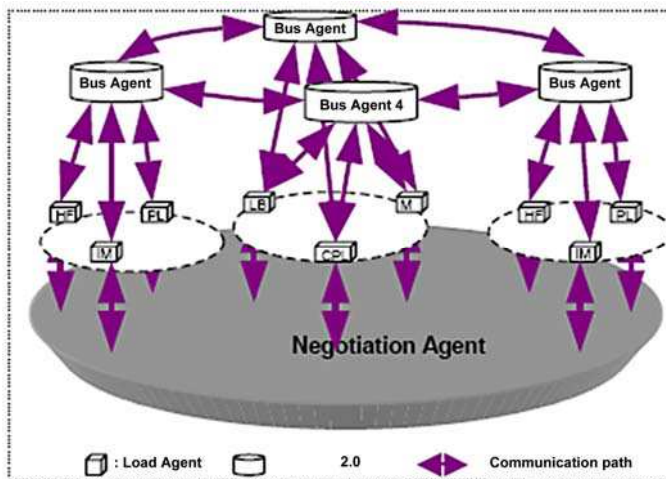

Fig. 11. Agents and communication paths structure for ship system

When there is a fault, after the fault isolation, the following procedures are proposed for ship system restoration.

- Step 1.** All the Load Agents report to the Negotiation Agent.
- Step 2.** Negotiation Agent creates the set of un-served Load Agents.
- Step 3.** Negotiation Agent send a “start” message to one and only one Load Agents to begin restoration based on pre-set priority list. When the number of LA in un-served LA list is zero, go to step 11.
- Step 4.** The selected Load Agent communicates with its connected Bus Agents.

- Step 5.** The Bus Agent tries to restore the Load Agent with its available capacity.
- Step 6.** If Bus Agent can finish the restoration by itself, go to step 9. Otherwise go to step 7.
- Step 7.** BA attempts to make negotiations with neighboring Bus Agents. If the restoration succeeds go to
- Step 10.** Other wise go to step 8
- Step 8.** The load Agent begins load shedding. And go to step 5
- Step 9.** The energized load agent sends a “restored” message to Negotiation Agent.
- Step 10.** The Negotiation Agent deletes the “restored” load agent from un-served load agent list. Then go to step 3.
- Step 11.** Terminate the restoration.

2.6.5 Case study

A number of simulations were performed for the proposed strategy. This section will show two typical test cases for total restoration and partial restoration respectively. We assume that the priority list for LAs is LA5>LA6 > LA8> LA9> LA3> LA4> LA7> LA1> LA2.

2.6.5.1 Case 1: Full restoration for fault on bus

We assume a fault on starboard distribution bus, under this particular fault, the shaded area shown in Figure 12 has lost power. Numbers near the LA shows the load, the numbers in the parentheses adjacent to the BAs represent the amount of power flow (left) and the available power capacity (right). The unit is kW.

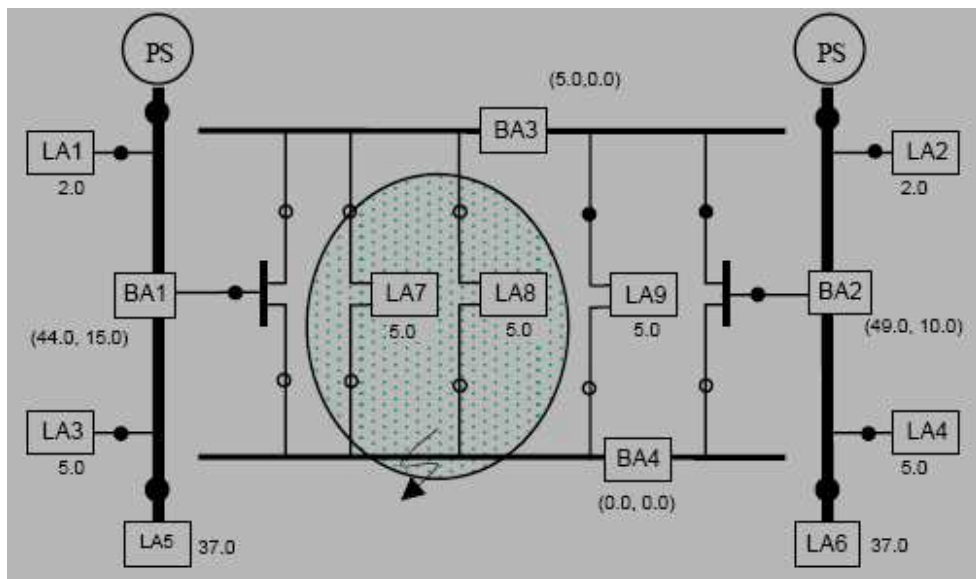

Fig. 12. Post fault network for case 1

In this case, the lines connected to starboard bus are tripped off because of the assumed fault and two loads (LA7, LA8) are to be resupplied by the agent system. For this particular case, BA1, BA2 both have power available for restoration.

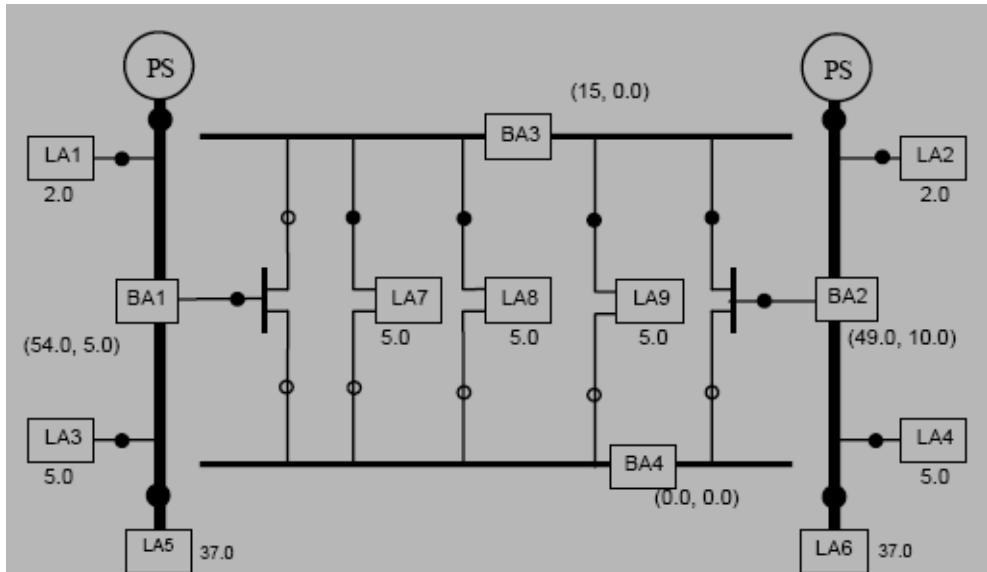

Fig. 13. Network after restoration for case 1

Based on the proposed procedure, negotiation rules, and preset LAs priority list, NA first creates the un-served set (LA7, LA8) and chooses LA8 as first LA to be restored. LA8 then sends restoration request to its Bus Agent BA4. Since the fault is still there, BA4 will send a refuse message to LA8. Thus LA8 tries to restore power from BA3. With 0 available capacities, BA3 first negotiates with its connected neighbor BA2 for more power capacity. Because available capacity of BA2 (10.0) is greater than the request capacity (5.0), BA2 will transfer 5.0 to LA8 through BA3. Once LA8 obtains sufficient power, it will send a message to NA. NA then deletes LA 8 from un-served set. Next, LA7 can also be restored similarly. The communication path is LA7→BA3→BA2. The new network is shown in Figure 13.

2.6.5.2 Case 2: Partial restoration for fault on generator

This case will show partial restoration where the amount of available power falls short of the sum of un-served loads. Now the fault happened in one synchronous generator, the system then lost one of its major power sources. Figure 14 shows the post fault network. Shaded area has lost power.

Like in case 1, the NA first creates un-served set (LA1, LA3, LA5, LA7, LA8). Based on preset priority list, LA5 is selected to be first resorted. Through negotiation path LA5→BA1→BA3→BA2, system can not restore LA5 for insufficient available capacity (10 < 37). Next, LA8 begins the restoration procedure by path LA8→BA4→BA2. After LA8 restoration, LA3 can be restored by path LA3→BA1→BA4→BA2. Later, LA1 and LA7 fail to obtain power.

The amount of available power is only 10. As the total amount of un-served loads is 54, the available power is insufficient to restore all the loads. Although three loads (LA1, LA5, LA7) are unfortunately disconnected as shown in the Figure 15, this is the optimal solution under these conditions.

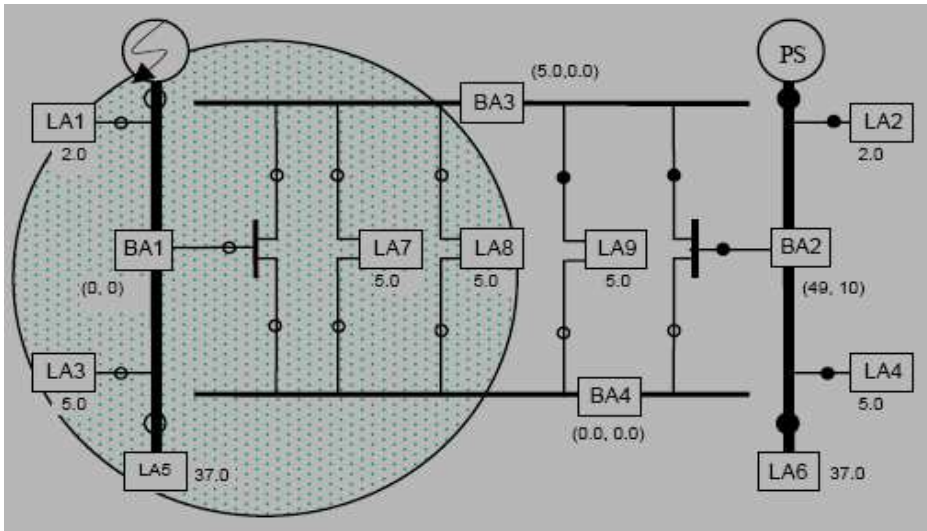

Fig. 14. Post fault network for case 2

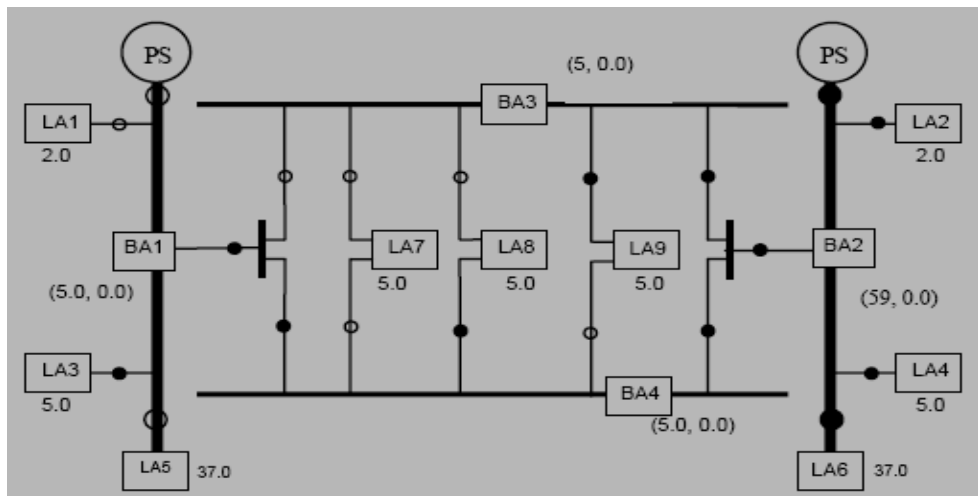
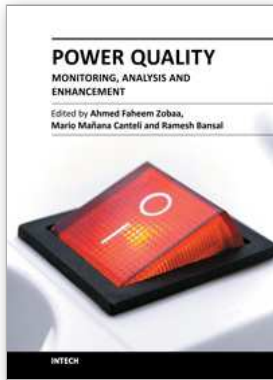

Fig. 15. Network after restoration for case 2

This section provides a multi-agent-based approach for navy ship system electric power restoration. The proposed system composed of three different agents. By negotiating among agents, without a control center, the system can perform restoration work by local information. Several test cases have been simulated for the presented method and proved to be successful. Since the whole approach is derived from a simplified ship system structure, the future work of this research will study more complex system structure. Agents control for synchronous generator, propulsion induction motor, and power inverter will be considered.

3. References

- Ashish Ahuja, Sanjoy Das, and Anil Pahwa, Fellow, IEEE, 2007, An AIS-ACO Hybrid Approach for Multi-Objective Distribution System Reconfiguration, *IEEE transactions on power systems*, vol. 22, no. 3, pp. 1101-1111.
- B. Venkatesh, Rakesh Ranjan, 2000, Optimal radial distribution system reconfiguration using fuzzy adaptation of evolutionary programming, *IEEE transactions on power systems*, vol. 15, no. 3.
- D.P. Kothari, I.J.Nagrath. 2007. Power System Engineering, Second Edition. Tata McGraw-Hill Publishing Company Limited. ISBN: 0070647917, 9780070647916, New Delhi.
- D.P. Kothari, I.J.Nagrath. 2008. Modern Power System Analysis, Third Edition, McGraw-Hill Publishing Company Limited. ISBN: 0070494894, 9780070494893, New York.
- D.P. Kothari, J.S.Dhillon. 2004. Power System Optimisation, Prentice Hall of India Private Limited. ISBN: 8120321979, 9788120321977, New Delhi.
- Dong Zhang, Zhengcai Fu, Liuchun Zhang, 2007, An improved TS algorithm for loss-minimum reconfiguration in large-scale distribution systems, *Electric Power Systems Research*, Volume 77.
- Dr. Paramasivam Venkatesh Ramachandran Gnanadass, Dr. Narayana Prasad Padhy, 2004. Available Transfer Capability Determination Using Power Transfer Distribution Factors, The Berkeley Electronic Press.
- Elgerd Olle I. 1983. *Electrical energy system theory- An introduction*, Second Edition. Tata McGraw-Hill Publishing Company Limited. ISBN-13: 978-0070992863, New Delhi.
- Ghiani E., Member IEEE, Mocchi S., Member, IEEE, and Pilo F., Member, IEEE, *Optimal Reconfiguration of Distribution Networks According to the Micro grid Paradigm*.
- Momoh James A., Feng Julian, 2009, A Multi-Agent-Based Restoration Approach for Navy Ship Power System, *6th International Conference on Power Systems Operation and Planning*, May 22-26, 2005, Cape Verde, pp.98-102, vol-1.
- Mukwanga W. Siti, Dan Valentin Nicolae, Adisa A. Jimoh, Member, IEEE, and Abhisek Ukil, 2007, *Reconfiguration and Load balancing in the LV and MV Distribution Networks for Optimal Performance IEEE transactions on power delivery*, vol. 22, no. 4, pp. 1128-1135.
- Nagata T., Sasaki H., and Yokoyama R., 1995, Power system restoration by joint usage of expert system and mathematical programming approach, *IEEE Transactions on Power Systems*, vol. 10, pp. 1473-1479.
- Rong-fu Sun, Yue Fan, Yong-hua Song, Senior Member, IEEE, Yuan-zhang Sun, Senior Member, IEEE, 2006, Development and Application of Software for ATC Calculation, *Electric Power Systems Research*, Volume 76.
- Salazar Harold, Student Member, Gallego Ramón, and Romero Rubén, Member, IEEE, 2006, Artificial Neural Networks and Clustering Techniques Applied in the Reconfiguration of Distribution Systems, *IEEE transactions on power delivery*, vol. 21, no. 3.
- Sivanagaraju, S., Visali, N., Sankar, V., Ramana, T, 2005, Enhancing voltage stability of radial distribution systems by network reconfiguration, *Electric Power Components and Systems* Vol.33 (5) pp. 539-550.
- Verbić Gregor, Panto's Milo's, Gubina Ferdinand, 2006. On voltage collapse and apparent-power losses, *Electric Power Systems Research*, Volume 76.
- Wu J. S., Liu C. C., Liou K. L., and Chu R. F., 1997, A petri net algorithm for scheduling of generic restoration actions, *IEEE Transactions on Power Systems*, vol. 12, pp. 69-76.



Power Quality Monitoring, Analysis and Enhancement

Edited by Dr. Ahmed Zobaa

ISBN 978-953-307-330-9

Hard cover, 364 pages

Publisher InTech

Published online 22, September, 2011

Published in print edition September, 2011

This book on power quality written by experts from industries and academics from various countries will be of great benefit to professionals, engineers and researchers. This book covers various aspects of power quality monitoring, analysis and power quality enhancement in transmission and distribution systems. Some of the key features of books are as follows: Wavelet and PCA to Power Quality Disturbance Classification applying a RBF Network; Power Quality Monitoring in a System with Distributed and Renewable Energy Sources; Signal Processing Application of Power Quality Monitoring; Pre-processing Tools and Intelligent Techniques for Power Quality Analysis; Single-Point Methods for Location of Distortion, Unbalance, Voltage Fluctuation and Dips Sources in a Power System; S-transform Based Novel Indices for Power Quality Disturbances; Load Balancing in a Three-Phase Network by Reactive Power Compensation; Compensation of Reactive Power and Sag Voltage using Superconducting Magnetic Energy Storage; Optimal Location and Control of Flexible Three Phase Shunt FACTS to Enhance Power Quality in Unbalanced Electrical Network; Performance of Modification of a Three Phase Dynamic Voltage Restorer (DVR) for Voltage Quality Improvement in Distribution System; Voltage Sag Mitigation by Network Reconfiguration; Intelligent Techniques for Power Quality Enhancement in Distribution Systems.

How to reference

In order to correctly reference this scholarly work, feel free to copy and paste the following:

S. Prabhakar Karthikeyan, K. Sathish Kumar, I. Jacob Raglend and D.P. Kothari (2011). Intelligent Techniques and Evolutionary Algorithms for Power Quality Enhancement in Electric Power Distribution Systems, Power Quality Monitoring, Analysis and Enhancement, Dr. Ahmed Zobaa (Ed.), ISBN: 978-953-307-330-9, InTech, Available from: <http://www.intechopen.com/books/power-quality-monitoring-analysis-and-enhancement/intelligent-techniques-and-evolutionary-algorithms-for-power-quality-enhancement-in-electric-power-d>

INTECH

open science | open minds

InTech Europe

University Campus STeP Ri
Slavka Krautzeka 83/A
51000 Rijeka, Croatia
Phone: +385 (51) 770 447

InTech China

Unit 405, Office Block, Hotel Equatorial Shanghai
No.65, Yan An Road (West), Shanghai, 200040, China
中国上海市延安西路65号上海国际贵都大饭店办公楼405单元
Phone: +86-21-62489820

Fax: +385 (51) 686 166
www.intechopen.com

Fax: +86-21-62489821

© 2011 The Author(s). Licensee IntechOpen. This chapter is distributed under the terms of the [Creative Commons Attribution-NonCommercial-ShareAlike-3.0 License](#), which permits use, distribution and reproduction for non-commercial purposes, provided the original is properly cited and derivative works building on this content are distributed under the same license.