

Mediation Role of Customer Advocacy in Customer Loyalty and Brand Equity Relationship – An Empirical Study in Context to In-store Brands

G. Shailesh* and D. Bhanusree Reddy

VIT Business School, VIT University, Vellore, Tamil Nadu – 632014, India;
shailesh.choudary@gmail.com, dbhanusreereddy@vit.ac.in

Abstract

Objectives: Brand equity and purchase decisions are considered as the key determinants of consumer behaviour. The objective of this study was to examine the role of loyal consumers in strengthening brand equity of In-store brands. **Statistical Analysis:** The method adapted to study the objectives is a cross sectional study. The study was carried out by self-administered questionnaire developed based on Likert scale. The survey was carried out at organised retail outlets in Bangalore city from 258 customers by following convenience sampling technique. PLS-SEM was used to analyse the data. Cronbach's Alpha was obtained to determine the reliability of the instrument. Further, convergent and discriminant validities were established to know the measures of relationship existing. Sobel's test was employed to test the mediation effect of customer advocacy between the relationship of customer loyalty and brand equity. **Findings:** From the results obtained it is observed that all AVE values obtained are greater than 0.5 i.e., Brand Equity (BE) is 0.7788, Brand Loyalty (BL) is 0.7863 and Customer Advocacy (CA) is 0.797, thus confirming the convergent validity of the constructs chosen. Further it is also observed that each construct chosen is distinct and different from the other constructs in the model. All the factor loadings of given construct are greater than corresponding cross loadings thus confirming the discriminant validity. The results of Sobel's test indicate that the impact of brand loyalty on brand equity is greater with the mediation effect of customer advocacy (Sobel test statistic t -values=3.627) than the direct effect of brand loyalty on brand equity (Sobel test statistic t -values=3.068). Thus we can clearly state that the relationship between Brand loyalty and Brand Equity can be best explained through Customer Advocacy. Both brand loyalty and customer advocacy have accounted for 60% of variance in brand equity, wherein brand loyalty has accounted for 45.3% of variance in customer advocacy. The findings of this study can be a reference for retailers to strategize their decisions with respect to in-store brands by laying more emphasis on customer advocacy. **Application/Improvements:** The outcomes reflect the positive influence of consumer advocacy on brand equity, by which the brand owners can strategize their moves towards enhancing brand equity by motivating advocacy of brands by the loyal customers to prospects, thus reducing excessive promotional costs by the brand owners.

Keywords: Brand Equity, Customer Advocacy, Customer Loyalty, In-store Brands, Mediation

1. Introduction

Managing customer relationship is considered to be the key business success factor which is considered to be the most essential function of any organisation to survive in

the long-run. Many organisations have observed drastic growth in its market share and profits by emphasising on relationship management as one of their core functions. Relationship marketing is one of the most researched topics in marketing. The act of formation, retaining

*Author for correspondence

and enhancing the customer relationships in business is referred to as Relationship Marketing¹. Creating an edge over competitive advantage in terms of quality products and services has become an inherent goal of all the organisations commonly. In-order to differentiate themselves from competitors, relationship marketing is considered to be a strategic move. Changing lifestyles and increasing economic status have resulted in empowering the customers in today's market scenario and thus leading to change in consumer behaviour. In the process of retention of existing customers; augmenting the association, consumer sensitivity to price changes and customer advocacy are alleged to be the key indicators of buyer behaviour². The loyal customers get converted into customer advocates in order to attract prospective customers on behalf of the organisations³. As a result of the new dimensions identified by the researches in measuring brand equity, the purpose of this study is to test the variance in association between customer loyalty and brand equity with the mediation effect of customer advocacy.

1.1 Brand Equity

The entry of MNC's and emergence of business practices with sophisticated technologies has led to cut throat competition for the marketers in stabilising their brand performance. The value customers' associate with a brand is termed as Brand Equity⁴. The changing consumer preferences and purchase intentions are determined by brand equity. The higher brand equity levels are the antecedents of purchase intentions and higher consumer preferences⁵. Brand value perception is a critical factor that leads to difference in views and opinions about different brands in the minds of customers. The brand value perception that has developed in consumers' mind results in changing consumer views with regard to performance of the product when matched with competitors' offerings⁶. Consumers reflect their preferences based on brand names. Customer-based brand equity is discussed to be probing the response of the consumer by a brand name perspective⁷. The customers' learning, feeling and observation about the brand based on their experiences over time reflect the value of the brand⁸. Consumers' associations with the brands play a vital role in determining brand equity. Consumers' perceptions and associations with the brand name results in enhancing brand equity through value creation to a product⁹. The brand value and strength both together embraces brand equity. All those who are associated directly or indirectly

contribute to the strength of the brand. The Brand strength built by all the participants and the establishment associates connected with the brand determines brand's sustainability¹⁰. It is also stated that Brand Value is determined by brand asset which is a composition of brand image, brand reputation, perceived quality and customer acceptance¹¹. Further it was stated that the additional assets identified by them that are associated to the brand in the form of trade mark, patents and associations in the supply channel¹². A customer will give away the buying choice of one brand to buy some other brand. It was claimed that brand equity is the variance among the choice possibility of a certain brand and the core brand³. Researchers and practitioners have narrowed down the determinants of brand equity. It is stated that Awareness, Perceived quality, Associations, and Loyalty are believed to be the factors of Brand equity¹³. The relationship between perceived risk and brand equity is well established. It was claimed that in the course of the new product adoption, brand equity reduces the perceived risk even in situations controlled by functional buying decisions¹⁴. This study empirically investigates how the loyal customers would contribute in enhancing brand equity of In-store brands as customer advocates. Building brand equity in the current market scenario is mostly based on customer advocacy made by loyal customers.

1.2 Customer Loyalty

Each and every business organisation would aim at establishing a sustainable market share. To attain a sustainable market share it is very much essential to attract potential customers, meet their expectations and also retain them by giving a differential experience on a continuous basis. It was propagated the concept of consumer loyalty where he explained customer loyalty as prejudiced, behavioural response, depicted in due course, with regards to several substitute brands which is a role of psychological process¹⁵. Consumer loyalty establishes the brand value of an organisation⁴. Consumer loyalty gains returns to an establishment. It was claimed that both behavioural as well as attitudinal components must be embodied as customer loyalty¹⁶.

Today's brand owners and retailers lay more emphasis on existing customers. Consumer determination results in consumer advocacy¹⁷. Loyal customers are considered to be leading organisations to generate more revenues. It was claimed that the loyal customers spend more when compared to non-loyal customers and also represent the

brand as advisers by propagating positive word of mouth, because of which they are believed to be the firm's most valuable customer group¹⁸. It was also stated that brand loyalty reflects consumer preference while choosing the same brand as well as restrain from moving over to competitors' brands¹⁹. Brand loyalty is believed to be the primary factor of brand equity as it reduces expenditures and assists in implementing tasks with in an organisation²⁰. The association between a customer and brand is consumer loyalty⁸. Brand loyalty is considered to be the principle brand equity determinant²¹. The Brand loyalty lowers scepticism and also save expenses of developing relationships with other brand²². It was claimed that emerging brands encompassing strong brand equity is essential for the sustainability and advancement in running business as loyalty expressed over future intensions of buying contributes to the business outcome of the organization²³. Subsequently the retailers should implement necessary measures that can stimulate the loyal customers to endorse the brands to potential shoppers consequently augmenting brand equity by recognizing the significance of loyal customers.

1.3 Customer Advocacy

The buying behaviour of potential customers is majorly influenced by recommendations of customer advocates in the present scenario. Prospective buyers consider information and facts from associates or perhaps strangers as less prejudiced and trustworthy compared to the information from economic entity. Customer advocacy is the intention of the consumer to offer positive referrals to other consumers by backing the product or service seller²⁴. In case the encounters are undesirable, negative word of mouth would certainly direct potential prospects to refrain from a brand or a retailer. It is stated that customer satisfaction has a positive effect on customers' willingness to recommend which is a loyalty outcome²⁵. While customers deliver positive advice on products, services or brands to other people they are simply playing the role of advisers in support of that product²⁶. Comparison of brands, products or services has become an inherent element of consumer buying process due to the facility made available by the brand owners and the retailers^{27,28}.

The consequence of which the institutions are countering by developing advocacy oriented practices and techniques^{29,30}. Customer advocates recommend their retailer to others buy more from that

retailer as new products become available and stay with that primary retailer even when competitors' offerings are new. Trust and loyalty can be earned by assisting consumers to find and opt for the best choice in a given market³¹. Those customers having received differentiated benefits would have a higher degree of satisfaction. Eventually, these customers will create positive viral marketing effect³². This paper presents the research findings of new developments in brand equity determinants with the inclusion of customer advocacy as one of the determinant. It is stated that customer advocacy is sometimes termed as positive word-of-mouth³⁰.

1.4 Customer Loyalty and Brand Equity

Consumer loyalty is one among the principal brand equity antecedent. A potential loyal consumer source can result in exceptional considerable difference in brand equity⁴. It was confirmed that the strengthening of brand equity is based on superior confidence that customers maintain when it comes to a brand as compared to its business rival¹⁰. The study outlined brand equity as "brand identification, brand associations, brand image, perceived quality and consumer contentment"⁴. Brand loyalty is a significant and primary determinant of a brand's equity. Strong brand equity optimizes beneficial thinking of service or a product as well as enhances customer loyalty concerning the brand over-all³¹. Consumer loyalty is definitely the most effective path contributing to brand equity as well as presents positive and steer role in influencing brand equity³³. The brand loyalty of the consumers is the most essential determinant of a brand's equity³⁴. While the undoubtedly emphasize that consumer loyalty is an important determining factor of brand equity, it will be significantly essential for the own brand retailers to place attention on the components that transform prospective consumer to a loyal consumer with a purpose to strengthen the brand equity of store owned brands.

H1: Customer Loyalty has Significant Impact upon Brand Equity

1.5 Consumer Loyalty and Consumer Advocacy

Consumer Loyalty and Consumer Advocacy are considered to be having a very powerful relationship with each other. Potential consumers differentiate information

from acquaintances or maybe strangers as much more unprejudiced and dependable as compared to the ones from that of economic entity. Customer Advocacy is considered to be significant outcome of consumer determination². Several researchers have reviewed the association amongst advocacy loyalty and affective commitment and also their effect on repeat purchase loyalty³⁵⁻³⁷. They have claimed that there is consistently high significance and positive impact among advocacy loyalty, affective commitment, and repeat buying loyalty. Affectively dedicated customers of a brand are more inexpensive to retain. They are also less susceptible to loss due to more competitive actions and may also possibly experience service failures. It was claimed that the loyal customers would be willing to pay higher prices and also desire to recommend the brand to others through brand advocacy³⁸. It is stated that advocacy can be comprehended as a loyalty outcome^{39,40}. Hence the well versed loyal consumers of a brand are likely to endorse the brand to their peers. The concept of consumer advocacy is very significant as it diffuses sense and essence of consumer's brand commitment and also enhancing the brand equity.

H2: Consumer Loyalty has Significant Impact upon Customer Advocacy

1.6 Customer Advocacy and Brand Equity

Advocacy is simply more desirable than various other promotional tools in the market place condition. Advisers who happen to be high influencers as well as represent opinion frontrunners are regarded as playing a significant role in recommending brands to prospective purchasers. Advocacy is been given very much importance as it enhances market share by steering product sales as well as accelerate consumer relationships which over-all results in augmenting brand equity. It is stated that the Advocacy approach encompasses a trusted advisor position as it strives to assist consumers make best purchase choices in order to optimise the outcome from the service or a product⁴¹. It is established that it is cost effective to manage enduring consumer associations as opposed to approach of appealing to new consumers¹⁸. In the process of determining enhancement of relationship; consumer retaining, price sensitivity along with advocacy are observed to be the outcomes of consumer behaviour^{17,37,42}. It is stated that establishments over time transform loyal consumers into advisers who therefore entice new prospective consumer groups behalf of the firms⁴³. Existing customers recom-

mend product or service provider to their peer groups if their expectations are met. Advocacy is the readiness of the consumer to share strong thoughts to other consumers through extending their support to product or service provider³⁸. Consequently, it is going to be an accelerating action if the retailers systematise the procedure as well as come up with approaches promoting consumer advocacy with the intention to enhance brand equity.

H3: Customer Advocacy has a Considerable Effect upon Brand Equity

H4: Customer Advocacy will mediate the Effect of Customer Loyalty on Brand equity

2. Proposed Work

Figure 1 describes the framework of the relationship between the variables.

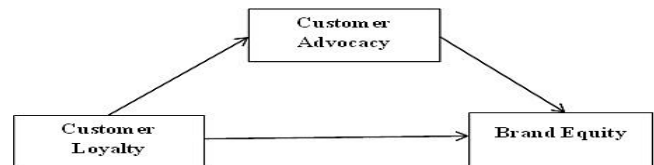

Figure 1. Model developed for the study.

2.1 Objectives

1. To examine the role of loyal consumers in strengthening brand equity of In-store brands
2. To determine the role of consumer advocacy in enhancing the association between Brand Equity and consumer loyalty

2.2 Research Methodology

- i. Descriptive study with cross sectional design is employed to carry out this study. A self-administered questionnaire consisting of 12 items as shown in Table 1, that measure the determinants of brand equity was used as instrument of data collection. The items were evaluated on a Likert scale starting from 1 representing “strongly disagree” to 5 signifying “strongly agree”. The evaluation instruments for several constructs in the framework were derived from existing scales or studies in the literature.
- ii. Sampling Frame

Table 1. Variable Measuring Items

Sl No.	Variables	Measuring Items	Adopted
IV	Brand Loyalty	Repeat Purchase Top of Mind Brand switching Favorable attitude	Yoo et al.,(2000) Pappu et al., (2005)
Me	Customer Advocacy	Reference Experience sharing Recommendation Positive opinion	Kim and Gwinner (2010) Fullerton (2011)
DV	Brand Equity	Sense Feature based preference Availability based preference Smarter purchase	Yoo et al.,(2000)

The survey was conducted from January 2016 to April 2016. Sample Population is chosen from the Customers of Organized retail outlets in Bangalore city – Future Group Big Bazaar, Aditya Birla- More, Reliance Fresh, SPAR, and Star Bazaar. The data was collected from 258 customers of the above mentioned retail outlets by following convenience sampling technique. After data collection PLS-SEM was used to analyse the collected data and derive the results.

2.3 Analysis and Results

In order to test the hypothesized causal relationship Structural Equation Modeling (SEM) was employed by using Smart PLS.

2.3.1 Reliability Analysis

Cronbach's Alpha technique was computed in order to determine the internal consistency of the scales. As presented in Table 2 the Cronbach's α value obtained for each construct was greater than 0.9 (the suggested threshold value is 0.7). The reliability analysis of the chosen constructs such as brand loyalty, customer advocacy and brand equity has resulted in high reliability as the values obtained are greater than 0.7, which is a positive indicator for the proposed model. Table 1 shows the reliability and validity statistics.

Table 2. Reliability and Validity Statistics

Variables	AVE	Composite Reliability	R Square	Cronbach's Alpha	Communality
BE	0.7788	0.9337	0.5997	0.9052	0.7788
BL	0.7863	0.9363	0	0.9092	0.7863
CA	0.797	0.94	0.453	0.915	0.797

2.3.2 Validity Analysis

For this study we have employed two validity tools to check the validity of the model namely convergent validity and discriminant validity.

2.3.3 Convergent Validity

From the results obtained and presented in Table 3, it is observed that convergent validity of the constructs chosen for the study is meeting the requirement of criterion standard i.e., greater than 0.5⁴⁴. All AVE values obtained are greater than 0.5 i.e., Brand Equity (BE) is 0.7788, Brand Loyalty (BL) is 0.7863 and Customer Advocacy (CA) is 0.797, thus confirming the convergent validity of the constructs chosen.

Table 3. Factor loadings Statistics

Items/Variables	Brand Equity	Brand Loyalty	Customer Advocacy
Brand Equity 1	0.8579	0.5586	0.5784
Brand Equity 2	0.9224	0.6436	0.6762
Brand Equity 3	0.8835	0.666	0.659
Brand Equity 4	0.8648	0.5872	0.6137
Brand Loyalty 1	0.643	0.8584	0.6103
Brand Loyalty 2	0.6427	0.9148	0.6
Brand Loyalty 3	0.6277	0.9072	0.63
Brand Loyalty 4	0.5548	0.8652	0.5407
Customer Advocacy 1	0.6713	0.6593	0.9351
Customer Advocacy 2	0.5875	0.507	0.8668
Customer Advocacy 3	0.6877	0.673	0.9117
Customer Advocacy 4	0.6077	0.5435	0.8549

2.3.4 Discriminant Validity

From the results obtained it is observed that each construct chosen is distinct and different from the

other constructs in the model, thus meeting the established criterion⁴⁵. As shown in Table 2, all the factor loadings of given construct are greater than corresponding cross loadings thus confirming the discriminant validity.

2.3.5 Mediation Effect Test Analysis

Figure 2 represents the mediation effect test results. Sobel's test was employed wherein the indirect effect is greater than direct effect on the dependent variable i.e., the impact of brand loyalty on brand equity is greater with the mediation effect of customer advocacy [Sobel test statistic t -values=3.627 (>1.96)] than the direct effect of brand loyalty on brand equity (Sobel test statistic t -values=3.068). Thus we can clearly state that the relationship between Brand Loyalty (BL) and Brand Equity (BEQ) can be best explained through Customer advocacy. Figure 3 represents the amount of variance the variables would be accounting on brand equity. Both brand loyalty and customer advocacy have accounted for 60% of variance in brand equity, wherein brand loyalty has accounted for 45.3% of variance in customer advocacy.

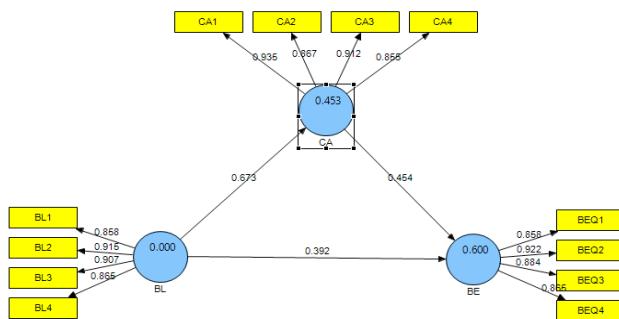

Figure 2. Path Co-efficients and R² values.

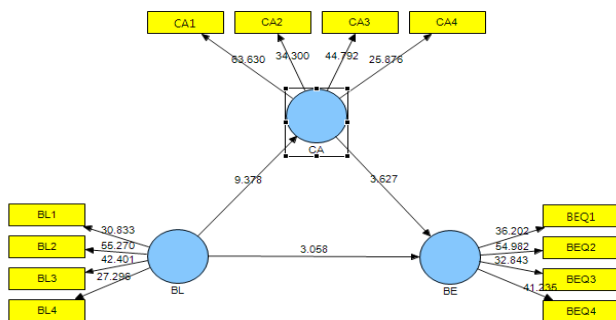

Figure 3. t -values.

3. Discussion and Conclusion

The present study gives an insight to how advocacy mediates the relationship between Customer Loyalty and Brand Equity in a retail context. Although the need to proactively concentrate on customers' advocacy continues to be significantly acknowledged within marketing, its actual effect on brand equity is not well confirmed. Comprehending this relationship is crucial considering that loyalty is the principal antecedent of brand equity. Further the relationship may be better described with the mediation effect of customer advocacy. Outcomes of the present study recommend that it must be the blended influence of consumer loyalty as well as customer advocacy that is crucial in figuring out the potency and value of brand equity.

The outcomes of this research will contribute to the understanding of current trend in consumer buying process. First, the findings clearly present the strong relationship existing between the proposed variables in context to In-store brands. Loyal customers are always believed to be the root cause of brand existence and brand building. Therefore, it is very much essential that the retailers cater to the evolving needs and preferences of loyal customers. This research reveals that the role of customer loyalty is crucial in enhancing customer advocacy. The next contribution of the study reveals the exploration of customer advocacy as a mediator between consumer loyalty and brand equity. From the literatures it can be recognized that a customer's purpose to discuss with their acquaintances, family members, and other potential prospects about their experiences with an organization or merchandise is considered to be an exhibition of loyalty towards the merchandise or organization. However, the results of this study indicate the indirect effect is greater than the direct effect i.e., the effect of customer loyalty on brand equity is greater with the mediation effect of customer advocacy than the direct effect of customer loyalty on brand equity. Therefore, a strong recommendation can be made to the retailers to lay more emphasis on creating larger number of advocates by employing measures that would enhance loyalty and thus resulting in advocacy, as ultimately advocacy could be described as the outcome of loyalty. Enhancing loyalty is possible if the retailers provide differentiated, consistent and valuable experience to the customers.

Attaining a strong position in the market by maintaining high brand equity is the objective of any

strategic move by the organizations. In the present study, the outcomes clearly present the relationship levels among customer loyalty, consumer advocacy and brand equity. The influence of consumer advocacy on brand equity is majorly observed by which the brand owners can focus more upon strategizing their moves towards enhancing brand equity by giving importance to retaining and motivating advocacy of brands by the loyal customers to prospects, thus reducing the need for excessive promotions by the brand owners.

4. References

- Berry L, Parasuraman. *Marketing Services: Competing Through Quality*. New York: Free Press; 1991.
- Price, Linda, Arnould. *Commercial Friendships: Service Provider-Client Relationships in Context*. *Journal of Marketing*. 1999; 63 (4): 38–56.
- Srinivasan, Park C, Su S, Chang DR. An Approach to the measurement, analysis, and prediction of Brand Equity and its sources. *Management Science*. 2005; 51 (9): 1433–48.
- Aaker DA. *Managing Brand Equity*. New York: Free Press; 1991.
- Cobb-Walgreen J, Ruble CA, Donthu N. Brand equity, brand preference, and purchase intention. *Journal of Advertising*. 1995;24(3): 25–40.
- Keller. *Strategic Brand Management: Building, Measuring and Managing Brand Equity*, Upper Saddle River. NJ: Prentice Hall; 1998.
- Shocker AD, Srivastava RK, Reukert RW. Challenges and opportunities facing brand management: An introduction to special issue. *Journal of Marketing Research*. 1994; 31(2): 149–158.
- Keller. L. *Strategic Brand Management: Building, Measuring and Managing Brand Equity* (2nd Ed). NJ: Prentice-Hall; Englewood Cliffs, 2003. 1–24.
- Winters C. Brand equity measures: Some recent advances. *Marketing Research*. 1991; 3(4): 70–3.
- Lassar W, Mittal B, Sharma. Measuring customer- based brand equity. *Journal of Consumer Marketing*. 1995; 12(4):11–9.
- Kapferer. Why are we seduced by luxury brands? *Journal of Brand Management*. 1998, 6(1): 44–9.
- Pappu R, Quester PG, Cooksey RW. Consumer based brand equity: Improving the measurement - empirical evidence. *Journal of Product and Brand Management*. 2005; 14 (2-3):142–154
- Kim JH, Hyun YJ. A model to investigate the influence of marketing-mix efforts and corporate image on brand equity in the IT software sector. *Industrial Marketing Management*. April 2011; 40(3): 424–38.
- Stavros P, Kalafatis, Natalia Remizova, Debra Riley, Jaywant Singh. The differential impact of brand equity on B2B cobranding. *Journal of Business and Industrial Marketing*. 2012; 27 (8):623–34.
- Jacoby, Jan B, Robert W Chestnut. *Brand Loyalty*. New York: John Wiley; 1978.
- Dick, Alan S, Kunal Basu. Customer Loyalty: Toward an integrated conceptual framework. *Journal of the Academy Marketing Science*. 1994; 22(2): 99–113
- Morgan, Robert M, Shelby D Hunt. The Commitment-Trust Theory of Relationship Marketing. *Journal of Marketing*. Jul 1994; 58(3):20–38.
- Zeithaml VA, Berry LL, Parasuraman A. The behavioural consequences of service quality. *Journal of Marketing*. 1996;60(2):31–46.
- Yoo B, Donthu N, and Lee S. An examination of selected marketing mix elements and brand equity. *Journal of the Academy of Marketing Science*. 2000; 28 (2): 195–211.
- Rundle Thiele S, Bennett, R.A brand for all seasons? A discussion of brand loyalty approaches and their applicability for different markets. *Journal of Product and Brand Management*. 2001; 10(1): 25–37.
- Tong X, Hawley JM. Measuring customer-based Brand Equity: Empirical evidence from the sportswear market in China. *Journal of Product and Brand Management*. 2009; 18(4): 262–71.
- Erenkol AD, Duygun A. Customers' perceived Brand Equity and a research on the customers of Bellona which is a Turkish furniture brand. *The Journal of American Academy of Business*. 2010; 16(1):93–109.
- Dlacic J, Kezman E. Exploring relationship between brand equity and customer loyalty on Pharmaceutical market. *Journal of Economics and Business Review*. 2014; 16(2):121–31.
- Hill S, Provost F, Volinsky C. Network based marketing: Identifying likely adopters via consumer networks. *Statistical Sciences*. 2006; 21 (2): 256–76.
- Jana A, Chandra B. Mediating role of customer satisfaction in the mid-market hotels: An empirical analysis. *Indian Journal of Science and Technology*. Jan 2016; 9(1):12–13.
- White SS, Schneider B. Climbing the commitment ladder: The role of expectations disconfirmation on customers' behavioural intentions. *Journal of Service Research*. 2000; 2 (3): 240–53.
- Pitt LF, Berthon PR, Watson RT, Zinkhan GM. The internet and the birth of real consumer power. *Business Horizons*. 2002; 45(4):7–14.
- Wind J, Rangaswamy A. Customerization: The next revolution in mass customization. *Journal of Interactive Marketing*. 2001; 15(1):13–32.

29. Sawhney M, Kotler P. Marketing in the Age of Information Democracy. Kellogg on Marketing. In D Iacobucci (Ed). New York: John Wiley Ltd; 2001.pp. 386–408.
30. Urban G. The emerging era of customer advocacy. MIT Sloan Management Review. 2004; 45(2):77–82.
31. Lawer C, Knox S. Customer advocacy and brand development. Journal of Product and Brand Management. 2006; 15 (2):121–29.
32. Ki-Heung Yim, Jin-Hee Kwon. A Study on the impact of musical reputation on consumer satisfaction and word-of-mouth intention with on-line price discount as a moderating variable. Indian Journal of Science and Technology. Apr 2015; 8(S8):167–72.
33. Keller K L. Branding and brand equity. Cambridge. MA: Marketing Science Institute, 2002.
34. Atilgan E, Aksoy S, Akinci S. Determinants of the brand equity: a verification approach in the beverage industry in Turkey. Marketing Intelligence and Planning. 2005; 23 (3): 237–48.
35. Boo S, Busser J, Baloglu S. A model of customer based brand equity and its application to multiple destinations. Tourism Management. 2009; 30(2): 219–31.
36. Gruen, Thomas, John Summers, Frank Acito. Relationship marketing activities, commitment and membership behaviours in professional associations. Journal of Marketing. 2000; 64 (3): 34–49.
37. Bansal H, Irving G, Taylor S. A three component model of customer commitment to service providers. Journal of the Academy of Marketing Science. 2004; 32(3): 234–50.
38. Harrison Walker J. The measurement of word-of-mouth communication and an investigation of service quality and customer commitment as potential antecedents. Journal of Service Research. 2001; 4(1): 60–75
39. Grisaffe DB, HP Nguyen. Antecedents of emotional attachment to brands. Journal of Business Research. 2011; 64(10):1052–59.
40. Susanta, Alhabsji T, Idrus, MS Nimran U. The effect of relationship quality on Customer Advocacy: The mediating role of loyalty. Journal of Business and Management. 2013; 12(4): 41–52.
41. Sheth, Jagdish N, Rajendra S Sisodia, Sharma A. The antecedents and consequences of customer-centric marketing. Academy of Marketing Science. 2000; 28 (1):55–66.
42. Fullerton G. Creating advocates: the roles of satisfaction, trust and commitment. Journal of Retailing and Consumer Services. 2011; 18(1): 92–100.
43. Shaun Smith, Joe Wheeler. Managing the Customer Experience. Financial Times: Prentice Hall; 2002.
44. Fornell C, Larcker D.F. Evaluating structural equation models with unobservable variables and measurement error. Journal of Marketing Research. 1981; 18 (1): 39-50.
45. Carmines, Edward G, and Richard A Zeller. Reliability and Validity Assessment. Newbury Park, CA: Sage Publications; 1979.