

PAPER • OPEN ACCESS

Numerical study for identification of influence of energy absorption and frontal crush for vehicle crashworthiness

To cite this article: Shwetabh Suman *et al* 2017 *IOP Conf. Ser.: Mater. Sci. Eng.* **263** 062075

View the [article online](#) for updates and enhancements.

Related content

- [Numerical Study on Microwave Scattering by Various Plasma Objects](#)
Wang Guibin, Zhang Lin, He Feng et al.
- [Crush analysis of the foam-filled bitubal circular tube under oblique impact](#)
F Djamaluddin, S Abdullah, A K Arrifin et al.
- [Study and Optimization of Helicopter Subfloor Energy Absorption Structure with Foldcore Sandwich Structures](#)
Zhou HuaZhi and Wang ZhiJin

Numerical study for identification of influence of energy absorption and frontal crush for vehicle crashworthiness

Shwetabh Suman, Haard Shah, Vaibhav Susarla and K Ravi

School of Mechanical Engineering, VIT University, Vellore-632014, Tamil Nadu, India

E-mail: ravi.krishnaiah@vit.ac.in

Abstract: According to the statistics it has been seen that everyday nearly 400 people are killed due to road accidents. Due to this it has become an important concern to concentrate on the safety of the passengers which can be done by improving the crashworthiness of the vehicle. During the impact, a large amount of energy is released which if not absorbed, will be transmitted to the passenger compartment. For the safety of the passenger this energy has to be absorbed. Front rail is one of the main energy absorbing components in the vehicle front structure. When it comes to the structure and material of the part or component of the vehicle that is to be designed for crash, it is done based on three parameters: Specific Energy of Absorption, Mass of the front rail and maximum crush force. In this work, we are considering different internal geometries with different materials to increase the energy absorbing capacity of the front rail. Based on the extensive analysis carried aluminium seems to be the opt material for frontal crash.

1. Introduction

Crashworthiness is the ability of a vehicle to absorb energy for protecting passengers during an impact. This becomes the foremost important criterion to design. Statistics show that around 40% of the fatalities of car occupants occur in frontal impact [1]. According to government regulations and demand from the customer side, it becomes the first criteria while designing. The amount of energy dissipated is dependent on collapse mode. Axial collapse dissipates more energy than bending. It is very challenging for the engineers to design a front rail which is very difficult to crush axially. The energy absorption ability of the vehicle frame will be affected by crash directions. A stiff structure provides protection against deformation but it results in higher rate of deformation in the passenger occupant [2]. The end of front structure should be stiff enough to maintain passenger survival space [3]. A good crashworthy structure should be stiff in sensitive areas like fuel tank and passenger compartment, also soft to absorb collision energy. At the time of collision, the vehicle's speed decreases from its travelling speed to zero within milliseconds. One way to minimize the injury due to sudden change in velocity is to increase the impact time, due to this less force will be transferred in passenger cell. The oblique loading effect is considered in the front rail topology design process [4].

The energy absorbing ability and to limit the deformation behavior the following methods can be used:

- The welding position and cross section of the frontal rails.
- The thickness of the rails.
- The location of the beads
- Place the reinforced member.



Wayne L, et al. [4], studied different trigger hole size and location. They found that this affect impact force, crash distance and crash mode. The local peak forces decrease with increasing trigger hole size and crush distance decreases. N. Chase, et al. [5], proposed a method for progressively designs during an automated design optimization study. Different crush was defined along the length of the rail. The main objective of doing this is to increase the absorption energy in a given crush zone. Crush should initiate from tip and progresses from zone to adjacent zone. In traditional methods, we were only focusing on total absorption energy but in this the result is same but crushing is done on progressive basis.

Kitagawa, et al. [6], proposed a buckling analysis method to calculate the efficient position of beading for controlling collapse mode (axial and bending collapse). Yamazaki and Han [7] crashed tubes into a rigid wall and the thickness of tubes are optimized using a response surface method. In this paper the specific energy of absorption (SEA) and the crushing force efficiency (CFE) of the geometries were found out in order to properly analyze what was happening with the different geometries under crash when the different materials were taken.

When progressive buckling occurs, the force displacement curve typically follows a characteristic path [8, 9]. The axial load rises until a first buckle is formed, after which the force decreases significantly. Then folds begin to form, with a small peak in the force displacement curve corresponding to each new fold. The values of the force required to initiate these folds are often significantly less than the maximum force observed at initiation of the first buckling event. Ideally, the formation of folds occurs sequentially from the front of the rail progressing toward the rear during progressive crush.

2. Model Description

2.1 Properties of specimen

Many Models were chosen for the crash simulation. All these models were meshed accurately to get the best results. Tubes with different geometries were chosen. The simulation was performed by taking three different materials for the modelled geometries. The properties of the materials chosen are given in Table 1-4 and dimensions are given in Table-5.

Table 1. Aluminum and Steel properties

Material	E (GPa)	μ	ρ (kg/m ³)
A7075	68.9	0.35	2703
Steel	200	0.3	7850
CFRP	17.1	0.3	1600

Table 2. Aluminum

Yield stress(MPa)	Plastic strain
80	0
115	0.024
139	0.049
150	0.074
158	0.099
167	0.124

171	0.149
173	0.174

Table 3. Steel

Plastic strain	Yield Stress(MPa)
0.0	215
0.004	300
0.03	390
0.15	440
0.3	460
0.4	400

Table 4. Johnson Cook plasticity properties for CFRP

Material	A(Mpa)	B(Mpa)	n	C
CFRP	200	450	0.2	5

Table 5. Dimensions

Model	L	W	D	t
A, S	110	62	300	3.9

Here L=length of rectangular cross section, W=width, D= Height, t=Thickness of section.

2.2 Modelling

After the dimensions were selected for the structures they were modelled using the software ABAQUS 6.14. Then a barrier was modelled which is required to perform the crash simulation. The front rail was modelled with two plates one in the front and the other on the back. The front plate was given an inertial mass and the plate in the back was kept fixed that is a fixed support. The cross-section of the front rail was varied and various internal geometries for cross members were used. The barrier and the structures modelled are assembled together and are used for the simulation. A denotes aluminum. S denoted Steel and C represents CFRP (carbon fiber reinforced plastic).

2.3 Analysis

After the structures were modelled crash simulation was done on all the structures by taking different materials in the ABAQUS 6.14 software. Here the boundary condition ENCASTRE was applied to the nodes. The values of total deformation resulting from the crash and the stress generated were noted.

2.4 Analysis Settings

To do the crash simulation one end of the structure is taken as a fixed support and the barrier is given a velocity of 15.6m/s and is aligned in such a way such that it crashes the other side of the structure. The material of barrier is taken as steel and aluminum to do the analysis in the settings. The direction in which the velocity is to be given is assigned based on the x, y and z directions.

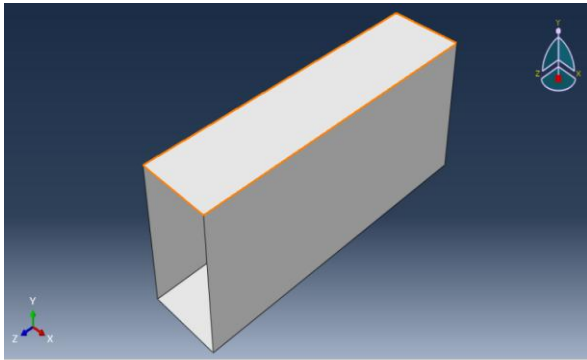

Figure 1. Model 1

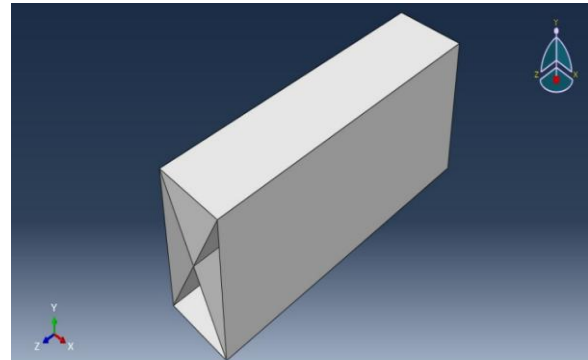

Figure 2. Model 2

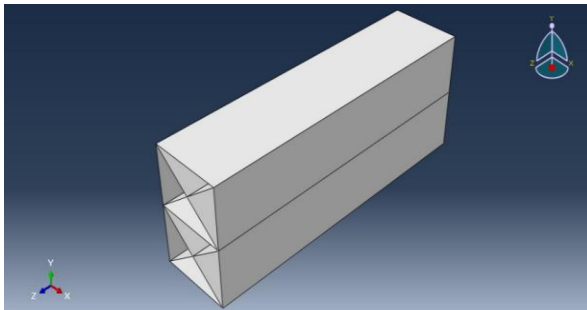

Figure 3. Model 3

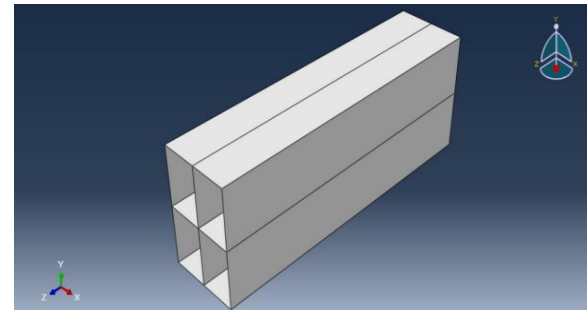

Figure 4. Model 4

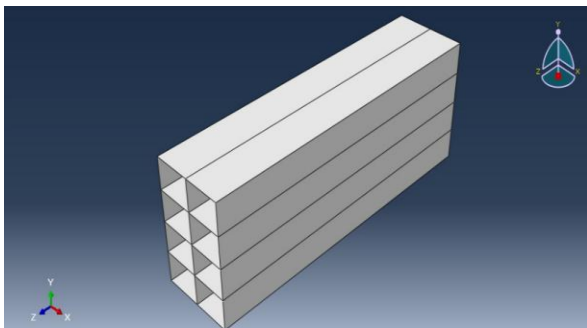

Figure 5. Model 5

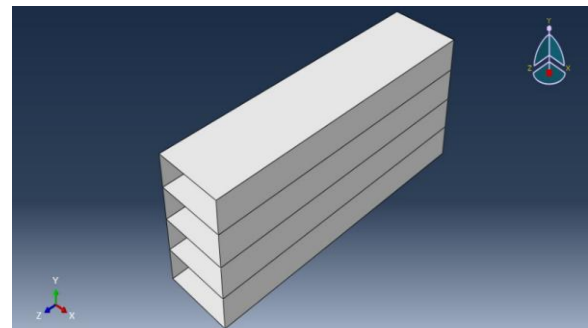

Figure 6. Model 6

Figures 1-6 represent the different cross sections that have been taken to perform the crash simulation. Totally six geometries for cross sections were considered.

3. Results and Discussions

The crash simulation was done for two materials aluminum and steel. In the current work the displacement, specific energy of absorption and the crushing force efficiency of the structures under crash were evaluated and used to compare the suitability of the material and design chosen.

3.1 Force vs displacement

The force vs Displacement plots of the structures for aluminium and steel (Figure. 7, 8) during the crash shows how the force is affecting the displacement of the member under crash. The crushing length changes as the cross section of the structure changes.

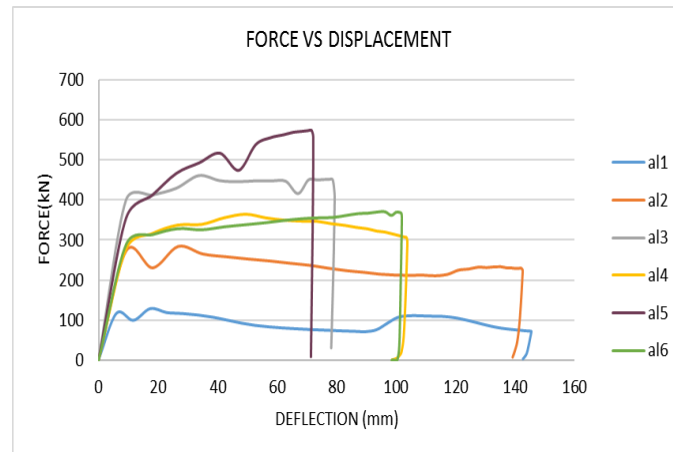

Figure 7. Force vs Displacement of Aluminum

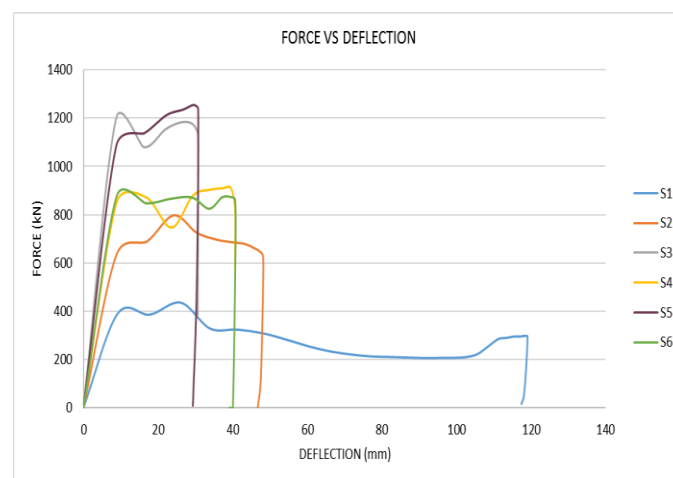

Figure 8. Force vs Displacement of Steel

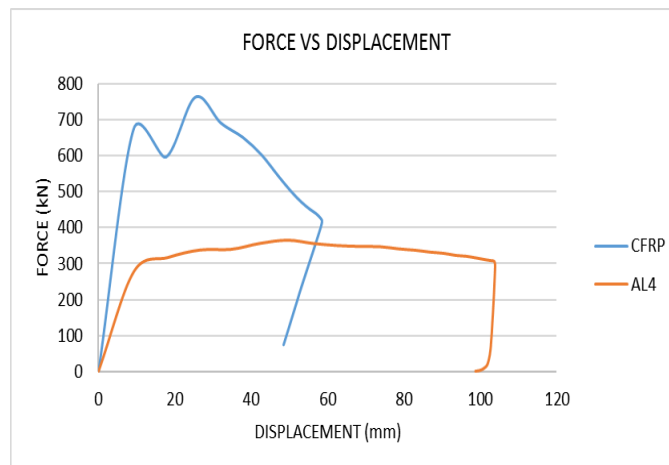

Figure 9. Force vs Displacement of CFRP and aluminum geometry model 4.

From the graphs of force vs Displacement of steel and aluminum structures it can be observed that for structures aluminum model 4, aluminum model 6 and steel model 4, steel model 6 the displacement of the structure with the force applied is in good agreement to the requirement. It means that for these two cross sections the absorption capacity is not too high and not too less but it is in the optimal range such that the member is not too rigid or too flexible. From the force vs displacement plot of the CFRP and aluminum (Figure. 9) it can be seen that the peak load in CFRP is higher as compared to aluminum and the total crushing length of CFRP is lesser compared to aluminum which indicates that the SEA of the CFRP is higher than aluminum, which indicates that CFRP is good energy absorber but the crushing force efficiency is less because the displacement is less.

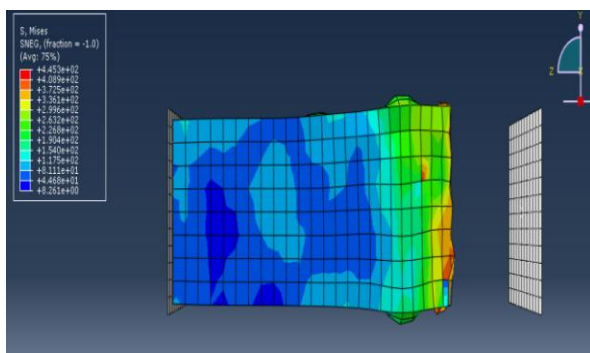

Figure 10. Model 1 Aluminum after crush

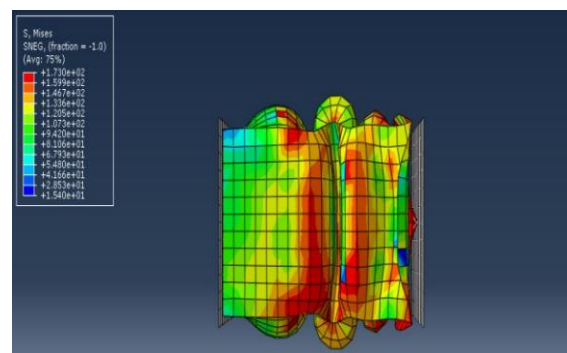

Figure 11. Model 2 Aluminum after crush

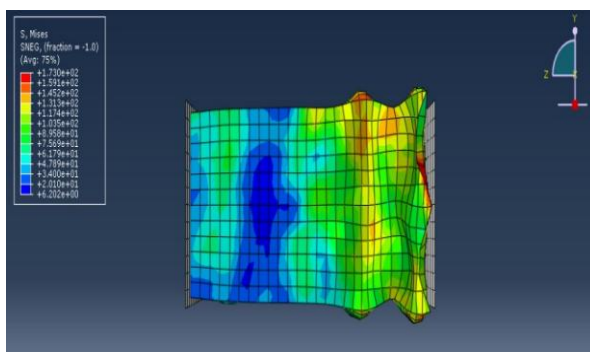

Figure 12. Model 3 Aluminum after crush

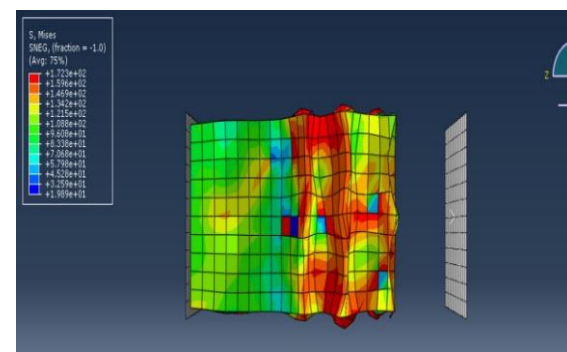

Figure 13. Model 4 Aluminum after crush

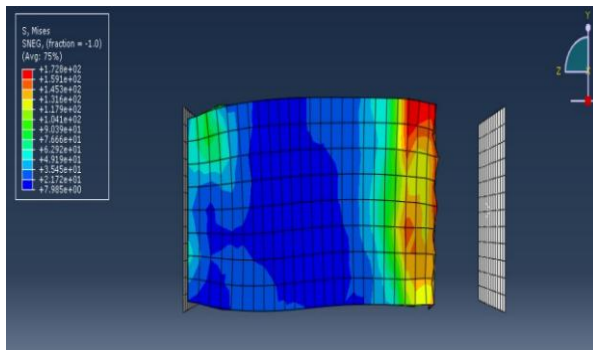

Figure 14. Model 5 Aluminum after crush

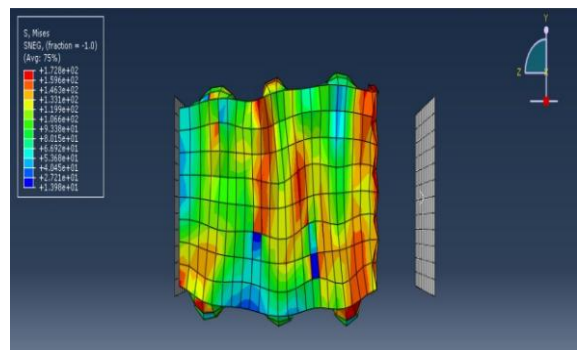

Figure 15. Model 6 Aluminum after crush

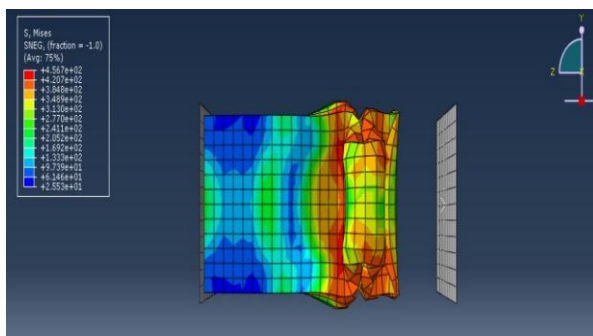

Figure 16. Model 1 steel after crush

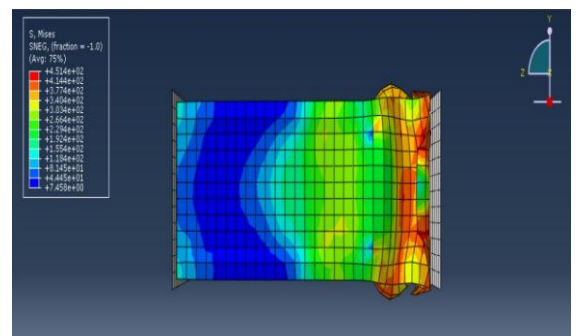

Figure 17. Model 2 steel after crush

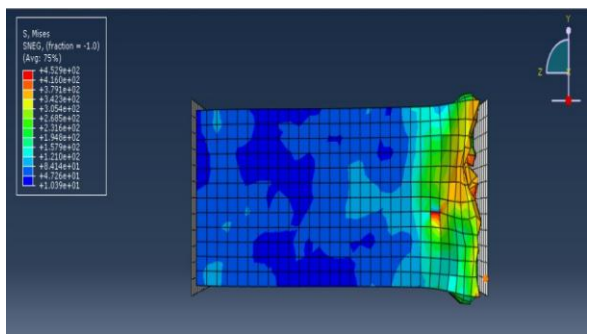

Figure 18. Model 3 steel after crush

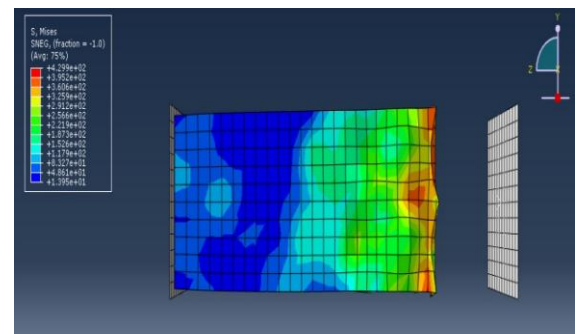

Figure 19. Model 4 steel after crush

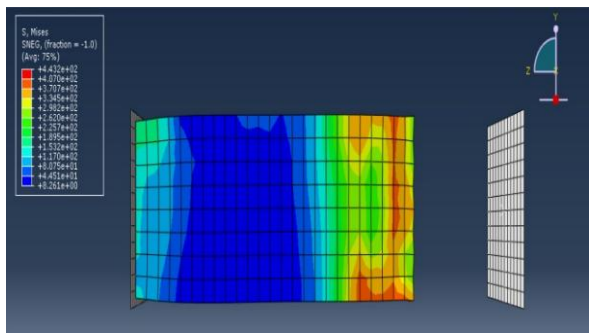

Figure 20. Model 5 Steel after crush

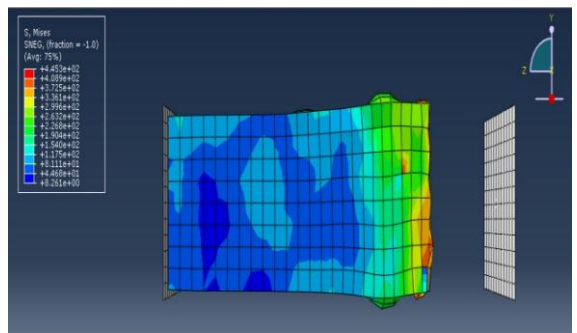

Figure 21. Model 6 Steel after crush

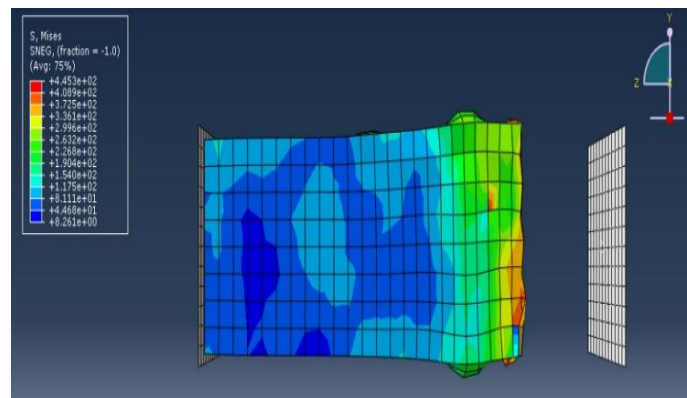

Figure 22. Model 4 CFRP after crush

Figures 10 to 22 show the images for stress values of the front rail for respective cross sections of steel, aluminum and CFRP after the crash simulation. The color of the geometry indicates the magnitude of stress generated starting from red which indicates that area has very high stress and goes on till blue which indicates the area of lowest stress.

3.2 Calculation of SEA and CFE

The specific Energy of Absorption of a structure is given by,

$$SEA = \frac{\text{Total Absorption Energy}}{\text{Column Mass}} = \frac{\int Pd\delta}{M}$$

Here, P is the load, δ is the displacement and M is the mass of the column. All the crash simulation was performed at a speed of 15.6 m/s which is 56 kmph as per the norms for crash regulations.

Example calculation for Aluminum model A2,

$$SEA = \frac{30.301 \text{ KJ}}{1.98 \text{ Kg}}$$

Therefore, SEA=15.303 KJ/Kg.

Similarly, the SEA of all the other structures was calculated (Table. 4).

Table 6. SEA values in J/kg

Model	Aluminum	Steel
1	11232	8839
2	15303	4322
3	11467	2794
4	17806	4713
5	13492	3366
6	16539	4457

It was observed that the SEA of aluminum was higher compared to that of steel structure. The SEA for Aluminum model 4, which is the structure four rectangular cross section was observed to be the highest among metals. The SEA value for CFRP of optimized cross section model that is model C4 is 26314 J/kg.

The CFE or the crushing force efficiency was also calculated for all the structures to see how efficiently the structures were being crushed. The CFE of a structure is given by

$$\frac{\text{Mean load}}{\text{Maximum load}} = \frac{Pm}{Fmax}$$

Here the mean load is given by

$$Pm = \frac{Ea}{l}$$

Where, Ea= Total absorbed energy and l= total crushing length.

Model Calculation:

CFE for Aluminum model 2:

$$\frac{216441.1954}{0.14} = 0.765 \text{ or } 76.5\%$$

Table 7. CFE values (%)

Model	Aluminum	Steel
1	71	56.7
2	76.5	62.8
3	78.4	57.2
4	83.8	65.1
5	73.2	57.03
6	81.9	67.8

It was observed from Table 5 that the CFE of aluminum model 4 was the highest with a value of 83.8%. The CFE for CFRP model C\$4 is 60%.

4. Conclusion

From the values of SEA and CFE of all the structures and the materials taken for crash analysis, it can be concluded that CFRP has the highest SEA of 26.3KJ. The model A4 of aluminum structure has the highest CFE that is 83.8%. It was observed that Aluminum model 4 cross section of the aluminum material had the highest SEA, 83.8% after CFRP, Although CFRP has the highest SEA it has a very low CFE 60% compared to that of the aluminum structure in other cross sections. Steel has lower CFE,57% and SEA 4.3KJcompared to both aluminum and CFRP. Since Aluminum has both the values of SEA and CFE which are required for an optimum crash it is concluded that the Aluminum 4 structure is best suited design for the front rail of the car chassis.

Acknowledgement

The authors wish to thank VIT University, Vellore for the support extended in carrying out this project.

References

- [1] Kim and Hee Chul 2014 Crashworthiness of aluminum/CFRP square hollow section beam under axial impact loading for crash box application *Compos Struct* **112** (2014)
- [2] Wu and Chien-Hsun 2005 Improvement Design of Vehicle's Front Rails for Dynamic Impact *5th European LSDYNA Users Conference* Birmingham UK (2005)
- [3] Kumar, Lalith and Vinod K Banthia 2009 Numerical Simulation for Crashworthiness of Frontal Rail Structure Using Explicit Finite Element Code *SAE Technical Paper* 2009-26-0060
- [4] Li W, Tyan T, Chen G, Chen X M and Shi M F 2005 Numerical investigation of effects of frame trigger hole location on crash behavior *SAE Technical Paper* 2005-01-0702
- [5] Qiu and Na 2015 Crashworthiness analysis and design of multi-cell hexagonal columns under multiple loading cases *Finite Elem Anal Des* **104** 89-101
- [6] Kitagawa Y, Hagiwara I and Tsuda M 1991 Development of a Collapse Mode Control Method for Side Members in Vehicle collisions *SAE Technical Paper* 910809
- [7] Yamazaki K and Han J 1998 Maximization of the crushing energy absorption of tubes *Struct. Optim.* **16** 37-46.
- [8] Guillow S R, G Lu and R H Grzebieta 2001 Quasi-static axial compression of thin-walled circular aluminium tubes *Int. J. Mech. Sci.* **43** 2103-2123
- [9] Zarei H R and M Kröger 2006 Multiobjective crashworthiness optimization of circular aluminum tubes *Thin-walled structures* **44** 301-308