

PAPER • OPEN ACCESS

Solar pv fed stand-alone excitation system of a synchronous machine for reactive power generation

To cite this article: N Sudhakar *et al* 2017 *IOP Conf. Ser.: Mater. Sci. Eng.* **263** 052017

View the [article online](#) for updates and enhancements.

Related content

- [Sliding mode control of direct coupled interleaved boost converter for fuel cell](#)
W Y Wang, Y H Ding, X Ke *et al.*
- [Design and Implementation of nine level multilevel Inverter](#)
K Dhineshkumar and C Subramani
- [A PIPO Boost Converter with Low Ripple and Medium Current Application](#)
S Bandri, A Sofian and F Ismail

Recent citations

- [Garapati Vinayramsatish *et al*](#)

Solar pv fed stand-alone excitation system of a synchronous machine for reactive power generation

Sudhakar N, Siddhartha Jain and Jyotheeswara Reddy K

School of Electrical Engineering, VIT University, Vellore- 632014, Tamil Nadu, India

Email: nsudhakar@vit.ac.in

Abstract: This paper presents a model of a stand-alone solar energy conversion system based on synchronous machine working as a synchronous condenser in overexcited state. The proposed model consists of a Synchronous Condenser, a DC/DC boost converter whose output is fed to the field of the SC. The boost converter is supplied by the modelled solar panel and a day time variable irradiance is fed to the panel during the simulation time. The model also has one alternate source of rechargeable batteries for the time when irradiance falls below a threshold value. Also the excess power produced when there is ample irradiance is divided in two parts and one is fed to the boost converter while other is utilized to recharge the batteries. A simulation is done in MATLAB-SIMULINK and the obtained results show the utility of such modelling for supplying reactive power is feasible.

1. Introduction

SM-based systems may not be capable enough to supply all the reactive power demands of the total load but incorporating it with rest of the grid adds a significant amount of reactive power and power factor correction from the side of SM [1,2]. This paper gives an insight to how these SM system can be utilized without any expense from the main system. A model is proposed to use the solar energy for field excitation of the SM and which when overexcited starts generation the reactive power. There are several types of RPCs like mechanically switched shunt capacitors and reactors, series capacitors, Static VAR Compensator (SVC), Synchronous Condenser and Static Synchronous Compensator (STATCOM). Underground and overhead transmission lines etc.

The technology used with the SM is Wind power excited synchronous generator system [1-3]. Fossil fuel or Hydro turbine coupled synchronous generator system are such that the RPC is done by energizing the SM from the line itself [2]. A Synchronous condenser is an overexcited synchronous motor supplying reactive power thus called as SM-RPC [4]. Generally other synchronous motors the SC doesn't have the shaft open because their main function is to supply reactive power hence they run at no load at the synchronous speed and are not coupled to any mechanical load. There are several techniques for control of excitation [7] of SC like using fuzzy logic [6] or by micro controller [3] or by DC/DC converter [5], controlled bridge circuit etc. [8].

In this paper we show the working and performance of SC fed via a boost converter. A SIMULINK model is made for the analysis of the performance and also to identify the capacity of the SM to generate reactive power [9,10]. The field of the SM is fed via the boost converter. The boost converter is supplied by the solar panel [11] having irradiance [12] varying through the scale. The



format of this paper is as follows. Section 2 discusses the solar panel model and the irradiance input to the panel. Section 3 discusses the design of boost converter and its input via the panel or the batteries. SC output is mathematically calculated in Section 4 to be cross verified to the simulation output. Section 5 is about the complete SIMULINK model and the complete proposed system, it also has describes the major subsystems of the model. In the end Section 6 and 7 are the result and conclusion based on the output of the simulation study.

Figure 1 shows the detailed model of the system. The solar panel is used as a primary input to the converter and the batteries are kept as a backup in case the irradiance falls below a threshold value. The excess energy produced is stored in the rechargeable batteries via the potential bridge which divides the total output of the solar panel.

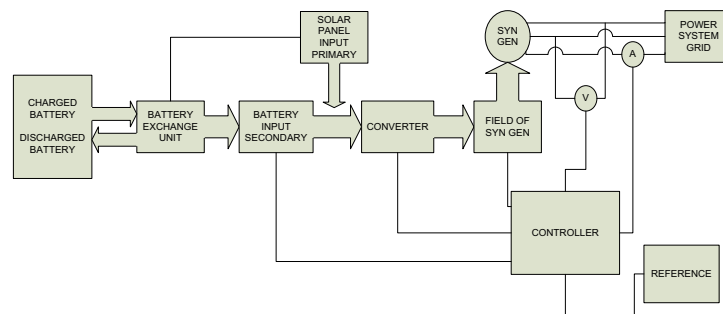

Figure 1. Block diagram of the proposed model

2. Solar panel

The current output from the solar panel is proportional to the illumination or the light intensity falling on it. With the increasing intensity the output of the solar panel increases and also with decreasing intensity the output decreases correspondingly. The two main factors on which the output of the solar panel depends is the irradiance and the temperature. The amount of power generated by the panel depends on the operating voltage of the panel. The operating point of the panel is decided from the V-I characteristics at the point with maximum voltage and current [12].

The complete arrangement of 72 cell is connected across a resistor, the value of this resistor is chosen with respect to the output required [10,11]. A series of 6 solar cell as shown in Figure. 6 (b) is connected repeatedly to make a series of 72 cells. The arrangement of the 6 cell in series as shown in Figure. 8 is clubbed together and similar three such Models are connected in series to form one 18 cell arrangement. Similarly the above 18 cell arrangement is connected in series 4 times to form the final 72 cell arrangement.

2.1. Solar panel simulink model

Thus by supplying the remaining part of the energy to the batteries we use the panel to its full extent. This is achieved in this model by making a potential bridge. The two resistances connected in series divide the output in such a ratio that the output across one is maintained at 24 and the output across the other can be utilized for other purpose like that of charging of the battery.

Out of the total generating capacity of the panel at present irradiance the part of energy needed to supply the converter is taken and the rest is utilized to recharge the batteries. In this way maximum utilization of available energy is done. This will serve in multiple purpose supplying the converter and

at the same time if available the batteries are also recharged thus utilizing the maximum power available and the same batteries can be used when the irradiance falls below the threshold value.

2.2. Battery recharging

The partitioned output from the solar panel is sent to the controlled voltage source which in turn recharges the battery. The output of both the cases is observed and it can be seen clearly that with the potential bridge not only the output is more stabilized but maximum power is also extracted from the solar panel. Finally adding a capacitor of suitable value will give a steady output of 24V. Further improving the voltage profile.

Table 1. RESISTANCE RATIO

R ₁ (Ohms)	R ₂ (Ohms)	V ₁ (Volts)	V ₂ (Volts)	I ₁ (Amps)	I ₂ (Amps)	R ₁ /R ₂
4	5	11	23	2.7	4.8	4/5
80	100	17.5	24	0.22	0.24	4/5
400	500	17.5	24	0.045	0.048	4/5
1600	2000	17.5	24	0.011	0.012	4/5
4000	5000	17.5	24	0.0045	0.0048	4/5
100	150	16.5	20	0.16	0.16	2/3
250	500	18.5	25	0.075	0.048	1/2

From the above table it is clear that the ratio between R₁ and R₂ should be 4:5 in order to maintain a balance between the potential divided in two parts. The only difference the value of the resistance chosen makes is the magnitude of the current. Thus as per the need and limitation of the project it is possible to select a proper value of resistance bound within the ratio of 4:5. For further analysis let us take the value of R₁ = 1600 and R₂ = 2000 ohms. Now in order to maintain the profile constant at 24V for V₂ and 17.5V for V₁ we select different values of capacitance to be added in parallel with average value of the output voltage is tabulated as follows:

Thus from table 2 it can be seen that same as resistance the capacitance should also be in the ratio of 4:5 and the minimum value as found in this case is C₁ = 4F , C₂ = 5F.

Table 2. DIFFERENT VALUES OF CAPACITANCES

C ₁ (F)	C ₂ (F)	V ₁ (Volts)	V ₂ (Volts)
0.1	0.1	19	26.5
0.4	0.5	18.5	26
4	5	17.5	24.7
20	25	17.1	24
24	30	17	24
28	35	17	24

3. Boost converter

The function of boost converter is to step up the input to the required output. The input to the boost converter is either form the solar panel or via the batteries which are used when the irradiance falls below a threshold value. The switching between the solar panel and the dc rechargeable batteries

is done on the basis of the irradiance level [9,11]. If the irradiance falls below the threshold limit the output of the switch is changed from solar panel to the batteries. As long as the irradiance level is more than threshold the output is solar panel otherwise the batteries are connected. As shown in the complete circuit diagram in Figure. 7 and in the complete SIMULINK model in Figure. 14 both. Here the boost converter is designed to step up the input of 24V from the solar panel or the batteries to the required voltage for the field excitation of the SM. The input from the solar panel or the batteries maintained around 24V is boosted to the required voltage to be fed to the field of the synchronous machine in order to over excite it and generate the reactive power. Here the reference value is fixed to be 80 can be made constant or for real time application this is linked to the line shown in Figure. 11, 12, 13 and is explained in section ahead. The PID blocks makes the duty cycle for the reference value and the PWM block generates the corresponding switching pulses. The complete arrangement is shown in Figure. 14.

The above critical values are the minimum value required in order to maintain continuous current and voltage profile. But in order to make a smooth voltage output the value of both L and C is greater than the critical value.

4. Synchronous machine

We know that the total power generated by the SM machine is

$$P_d = \frac{E_o * V}{X_d} \sin\delta + \frac{1}{2} V^2 \left(\frac{1}{X_q} - \frac{1}{X_d} \right) \sin(2\delta) \quad (1)$$

Where, P_d = total power developed

E_o = excitation voltage

V = terminal voltage

X_d = direct axis reactance

X_q = quadrature axis reactance

δ = power angle

Thus for the excitation voltage of $E_o = 80$ we calculate the reactive power as:

$$P_d = \frac{80 * (400)}{34.1} \sin 75 + \frac{1}{2} 400^2 \left(\frac{1}{16.25} - \frac{1}{34.1} \right) \sin(2 * 75) \quad (2)$$

$$P_d = 2194.95W$$

From the above calculated total power generated we can calculate the reactive power as:

$$P_R = 15535VAr$$

Thus the reactive power generated for the excitation voltage of 80V is 15535 VAr. The same is verified in the tabular column followed containing readings of the simulation study for measuring the output reactive power for different field voltages. Table 4 shows the corresponding output power at different field voltage excitation of the SC keeping the parameters of the line constant like the load and the phase difference in this case set it to be active power 1000W and reactive power 5000 VAr and no phase delay in the supply.

Table 3. PARAMETERS OF SYNCHRONOUS MACHINE

Specification	Rating
Frequency	50 Hz
Rated voltage	400 V
Rated power	8.1 KVA
Rated speed	1500 RPM
Inductance (q axis)	0.05175 H
Inductance (d axis)	0.1086 H
Stator resistance	1.62 ohm
Leakage inductance	0.004527 H
Field current	50 A
Field inductance	0.01132 H
Field resistance	1.208 ohm

Table 4. REACTIVE POWERS FOR DIFFERENT FIELD VOLTAGES

Field voltage (Volts)	Total power (Watts) *10 ⁴	Active power (Watts) *10 ⁴	Reactive power (VAr) *10 ⁴
60	2.45	1.96	0.61
65	2.71	2.15	0.81
70	2.98	2.33	1.02
75	3.26	2.53	1.25
80	3.55	2.72	1.49
85	3.84	2.91	1.75
90	4.15	3.12	2.03
95	4.47	3.31	2.32
100	4.79	3.52	2.63

All the blocks modelled so far are now connected together to complete the full model and thus further observe the working of the SM shown in Figure. 2. A three phase ideal AC source supplies the synchronous machine and a three phase parallel RLC is also added in order to vary the consumption of real and reactive power.

The synchronous machine is kept at no mechanical load running at synchronous speed and its field is supplied by the boost converter. The boost converter is fed via the solar cell or the batteries as per the availability. The synchronous machine running at synchronous speed is overexcited by increasing the field voltage in order to start generating reactive power. With the changing reactive power demand in the line the excitation voltage of the machine is changed to match up with the need.

The parameters considered are the variable irradiance ranging from 500 to 1050 W/m² and further reducing below 500 toward the end. For the part of SP a series of 6 cell was repeated multiple time to achieve 72 cell SP.

The error between the reference value and the actual output in the boost converter is sent to the PID controller which generates the corresponding duty cycle and this duty cycle is converted to the

gate pulses for the IGBT in the PWM block. Further SM of the rating 50 Hz 400 V 8.1 KVA 1500 RPM is selected from the available models and is run at the synchronous speed externally.

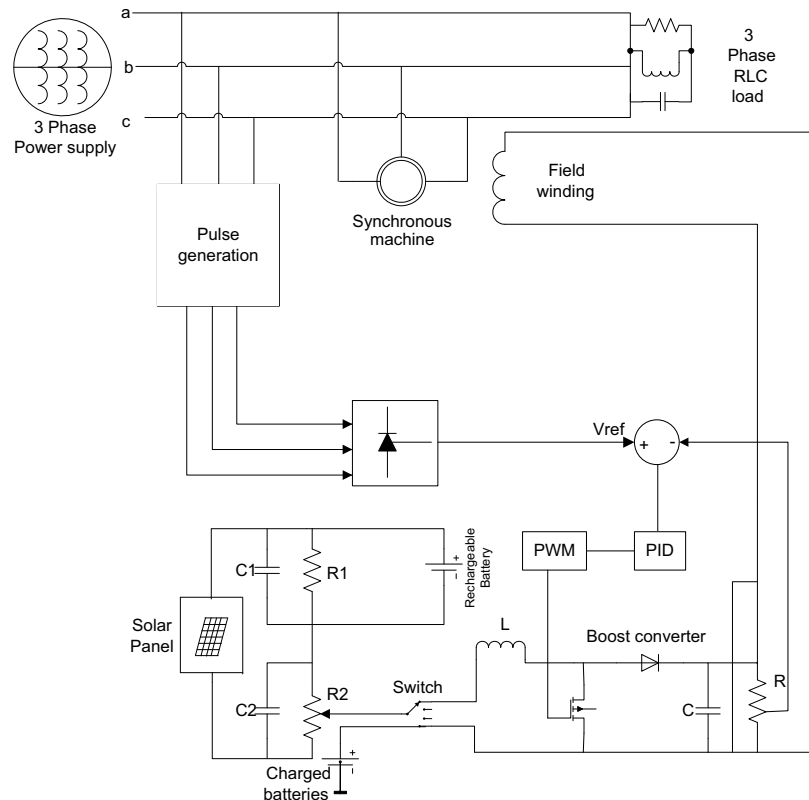
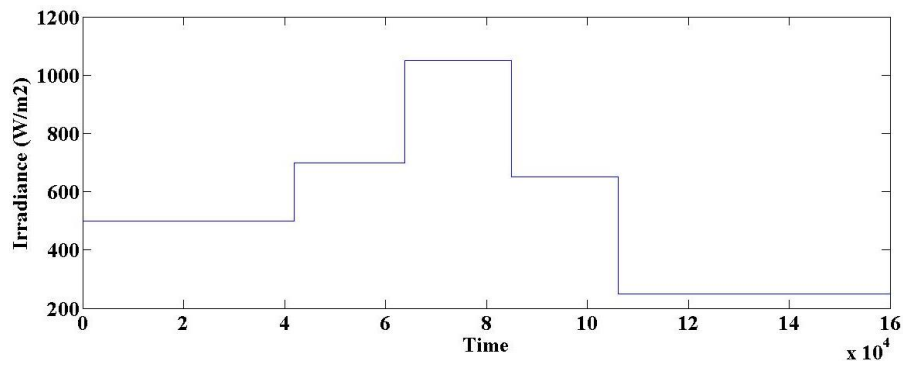

Figure 2. Complete topology of the proposed system

5. Result and Discussion

The input value starts from 500 and reaches its peak to 1050 at mid-day. With the block of time delay the simulation time is depicted as the time of the day and thus in same manner the irradiance value is also changed correspondingly. The batteries are only used when the irradiance is lower than 500. Thus till the irradiance is below the threshold value the supply to the boost converter is continued by the secondary source that is the DC stored batteries.

The output taken across the resistor R1 is supplied to rechargeable batteries thus in this way with better output voltage profile and reduced ripples part of the SP output is also utilized to recharge batteries. Rather than wasting energy complete utilization of the energy is done.



(a)

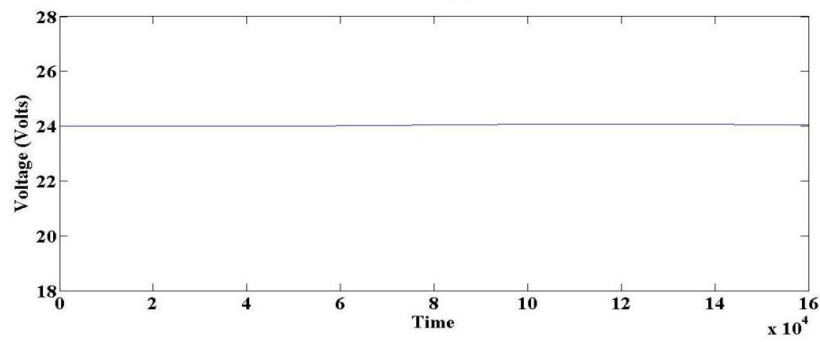

(b)

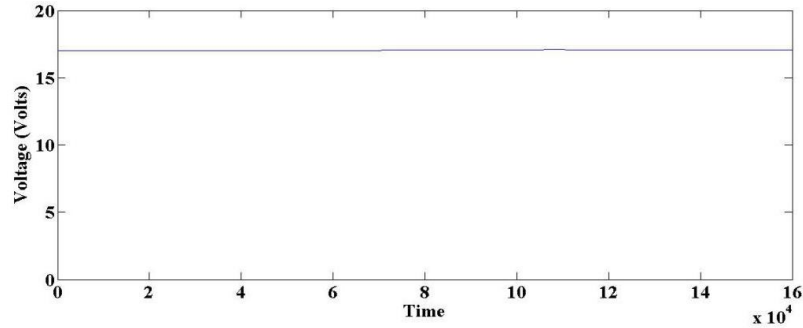

(c)

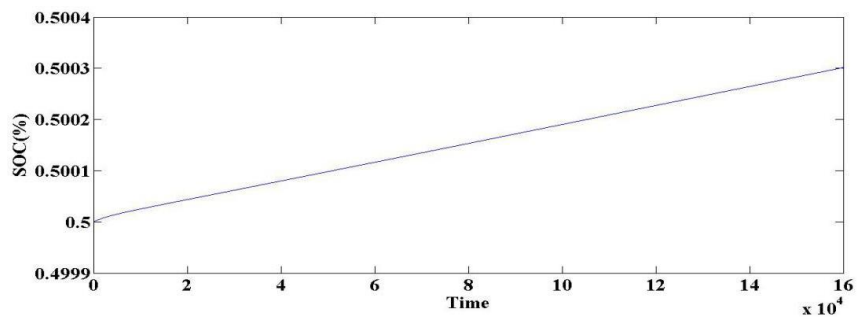

(d)

Figure 3. (a) Irradiance input (b) Part of Voltage output of solar panel to be fed to boost converter (c) Part of Voltage output of solar panel input to the battery (d) State of charge of the battery

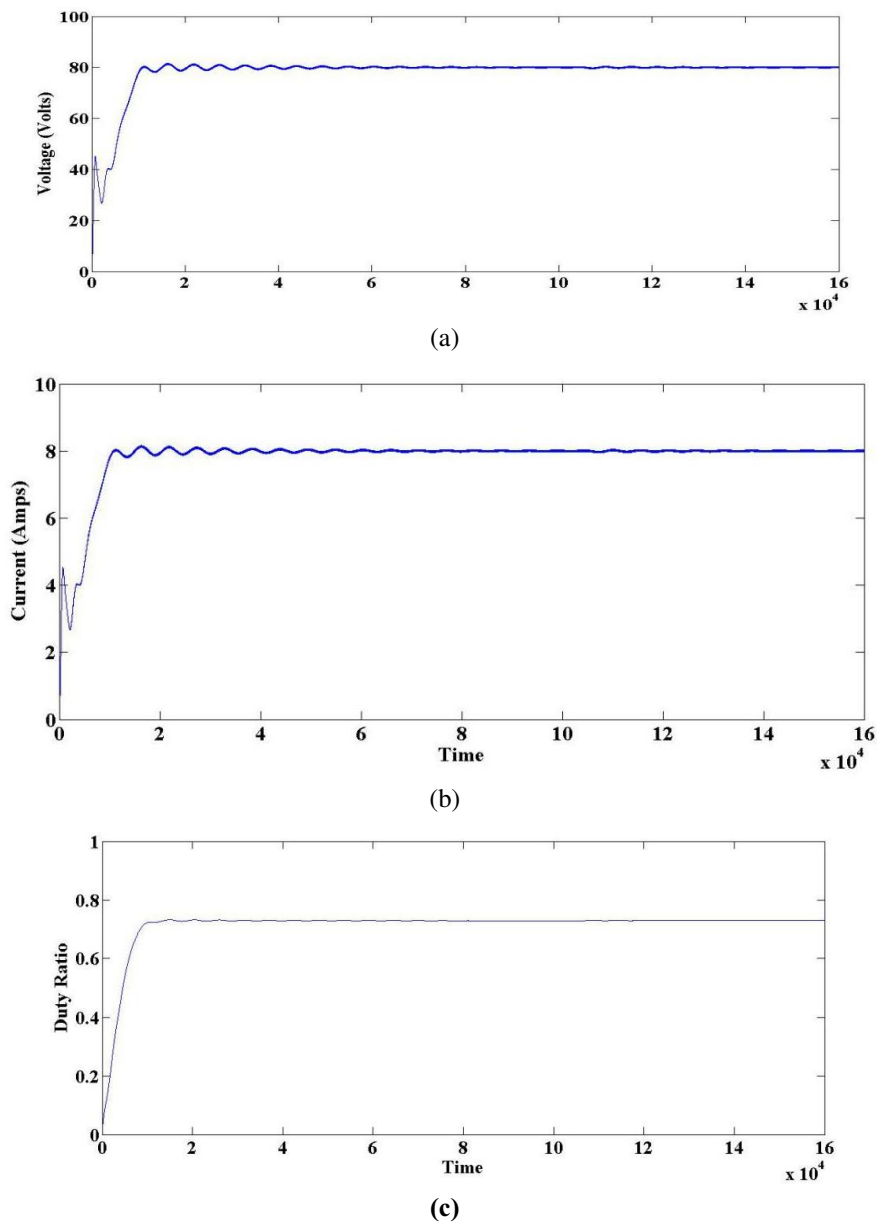

Figure 4. (a) Boost converter output voltage **(b)** Boost converter output current **(c)** Duty cycle

The SM is fed with a constant speed here in this case to be 1500RPM in order to show the coupling with the shaft of the prime mover and this speed is maintained constant throughout the time of simulation. Figure. 5 (a) shows the constant speed of the SC. The total output power, active power and reactive power is shown in Figure. 5 (b), Figure. 5 (c) and Figure. 5 (d) respectively.

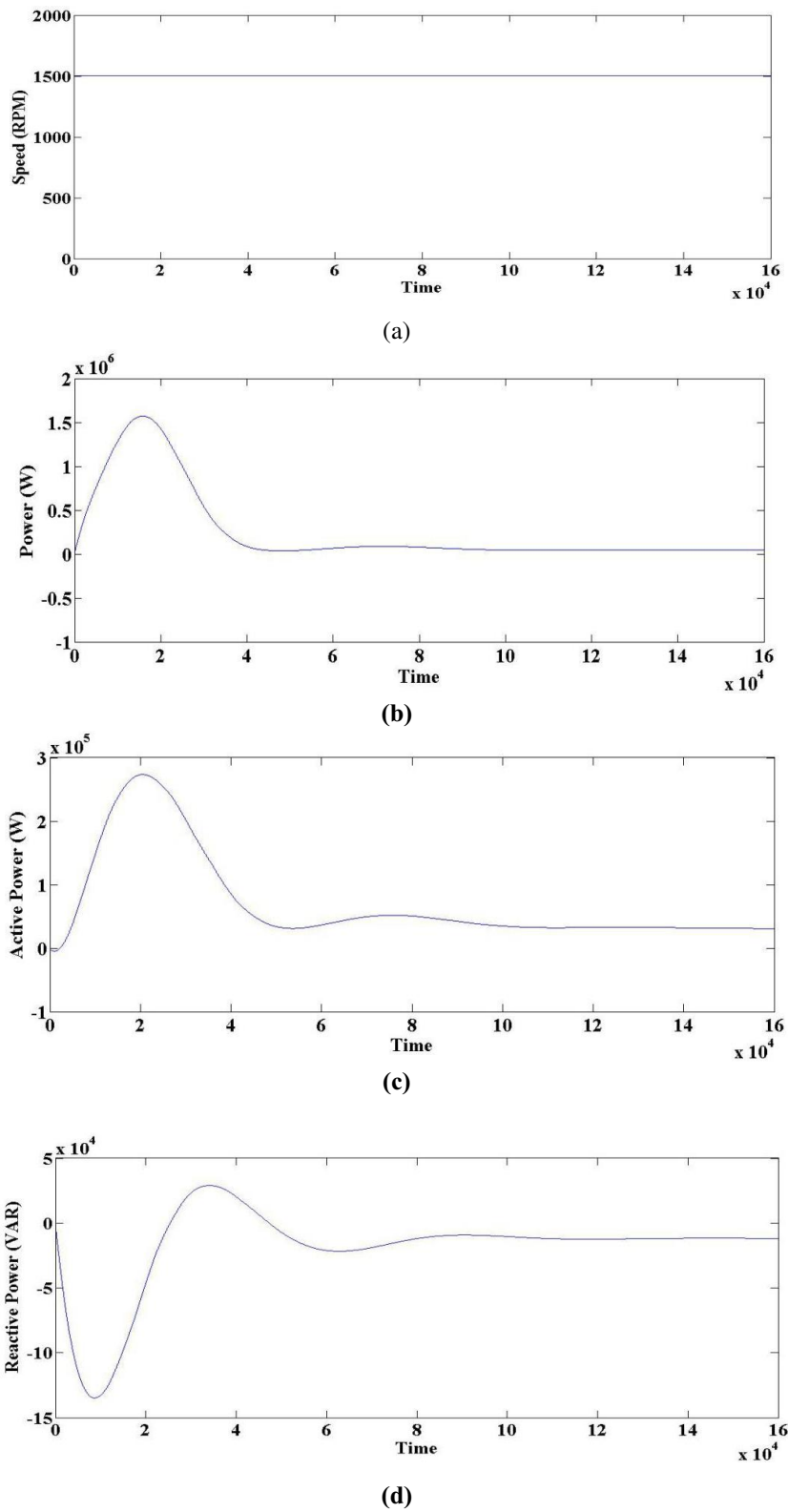

Figure 5. (a) SC speed in rpm (b) SC total output power (c)SC Active power(d)SC Reactive power

Stator current in all the three phases a, b, c is shown in Figure. 6 (a). The three phase line voltage and current that is between the ideal source load and the SC is shown in Figure. 6 (b) and Figure. 8 (c).

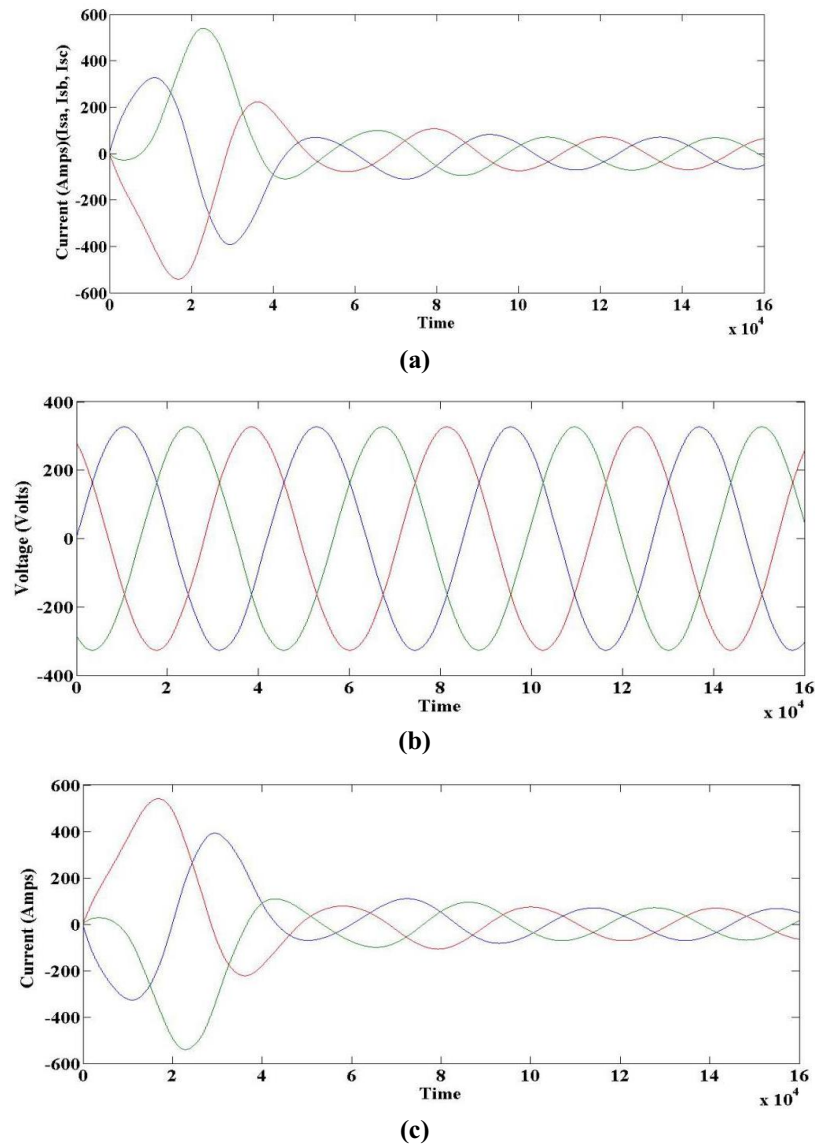

Figure 6. (a)Stator current of 3 phases a, b and c (b)Line Voltage (c)Line Current

6. Conclusion

The reactive power using the proposed system is best utilized by installing it at the substation. With a set of SM installed in the distribution side of the grid not only the power loss in the transmission is reduced but better power factor control is also obtained thus increasing the stability and quality of the power. Also the fuel used is solar power and unlike other fuels like diesel etc. there is no emission of gasses or any kind of pollution and there is no transportation of fuel included hence completely removing the cost of transportation cost. This system also has potential to produce real power so it can easily converted from reactive power source to main power source as the generation is

to be distributed with the growing demand of power with is system the present need of reactive power is met and the future increasing demand can also be supplied.

References

- [1] Balduino Rabelo Power Plants , Wilfried Hofmann, Martin Tilscher and Andreas Basteck 2004 “Voltage Regulator for Reactive Power Control on Synchronous Generators in Wind Energy NORPIE Trondheim, Norway
- [2] Mohamed A A, Elshaer M and Mohammed O A 2010 Reactive power compensation control for stand-alone synchronous generator-based wind energy conversion system *IECON 2010 - 36th Annual Conference on IEEE Industrial Electronics Society* 3222-3227
- [3] Li Wang and Shiang-Shong Chen 2004 DC excitation control of a wind induction synchronous generator using a micro-controller *Proceedings of IEEE Asia-Pacific Conference on Circuits and Systems* **2** 1173-1176
- [4] Constantin Ghita, Aurelian Craciunescu, Valentin Navrapescu, Ioan Dragos Deaconu, Aurel –Ionut Chirila, Ion – Daniel Iliina 2010 Optimal reactive power compensation using synchronous generators *International Conference on Renewable Energies and Power Qualit (ICREPO’10) Granada (Spain)*
- [5] Barakat A, Tnani S, Champenois G and Mouni E 2012 Direct control strategy of synchronous generators using DC/DC converter *IECON 2012 - 38th Annual Conference on IEEE Industrial Electronics Society* 1737-1741
- [6] Sumina D, Erceg G and Idzotic T 2005 Excitation control of a synchronous generator using fuzzy logic stabilizing controller *European Conference on in Power Electronics and Applications* 6
- [7] Kassem A M and Abdelaziz A Y 2014 Reactive power control for voltage stability of standalone hybrid wind–diesel power system based on functional model predictive control *IET Renewable Power Generation* **8(8)** 887-899
- [8] Shoudao Huang, Zhaohui Yang and Gao Jian 2008 Study and design of the hybrid excitation synchronous generator operating constant voltage over a wide range of speeds *IEEE Vehicle Power and Propulsion Conference* 1-5
- [9] Christophe Batard, Frédéric Poitiers, Christophe Millet and Nicolas Ginot Simulation of Power Converters Using Matlab-Simulink <http://dx.doi.org/10.5772/46419>
- [10] Vandanakhanna, Bijoy Kishore Das and Dinesh Bisht 2013 MATLAB/SIMELECTRONICS Models Based Study of Solar Cells *International journal of renewable energy research* **3(1)**
- [11] S Daison Stallon, K Vinoth Kumar and S Suresh Kumar 2012 High Efficient Module of Boost Converter in PV Module *International Journal of Electrical and Computer Engineering* **2(6)** 758-781
- [12] Usha Bajpai and Kalpana Singh 2009 Estimation of instant solar radiation by using of instant temperature *Acta Montanistica Slovaca* 189-196