



ORIGINAL ARTICLE

# An investigation of metal flow during friction welding of SA 213 tube to SA 387 tube plate with backing block



S. Pandia Rajan<sup>a</sup>, S. Senthil Kumaran<sup>b,\*</sup>, L.A. Kumaraswamidhas<sup>a</sup>

<sup>a</sup> Department of Mechanical Engineering and Mining Machinery Engineering, Indian Institute of Technology (ISM), Dhanbad, Jharkhand 826004, India

<sup>b</sup> Department of Mechanical Engineering, R & D Centre, RVS Educational Trust's Group of Institutions, RVS School of Engineering and Technology, Dindigul, Tamil Nadu 624005, India

Received 4 December 2015; accepted 30 March 2016

Available online 16 April 2016

## KEYWORDS

FWTPET;  
Filler plate;  
Microstructure;  
Micro hardness;  
Finite element analysis;  
Hardness

**Abstract** Friction welding is widely used as a large scale production method for fabrication in various industries such as automotive, aeronautic and other industries. Friction welding of tube to tube plate using an external tool (FWTPET) is an innovative friction welding process which is accomplished of manufacturing leak proof high quality weld joints with good mechanical properties. In this study, the friction welding is carried out to weld two dissimilar materials of SA 213 tube to SA 387 tube plate with three different filler materials as brass sheet, filler plate and steel ball using an external tungsten carbide tool to enhance and validate the flow of metal pattern toward the center of tool axis. The micro structural studies are made to reveal about the welding configuration locate and discover the flow of metal path toward the center of the workpiece, then it is followed by the hardness test which ensures a high hardness value at welded zone determines the flow of metal toward the center of the hole has strong bonding structure. Finally, the workpiece with filler material and steel ball is used by the radiography test and the analysis is done by using ANSYS software.

© 2016 Faculty of Engineering, Alexandria University. Production and hosting by Elsevier B.V. This is an open access article under the CC BY-NC-ND license (<http://creativecommons.org/licenses/by-nc-nd/4.0/>).

## 1. Introduction

In recent years, the remarkable development in material fabrication has been examined in the field of materials processing.

\* Corresponding author.

E-mail addresses: [spandiarajan1972@gmail.com](mailto:spandiarajan1972@gmail.com) (S. Pandia Rajan), [sskumaran@ymail.com](mailto:sskumaran@ymail.com) (S. Senthil Kumaran), [lakdhas1978@gmail.com](mailto:lakdhas1978@gmail.com) (L.A. Kumaraswamidhas).

Peer review under responsibility of Faculty of Engineering, Alexandria University.

<http://dx.doi.org/10.1016/j.aej.2016.03.040>

1110-0168 © 2016 Faculty of Engineering, Alexandria University. Production and hosting by Elsevier B.V.

This is an open access article under the CC BY-NC-ND license (<http://creativecommons.org/licenses/by-nc-nd/4.0/>).

Friction welding belongs to the category of solid state welding process that produces weld joints due to friction heat generated by the combined effect of axial force and controlled rubbing of faying surfaces [1]. Some of the advantages of friction welding include the ability to weld non-weldable alloys and produce good quality weld joints [2]. The friction welding is a vital metal joining technique and applied in various industrial sectors such as power plants, automobile, electronics and aerospace. Friction welding of tube to tube plate is a new solid state joining technology invented in the year 2006 [3] and it is an innovative joining process which is capable of producing

high quality leak proof joints when compared to other type of welding process such as fusion welding. This process is energy efficient, environment friendly and versatile process when compared to traditional welding techniques. Metal flow analysis will be helpful for understanding and modeling of the process in order to improve the performance [4]. The analysis of metal flow behavior in friction welding for tube to tube plate has been conducted by using various techniques such as brass insertion techniques, filler plate techniques and steel ball insertion technique [5]. In this research paper, the friction welding is carried out to weld two dissimilar materials of SA 213 tube to SA 387 tube plate with three different filler materials as brass sheet, filler plate and steel ball using an external tungsten carbide tool with various input parameters as tool rotational speed, depth of cut and tube projection. The workpiece has holes of diameter 2 mm on its circumference. The micro structural and hardness test has been conducted for the workpiece with three different filler materials to determine the metal flow pattern and the position of metal deposited by possessing higher hardness value in the welded interface zone. To the next, the workpiece with steel ball as filler material is made to radiography test and ANSYS software is used to calculate the friction effect – deformation and thermal effect – temperature distribution on the workpiece along with tool to ensure the position and movement of steel balls during friction welding.

## 2. Experimental procedure

### 2.1. Material selection

#### 2.1.1. Tool material and design

The friction welding is carried out for the material SA 213 tube to SA 387 tube plate by using an external tungsten carbide tool. The cautious evaluation has been taken into account while selecting this external tool. The tool material should possess the mechanical property – hardness value more than the value of workpiece to perform without any interruption during the welding operation. The tool is designed to a particular dimension of about 27 mm diameter and 170 mm in length. The operations such as facing and turning have been done to get a smooth and desired shape of the tungsten tool. Table A.1 shows the chemical composition of the tungsten carbide tool and Fig. A.1 shows the dimensions of the titanium tool used in this work.

#### 2.1.2. Workpiece material and design

In this Investigation, The friction welding is carried out between the two materials such SA 213 and SA 387. The workpiece tube is made up of grade SA 213 and tube plate is made up of SA 387. The chemical composition of SA 213 tube

is shown in Table A.2 and the chemical composition for SA387 is shown in Table A.3

#### 2.1.2.1. Flat plate with tube having holes on its circumference.

The workpiece is designed by possessing a hole of diameter 2 mm on the tube circumference. The material tube is taken as SA 213 and tube plate is taken as SA 387. Fig. A.2 shows the workpiece design of tube plate tube having holes on it. The tube plate has a dimension of about 50 mm \* 50 mm possesses a drilled hole at its center. The tube has a dimension of 19 mm as outer diameter and length of 28 mm.

In this study, totally nine pieces of tubes with holes and nine pieces of tube plate have been taken. A group has three workpieces and totally three groups have been taken and added with filler materials to observe the flow of metal during friction welding. The attachments of filler materials have deployed in three conditions, and the three conditions are filler plate, brass sheet and steel ball.

2.1.2.1.1. *Workpiece with filler plate.* In this condition, the three sets of tube and tube plate have been taken and filler plate which is made up of SA 387 is used and having a thickness of about 1 mm. The dimensions of the filler plate are same as the tube plate having a hole at its center. This filler plate is placed on the upper surface of the tube which has a 1 mm projection with the tube. Fig. A.3 shows the workpiece setup along with the tube projection and Fig. A.4 shows the three sets of workpiece made ready to perform friction welding at various parameters.

2.1.2.1.2. *Workpiece with brass material.* The workpiece is filled with the brass substance to identify the metal flow for this chemical composition. The brass sheet has a thickness of 1 mm and it is rolled along the tube outer surface and it clamped with the help of fixture. A tight fit is made with tube plate and tube and assembled along with the fixture. The brass is combination of alloy of copper and zinc. The properties of brass have a high malleability than the bronze or zinc. Fig. A.5 shows the brass sheet is rolled along the outer surface of the tube with 1 mm tube projection and clamped with the fixture and Fig. A.6 reveals the three sets of workpiece before welding.

2.1.2.2. *Workpiece with steel ball.* The workpiece is filled with the filler material which is steel ball of diameter 2 mm. it is made up of chromium, high carbon and martensite stainless steel. This martensite is very hard state of high carbon steel and when it is heated to annealed conditions, it forms an extremely fine grain structure. The steel ball is inserted around the circumference of the tube to tube plate at different positions. Eight steel balls have been placed at equality distance from the central axis of the tool. In total, three pieces have been taken with the steel ball at different equal positions on the surface of the tube plate. Fig. A.7 shows the schematic diagram of the position of the steel ball in the tube plate.

**Table A.1** Chemical composition of external tool – tungsten carbide.

Tungsten carbide	Element	C	H	Fe	O	Ni	Mo	Ti	V	Pd
	wt. %	0.08	0.015	0.25	0.13	0.75	4.31	0.4	4.5	0.20

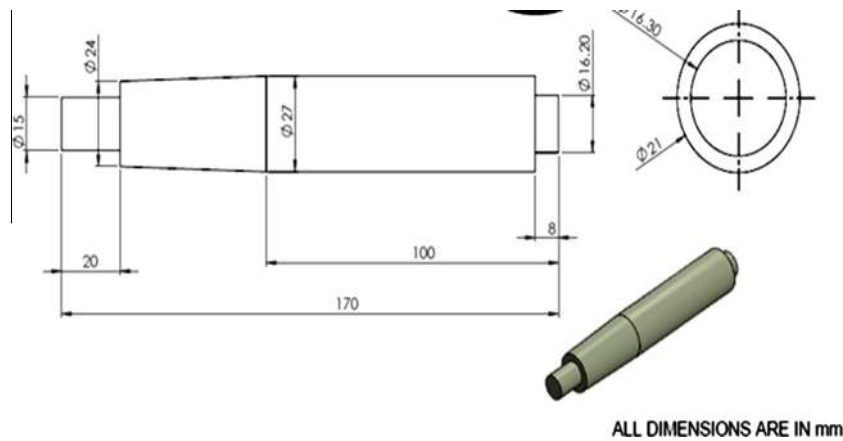

Figure A.1 Titanium carbide – external tool.

Table A.2 Chemical composition of SA 213 tube.

SA 213	Element	Mn	Cr	Mo	Ni	Cop	Ti	Fe
	wt. %	0.51	1.46	0.42	0.046	0.044	0.090	97.1

Table A.3 Chemical composition of SA 387 plate.

SA 387	Element	Mn	Cr	Mo	Va	Ti	Fe
	wt. %	0.75	1.55	0.38	0.041	0.087	96.7

FWTPET process leads to a defect-free weld joint, less distortion and higher strength [6]. This backing block is made up of cast iron and size of about 50 mm \* 50 mm having a center hole of diameter 19 mm and depth of the hole of 26 mm. There is a gap provided between the backing block and the workpiece to have a clearance fit between them. This aspect has been ensured by means of proper selection of dimensions of the tube as well as the hole. Fig. A.10 shows the backing used in the FWTPET process.

Fig. A.8 shows the workpiece with steel before welding and Fig. A.9 shows the three sets of workpiece with steel ball.

2.2. FWTPET process

2.1.3. Backing block design

In this FWTPET process, the backing block is employed to act as fixture to support the workpiece which is clamped in the vertical milling machine. The use of backing block in the

The friction welding of tube to tube plate is carried out in vertical milling machine. This FWTPET process delivers robust weld joints. The FWTPET machine developed in-house is shown in Fig. A.11.

The external tool consists of a shoulder and pin and Fig. A.12 shows the external tool used in this experiment. The tube and tube plate to be welded are well cleaned and made free from all contaminants such as grease and absorbed

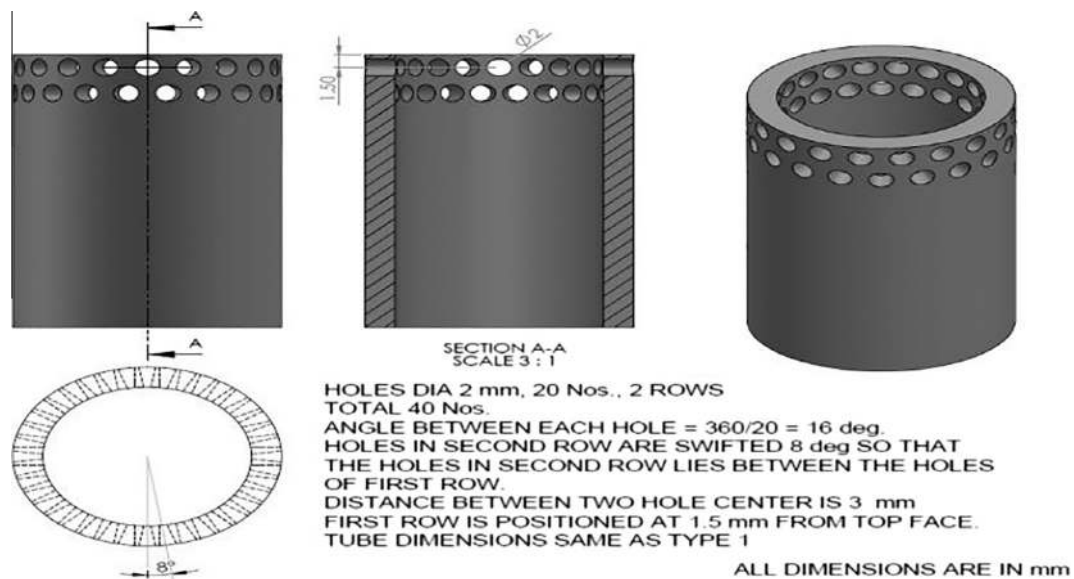

Figure A.2 Tube having holes.



Figure A.3 Workpiece with filler plate SA 387.



Figure A.6 Three sets of workpiece with brass sheet.



Figure A.4 Three sets of workpiece with filler plate and tube projection.



Figure A.5 Workpiece with brass sheet on its surface.

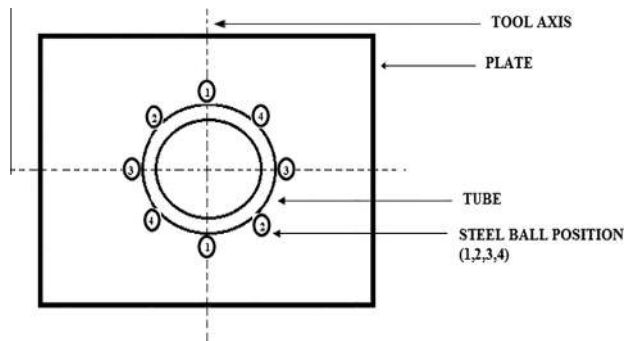

Figure A.7 Schematic diagram of steel ball position.



Figure A.8 Workpiece with steel ball on its surface.

film. A suitable hole was drilled in a plate, and the tube was fitted and assembled in the FWTPET machine table. The FWTPET machine consists of a tool holder, spindle, table and a supporting structure.

In this practice, the tool is attached to the tool holder then it is made to rotate at a required speed and the speed is assorted for various conditions. The filler material is placed



**Figure A.9** Three sets of workpiece with steel ball before welding.



**Figure A.10** Backing block used in FWTPET process.

on the upper surface of the workpiece, the tool is made to move downward toward the upper surface of the filler material, the workpiece is supported by means of backing block



**Figure A.11** FWTPET machine (developed in-house).

and the required depth of cut and feed is given to the tool. Here, the friction will take place between the tool, filler material and the workpiece due to the rotational force of the tool. The heat is generated between these materials. When the filler material and the workpiece metal attain its melting temperature, the metal starts to plasticize and the metals start to move toward the center of the tool axis due to the rotary action of the tool and it fills the gap between the tube plate and the tube. In this study, various set of experiments have been carried out with three sets of tool rotational speed of 730 rpm, 1320 rpm and 1800 rpm with a constant depth of cut of 0.8 mm and with zero projection level. [Table A.4](#) shows the input values given to conduct the experiment for the workpieces with three types of filler materials.

The experiment is processed for the group of three workpieces with each filler material, the friction welding is done for total nine workpieces with three filler materials and [Fig. A.13](#) shows the three sets of workpiece after friction welding with bronze sheet as filler material. [Fig. A.14](#) shows the workpiece after friction welding with filler plate and [Fig. A.15](#) shows the workpiece after friction welding with steel ball as filler material.

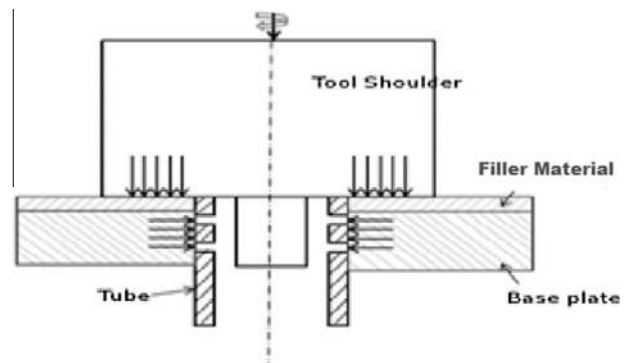

**Figure A.12** Schematic diagram of tool, filler material and the workpiece.

### 2.3. Microstructure study

The optical electronic microscope is used to examine the micro structure characteristics of the friction welding for the workpiece with the various filler materials. Authenticity of welded joints was analyzed to locate and discover the flow of metal path toward the center of the workpiece which is carried out through the micrographs of the weld zone. The power hacksaw blade is used to slash the workpiece after welding with filler materials into four equal parts from its center. The sliced pieces are then processed for hot setting which is prepared by the mixture of hot setting powder. To obtain the better examination of workpiece in microscopic level, the various processes are carried out. The dry belt machine is used to remove the more irregular scratches on the upper surface of the workpiece. Then the different sets of grade sheets are used to remove the fine scratches on the welded workpieces. Fig. A.16 shows the welded workpiece with filler material is fixed in the microscope to identify the microstructure of the welded workpiece. The chemical name called Nital etchant was applied on the workpiece and it is made to dry in hot air for 10 s to get an enhanced microstructure of the workpiece. The chemical composition of the NITAL etchant is 100 ml of Ethanol and 1–10 ml of  $\text{HNO}_3$  [7]. This chemical is applied to the entire welded workpiece which is obtainable to do microstructure with various magnifications.

### 2.4. Vickers hardness test

The welded workpiece with filler material is processed to find out the hardness of the material at three different locations in the workpiece to identify the flow of metal that contains the higher hardness value as the metal flows in a path. The three different locations such as welding interface area, heat affected zone and the base metal have been measured by using Vickers hardness testing machine. The Vickers hardness testing machine is shown in Fig. A.17

### 2.5. Radiography test

The radiography test is carried out to explore the workpiece to inspect the materials for hidden flaws and flow of metals by using the high energy photons. In this test, the workpiece with steel ball as filler materials has been considered and the three sets of workpiece carried out for friction welding at tool

rotational speed of 730 rpm, 1320 rpm and 1800 rpm. The radiography test has been conducted for three materials as per the ASTM International norms.

### 2.6. Modeling and FEA

In this study, the three dimensional modeling and the finite element analysis are carried out only for the workpiece with filler material as steel ball. The steel is positioned at a particular place to analyze the movement of metal flow during the friction welding. The frictional effect is studied to obtain the deformation occurred in the workpiece during welding and the thermal effect is analyzed to measure the temperature distribution and the total heat flux on the workpiece and the combination of tool and the workpiece.

#### 2.6.1. Modeling

The three dimensional modeling is modeled and developed by using solid works designing software [8]. In this design, the tube with hole, tube plate and the filler material with steel ball at various positions is designed to obtain the movement of metal flow. In this study, the filler material steel ball is considered for the modeling and the finite element analysis. The coordinate system provided to this modeling is default where temperature has to be at atmospheric condition and the contact shown between the tube and plate is given as curve on which workpiece is moving under the exploit of its rotary forces. Fig. A.18 shows the modeling of workpiece with filler material steel ball around the tube corners.

#### 2.6.2. Finite element analysis

In this study, ANSYS analysis software is used to conduct finite element analysis for the solid material [9] only for the workpiece with filler material as steel ball. The frictional and thermal effect is measured to obtain the deformation, temperature distribution and heat flux obtained during the welding process. In frictional effect, the type of physics and analysis type is taken as structural and explicit dynamics module. In thermal effect, the type of physics and analysis type are considered as thermal and steady state module.

## 3. Results and discussion

### 3.1. FWTPET sample welded

The analysis of microstructure was carried out by comparing micrographs obtained with help of electronic microscope with various magnification levels. The friction welding is carried out with three varying speeds of 730 rpm, 1320 rpm and 1800 rpm with depth of cut of 0.8 mm and zero level of tube projection. The friction welding carried out in 1800 rpm for three workpieces with three filler materials is considered for this microscopic analysis. It is observed that the tool rotation at higher speed has a better joint strength and more heat is produced due to friction between them. Figs. A.19–A.21 show the microstructure of the workpiece with filler material as brass sheet, filler plate and steel ball respectively.

The three microstructures of the workpiece with filler materials as brass sheet, filler plate and steel ball reveal that the rotational speed of the tool at 1800 rpm produces more friction

**Table A.4** Various experimental run for the FWTPET process.

S. No	Workpiece with filler materials	Speed (rpm)	Depth (mm)	Projection (mm)
1	Brass sheet	730	0.8	0
2	Steel ball	730	0.8	0
3	Filler plate	730	0.8	0
4	Brass sheet	1320	0.8	0
5	Steel ball	1320	0.8	0
6	Filler plate	1320	0.8	0
7	Brass sheet	1800	0.8	0
8	Steel ball	1800	0.8	0
9	Filler plate	1800	0.8	0



Figure A.13 Workpiece after welding with bronze sheet.



Figure A.14 Workpiece after welding with filler plate.



Figure A.15 Workpiece after welding with steel ball.

between the tool and the workpiece. Due to the frictional effect, a huge amount of heat is produced between the workpiece and filler material. Hence the metal starts to melt when attaining its melting temperature. The micrographs show a flow of metal is more at the center of the tool and these molten

metals fill the two layer of the hole made in the workpiece and flows toward the center and creates a strong metallurgical bonding between the tube and tube plate possessing a gap between them. The clear view of the microscopic structure has a huge flow of metal at the welded interface and flows



Figure A.16 Workpiece clamped in electron microscope.



Figure A.17 Vickers hardness testing machine.

through the center primarily due to the rotary action of the tool at higher speed.

### 3.2. Vicker hardness measurement

The micro hardness testing was conducted for the welded workpiece with filler material through FWTPET process. Hardness values are obtained using a Vickers hardness micro testing with a load of 1 kg, and a loading time of 25 s for each sample. The micro hardness has been calculated for the workpiece with hole at various zones such as base metal of tube and plate, heat affected zone of tube and plate, refined zone of tube and plate, and weld interface. Table A.5 shows the hardness

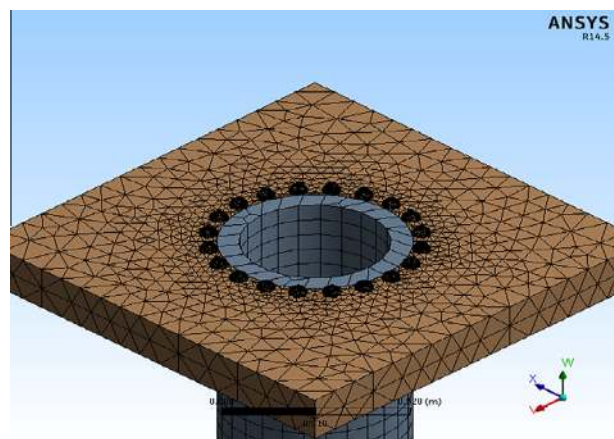

Figure A.18 modeling of workpiece with steel ball.

value for each zone for workpieces with three filler materials and Figs. A.22–A.24 reveals the value of micro hardness plot of the sample welded workpiece with filler material brass sheet, filler plate and steel ball respectively.

The hardness value of the workpiece with hole on its circumference with filler materials such as filler plate, brass sheet and steel ball shows different hardness values measured at various zones in the workpiece. The workpiece with filler material such as filler plate, brass sheet and steel ball has a maximum value of 240 Hv, 193 Hv and 290 Hv respectively at the welded interface zone. The higher hardness value at welded zone determines the flow of metal toward the center of the hole has strong bonding structure. The hardness value of various zones has a lesser value than that of welded interface zone. Hence majority of metal flow toward the center due to the rotary force of the tool attains the peak hardness value at the center. From the result it is clearly evident that the steel balls move toward the center of the tool axis and have a hardness value of 290 Hv. It is mainly due to the fine refinement of the grains at the weld interface and optimum heat generation is produced in between tube to tube plate for achieving good mechanical and metallurgical bond.

### 3.3. Radiography test analysis

In the friction welding process, the workpiece with filler materials as steel ball has a good metallurgical bonding and higher hardness value. The radiography test has been conducted for the workpiece with steel ball for various rotating speed of the tool as 730 rpm, 1320 rpm and 1800 rpm. Figs. A.25–A.27 shows the radiography test for workpiece with steel ball at various tool rotational speeds of 730 rpm, 1320 rpm and 1800 rpm.

The three radiography results show the steel ball moves exactly toward the center of the tool axis and image of the steel ball in the workpiece progressed in rotary motion according to the tool alignment. Eight steel balls are placed in the workpiece and the Experiments are repeated by keeping the steel balls at different positions around the tube to tube plate and it is also observed that the weld joints are free from defects such as crack and porosity [10].



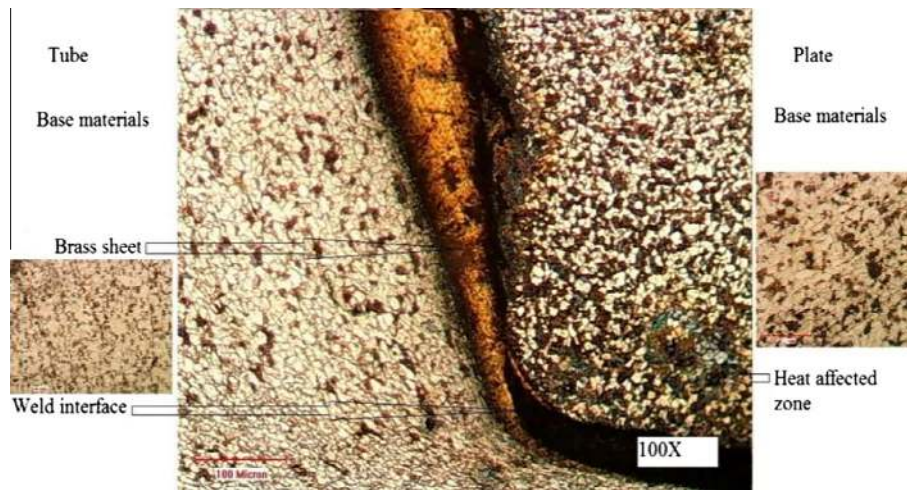

**Figure A.19** Microstructure of the workpiece with brass sheet (1800 rpm).



**Figure A.20** Microstructure of the workpiece with filler plate (1800 rpm).



**Figure A.21** Microstructure of the workpiece with steel ball (1800 rpm).

### 3.4. FEA analysis

#### 3.4.1. Workpiece with steel ball – frictional and thermal effect

The workpiece with filler material as steel ball is considered for finite element analysis to identify the flow of metals toward the

tool center. Initially, the welded workpiece with steel ball has been meshed well each other with the external tool tungsten carbide tool as per the default conditions. The values assigned in this analysis are as per the metric unit systems. Fig. A.28 shows the tungsten carbide tool is fully meshed with the

**Table A.5** Hardness value of workpiece with filler materials.

S. No	Hardness measurement at different zones	Hardness value for workpiece with brass sheet	Hardness value for workpiece with filler plate	Hardness value for workpiece with steel ball
1	Base tube	165	190	196
2	Heat affected tube	172	198	229
3	Knuched tube	181	209	245
4	Welded interface	193	240	290
5	Knuched plate	182	225	256
6	Heat affected plate	176	217	239
7	Base plate	171	212	220

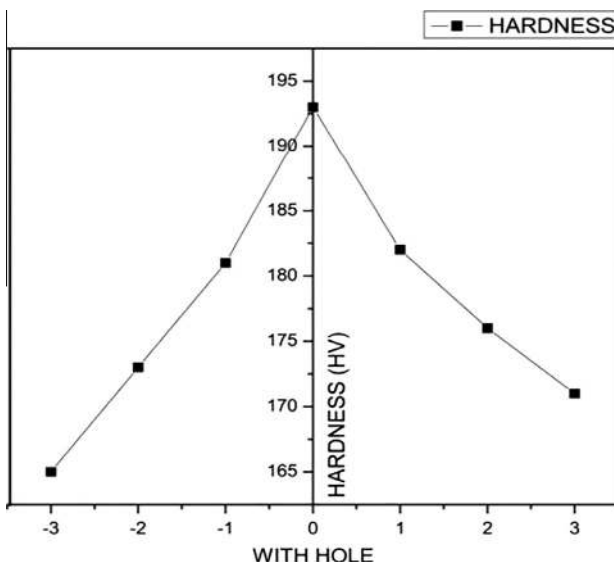
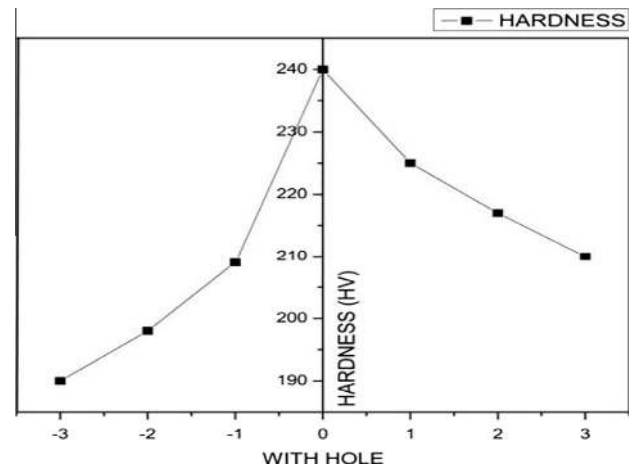

**Figure A.22** Micro hardness for workpiece with brass sheet.

workpiece. From this structure, we have determined the friction and thermal effect for this workpiece.

**3.4.1.1. Frictional effect – deformation.** Friction is both a necessity and a disadvantage in engineering design. There is a relative motion between the two materials when they are in contact with each other produced by the combination of linear displacement tangential to the contact plane, angular displacement with respect to a tangential axis and angular displacement with respect to normal axis [11,12].

The frictional effect has been analyzed for the tube alone. Fig. A.29 shows the frictional effect on all over the tube. The value of about 23.565 MPa and 82.396 MPa was recorded for the minimum and maximum values respectively for equivalent stress across its structure. Graph 1 shows the variation of effect over the period of the time. Time is measured in seconds in x axis whereas stress is calculated in MPa in Y axis.



**Figure A.23** Micro Hardness for workpiece with filler plate.

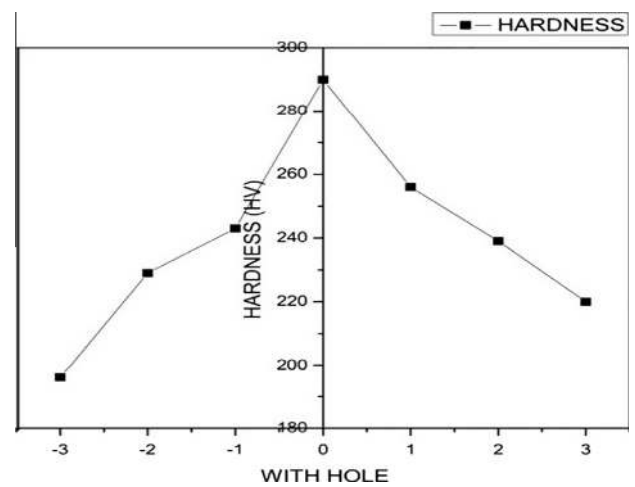

**Figure A.24** Micro Hardness for workpiece with Steel ball.



**Figure A.25** Radiography result – steel ball (730 rpm).

The frictional effect has been analyzed for tube plate. Fig. A.30 shows the frictional effect on all over the tube plate with steel on its upper surface. In this case, the value of about 0 MPa and 82.396 MPa was recorded for the minimum and maximum values respectively for equivalent stress across its structure. Here the center surface of the tube has high value



Figure A.26 Radiography result – steel ball (1320 rpm).



Figure A.27 Radiography result – steel ball (1800 rpm).

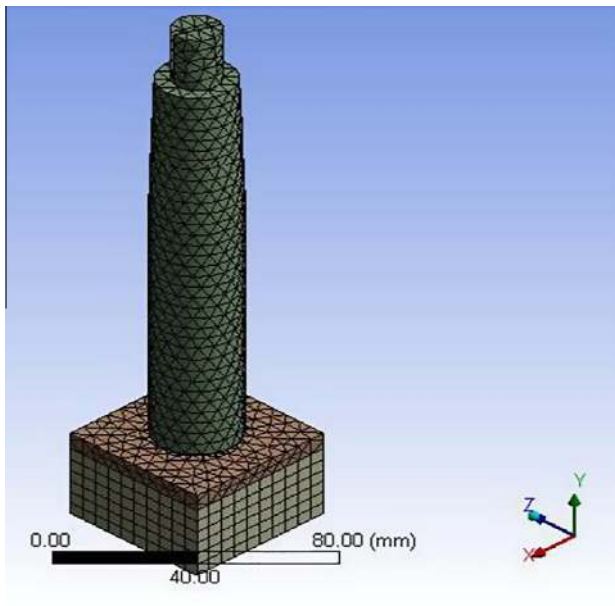

Figure A.28 Fully meshed – tool and the workpiece with steel ball.

of equivalent stress in its surface. Graph 2 shows the variation of effect over the period of the time. Time is measured in seconds in  $x$  axis whereas stress is calculated in MPa in  $Y$  axis.

The analysis recorded equivalent stress value (deformation) implies that more friction effect takes place in the center of the workpiece due to the axial and rotary force acting at the same point. The bonding between the atoms present in the workpiece gets disturbed and there is a possibility of crack and more deformation in and around the center of the workpiece. But when the metal attains its melting temp, the metal flows toward the center of the tool axis, this molten fills the deformation gap present in the workpiece and new bonding between the tube and plate formed possesses a higher joint strength which is mainly due to the flow of metals toward the center of the tool axis.

The overall values recorded due to frictional effect on tube, and tube plate with steel ball have been shown in Table A.6.

### 3.4.2. Workpiece with steel ball – temperature distribution

A thermal analysis calculates the temperature distribution and related thermal quantities in a system or component. Typical thermal quantities of interest are as follows: the temperature distributions, the amount of heat lost or gained – thermal gradients and thermal fluxes. These are caused by a rearrangement of internal energy in the workpiece. The thermal effects are calculated by temperature variation forced on the workpiece from outside or due to internal process [13].

In this analysis, we have calculated the temperature over the tube and plate surface with steel ball as filler material in the workpiece. In Fig. A.31 only tube has been considered for calculating the temperature and it explains the temperature of minimum and maximum values of 1324.3 °C and 1500 °C respectively. In Fig. A.32, only tube plate has been considered for calculating the temperature and it explains the temperature of minimum and maximum values of 1337 °C and 1500.1 °C respectively.

In Fig. A.33, tube, tube plate and the tool with steel ball as filler material have been considered for calculating the temperature and the recorded temperature is about 758.28 °C and 1500.1 °C for minimum and maximum values respectively.

In all the three cases, the temperature distribution was high at the center of the tool and workpiece. The metal gets melted more at the welding zone due to the friction produced by the

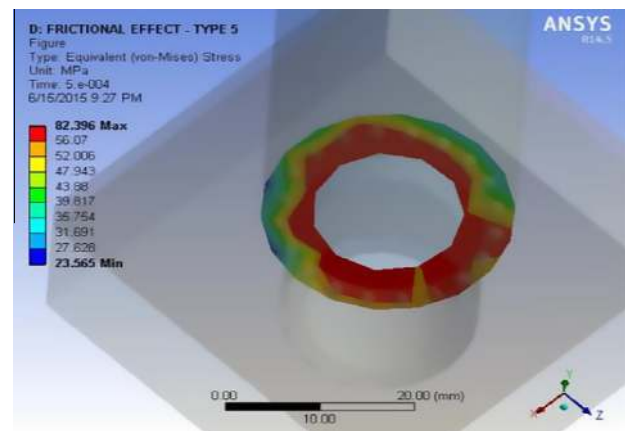
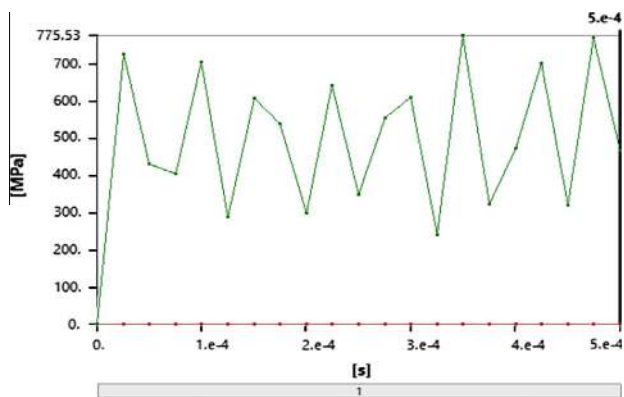

Figure A.29 Stress over the tube.



Graph 1 Variation b/w stress and time.

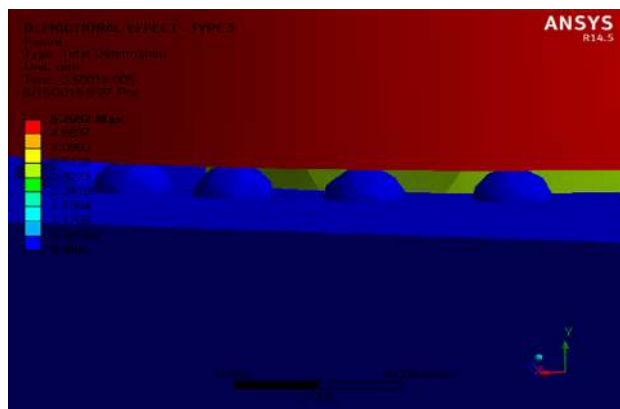
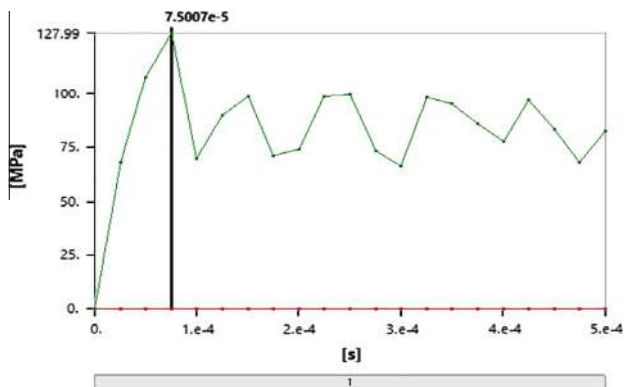

Figure A.30 Stress over the tube plate.



Graph 2 Variation b/w stress and time.

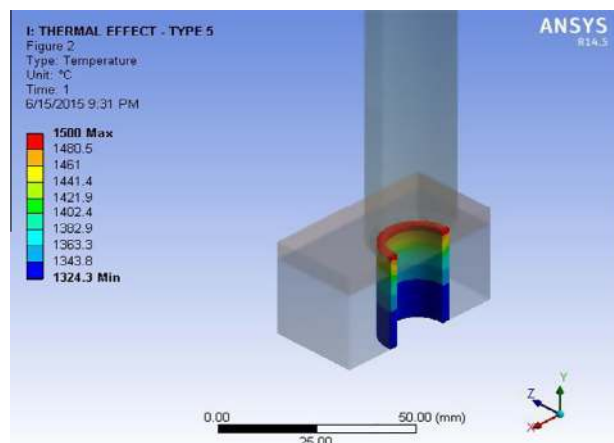

Figure A.31 Temperature distribution around tube.

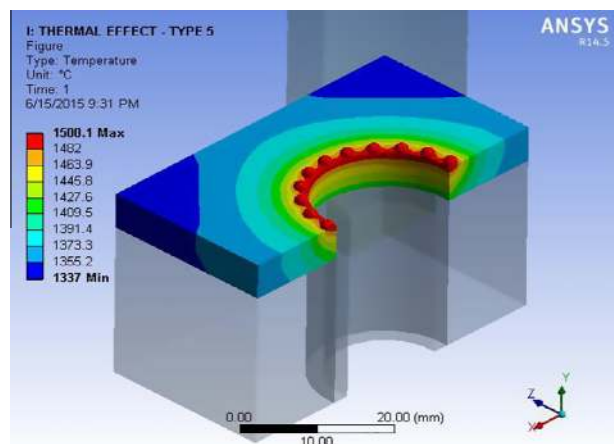

Figure A.32 Temperature distribution around the tube plate.

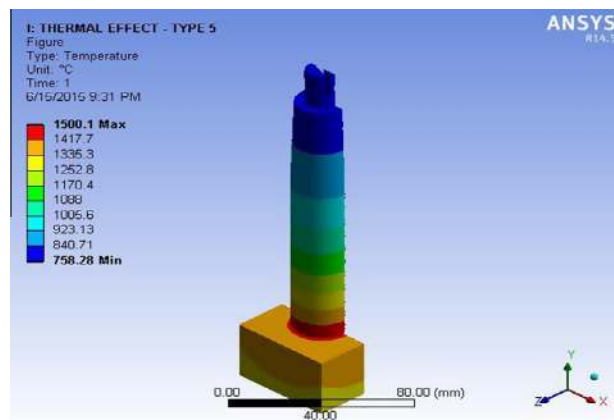

Figure A.33 Temperature distribution in all parts.

Values	Equivalent stress (MPa)	
	Tube	Tube plate
Min	23.565	0
Max	82.396	82.396

tool and the temperature gets reduced when it moves away from the center of the workpiece. The temperature was around 1500 °C in all the cases. Due to high temperature, the metal gets easily melted due to friction and it flows toward the center of the tool and fills the gap made in the hole and it has a high optimal joint strength. The metallurgical bonding between the

**Table A.7** Temperature distribution values due to thermal effect .

Values	Temperature distribution		
	Tube	Tube plate	In all parts
Min	1324.3	1337	758.28
Max	1500	1500.1	1500.1

atoms gets more stabilized due to the filling up of metals at the center of the workpiece.

The overall values recorded due to thermal effect on tube and tube plate with steel ball have been shown in [Table A.7](#).

#### 4. Conclusion

1. The dissimilar metals SA 213 tube and parent material SA 387 tube plate with three filler materials such as filler plate, brass sheet and steel ball have been welded successfully by FWTPET process, which has enormous engineering functions. This friction welding process produced a high quality and defect free weld joint.
2. The microstructure for the three workpiece with filler materials proves the fine grain refinement has been happened in the welding interface and the arrangement of continuous layer at the interface leads to enhanced bonding between the dissimilar metals.
3. The micro hardness values measured for the workpieces are about 240 Hv, 193 Hv and 290 Hv for filler materials such as filler plate, brass sheet and steel ball respectively at the welded interface zone. This hardness value shows that the metal has flow toward the center of the tool axis and gap has been filled with these metals. Hence it forms a better joint between the tube and tube plate.
4. The radiography test conducted for the workpiece with steel ball as filler materials at three different rotational tool speeds confirms that, there is no crack, porosity and other defects. The movement and position of steel ball are clearly seen in the graph that it rotates around the center and the path of tool axis at various speed of the tool.
5. The finite element analysis of both frictional and thermal effect has been conducted for workpiece with steel ball as filler material. It shows that the more deformation has taken place at the center of the tool due to the axial and rotary force of the tool. The thermal effect delivers that, the maximum heat is generated at the center of the tool due to the frictional force at various speeds which makes metal to melt and flow toward the center of the tool axis.
6. From all the results and analysis, the workpiece with filler materials observed the movement of metal flows toward the center of the tool axis and hence, FWTPET process is suitable to make high quality defect free joints.

#### Acknowledgments

The authors like to convey our profound gratitude to the Department of Science and Technology, India, and Financial support release under “Young Scientist Scheme” through Science and Engineering Research Board (SERB) for this research Project, SERB/FTP/ETA/0282-2013.

#### References

- [1] S. Senthil Kumaran, S. Muthukumar, S. Vinodh, Experimental and numerical investigation of weld joints produced by friction welding of tube to tube plate using an external tool, *Int. J. Eng. Sci. Technol.* 2 (5) (2010) 109–117.
- [2] R.L.O. Brien, eighth ed., *Welding Handbook*, vol. 2, American Welding Society, Washington, USA, 1991.
- [3] S. Muthukumar, A process for friction welding tube to a tube sheet or plate by adopting an external tool, Indian patent Application No. 189/KOL/06 filed on 07-03-2006, Patent No. 217446, Granted on 26-03-2008, 2006.
- [4] K. Colligan, Material flow behavior during friction stir welding of aluminum, *Weld. J.* 78 (1999) 229–237.
- [5] S. Senthil Kumaran, S. Muthukumar, Analysis of metal flow behaviour during friction welding of tube to tube plate using an external tool, *Int. J. Manuf. Technol. Ind. Eng. (IJMTIE)* 1 (1) (2011) 79–84.
- [6] S. Senthilkumar, S. Muthukumar, S. Vinodh, Experimental and numerical investigation of weld joints produced by friction welding of tube to tube plate using an external tool, *Int. J. Eng. Sci. Technol.* 2 (2010) 109–117.
- [7] Donald Zipperian, Chemical Etching, *PACE Technol.* 2 (2003) 5.
- [8] SolidWorks, SolidWorks Education, Engineering Design and Technology Series, Dassault Systems – Solid Works Corporation, USA, 2014.
- [9] ANSYS 14.5, Design Modeller and Workbench Meshing, Mark Leddin, ANSYS UK, 2014.
- [10] S. Senthil Kumaran, S. Muthukumar, Analysis of metal flow behavior during friction welding of tube to tube plate using an external tool, *Int. J. Manuf. Technol. Ind. Eng. (IJMTIE)* 1 (2011) 79–84.
- [11] V.L. Popov, *Contact Mechanics and Frictions: Physical Principal and Application*, Springer, London, 2010.
- [12] H. Schmidt, J. Hattel, Modelling heat flow around the tool probe in friction stir welding, *Sci. Technol. Weld. Joining* 10 (2) (2005) 176–186.
- [13] R.F. Speyer, *Thermal Analysis of Materials*, Marcel Dekker, 1994.