

PAPER • OPEN ACCESS

## Design of a Microgrid Architecture for Rental E-Bike Charging Stations

To cite this article: Ghanishtha Bhatti and R Raja Singh 2020 *IOP Conf. Ser.: Mater. Sci. Eng.* **906** 012009

### Recent citations

- [Design and Development of Prototype Model of Advanced Charging System for Energy Efficient Electric Vehicle](#)  
S Kiran *et al*

View the [article online](#) for updates and enhancements.



**ECS** **240th ECS Meeting**  
Oct 10-14, 2021, Orlando, Florida

**Register early and save  
up to 20% on registration costs**

Early registration deadline Sep 13

**REGISTER NOW**

# Design of a Microgrid Architecture for Rental E-Bike Charging Stations

**Ghanishtha Bhatti, R Raja Singh**

Department of Energy and Power Electronics,  
School of Electrical Engineering, VIT Vellore.

Correspondence email: rrajasingh@gmail.com

**Abstract.** This paper focuses on developing a sustainable charging station for public motorbike rental services. Electric motorbikes or electric bicycles (both referred to as E-bike) are compact electric vehicles which are primarily battery powered and driven solely by electric motors. The work proposes a microgrid architecture to develop a novel model for the rental E-bike charging station that acts as a charger for multiple nodes simultaneously as well as acting as a docking/parking station for these vehicles. The model has been built to propose a system which increases the energy savings to rental companies while reducing reliance on public grid during peak hours. The use of distributed generation makes the system more resistant to failure while moving towards a future of eco-friendly and power efficient technology.

## 1. Introduction

The decline in non-renewable resources such as crude oil has become so significant, that the transition to sustainable energy has become a priority for law and policy makers. This has led to the research and development of renewable technology such as distributed generation (DG). However direct transition to fully DG supplied PEVs is not yet viable due to cost and power regulation constraints to prevent mismatches with the load. To bridge this gap, the concept of microgrids combines the conventional grid based supply, renewable DG energy and storage technology to actively regulate and maintain balance in the system [1]. Microgrids provide a reliable and efficient alternative architecture to increase the small scale renewable energy penetration while minimizing the energy cost [1-3], predominantly in case of urban areas.

Plug-in electric vehicles are predicted to become an integral part of the vehicle market in future years, and represent mankind's leap towards achieving low-carbon automobiles. Currently a notable amount of automobile manufacturers produce plug-in electric vehicles (PEV), either battery based electric vehicles or hybrid electric vehicles. It is also forecasted that during the next few years almost all major automotive manufacturers will introduce PEV models [1]. While the average consumer is skeptical about shifting to electric vehicles, the shift provides many consumer benefits such as lower fuel costs, and lower need of maintenance, because the average electric vehicle has around one tenth the moving parts that a conventional vehicle does. Policy has also affected the consumer outlook towards electric vehicles, and many public communities provide added perks such free parking, discounted insurance and other purchasing incentives to promote lowering vehicular carbon footprint. Although PEVs have various merits, they do place a substantial load on the real-time power supply. PEVs draw large amount of current when charging, which may have a detrimental effect on the public grid.



Microgrid architectures pose potential for innovation, therefore a multitude of academic study has delved into utilizing them for optimizing PEV infrastructure. A charging station model is presented in [13] that allows fast charging (25 kWh per hour at peak) using a bidirectional AC/DC converter. One of the more popular methodology is using solar energy for PEV charging stations [4-6], however most of these models fail to propose a feasible design for the market. Another aspect of increasing energy savings and efficiency is selling energy back to the grid with models such as vehicle to grid strategy (V2G) [7]. This model combined with energy management algorithms such as day ahead scheduling, ensures long term profits. A similar technique that benefits from using the excess energy during vehicle charging is shown in [8]. Coming to more integrated approaches, [9] proposes a novel architecture for grid connected charging stations that includes PV supply as well. This model has also taken the advantage real-time energy management algorithm that continuously uses feedback to reduce errors. For more complex loads, such as entire buildings, a different layered approach which requires multiple agents is needed, such as the one proposed in [10]. The research in [13] showcases a building integrated DC microgrid which utilizes several different renewable energies and present a visionary construction for residences of the future. Many studies focus on controlling the charging parameters of PEVs at peak times to reduce stress on the grid such as [11], though these works lack in description of the system when the grid power is disconnected. The study brings light upon the DC/DC boost converter which allows compatibility with the DC link. The most popular battery technology in PEVs is Lithium-Ion batteries. However, proposals for unconventional media such as superconducting magnetic energy [12] present scope for greater optimization. A DC bus has been used to integrate all these components and the interface is again made possible by power electronic converters.

While a lot of the focus with PEV is towards electric cars, another growing area of popularity is electric two wheel vehicles such as E-bikes and E-scooters. Two wheelers gain popularity as the traffic congestion in metropolitan cities increases, as well as with the advent of narrower road and lesser parking space. In India amongst the 26.27 million vehicles sold in 2019, 80% were two wheelers [14]. Furthermore in recent years there has been increasing popularity amongst app based bike rentals for commuting rather than purchase of a personal vehicle. There were also notably 1.56 lakh new units of EVs (excluding E-rickshaws) purchased in 2019, the majority of which were electric two wheelers. A study into academia shows some novel configuration for charging electric two wheelers. Wireless energy transfer using field effect transistors, proposed in [15], is shown to be a viable charging strategy for motorcycles in remote locations. Other contemporary work such as [16] show potential for reimagining electric two wheelers as a new class of hybrid electric vehicles allowing a varied supply of energy from both conventional and renewable sources. The logic controller design for an E-bike charging station proposed in [17] provides potential for more secure usage of public charging stations, even though the RFID framework suggested is less reliable for security purposes.

This work aims to contribute to this developing field by proposing a microgrid based electric motorcycle/bike charging station. This model aims at utilization by rental services to offer a chargeable commute service via electric bikes with solar energy based charging and docking station simulation. The utility of charging an array of rental vehicles simultaneously as they park offers a substantial cost saved on fuel as well as a significant reduction in greenhouse gas emissions. These features make the contribution of this paper novel. The remainder of this paper is organized as follows. Section 2 presents the microgrid architecture of the proposed charging station, considering the real-world constraints and trends. Section 3 provides a mathematical conceptual understanding of the electrical systems involved. It also details the use of photovoltaic arrays to harness energy. Section 4 introduces the input data of the simulation and evaluates the parameters observed when modelling a microgrid for this application. Section 5 illustrates the obtained simulation results when performed with MATLAB Simulink and evaluates the model with these results. Section 6 concludes and summarizes the novelty and contributions of the proposed framework.

## 2. System Description

The proposed system is based on a DC microgrid. As show in Figure 1, the microgrid is energized from a 6 kW local solar array, 30 kW solar farm as well as connection to the public grid. All these components are centrally DC converted and linked to the charging station which facilitates battery charging for EVs. Rather than using a grid reliant model for the charging station which is the more commercially utilized, a microgrid approach is suggested. The microgrid approach helps to create a low cost, efficient and locally resilient system that reduces the load on the public grid, an imminent concern in cosmopolitan cities at peak hours. Furthermore it ensures that the system has contingency in case of power failure or unexpected electrical faults to the main grid. The reliability boosts the operational capability for the rental agency as well as improved and uninterrupted service to the end user. The demotion of the public grid as a backup to this system rather than the primary source also invokes the possibility to sell excess energy. This kind of architecture is known as Vehicle to Grid model (V2G), however this work has not extended to V2G for the purposes of this paper. Microgrids operate in various modes which make their operation flexible. There are two major modes considered for modelling the microgrid architecture [18].

- **Hybrid Mode**

The breaking mechanism is closed to connect to the utility grid. The utility grid equips all the feeders and the distributed generation based microgrid provides some surplus power to the main grid.

- **Islanding Mode**

The grid breaker is opened in case of electric faults thus preventing the utility grid from providing power. Microgrid can operate independently preventing power outage to load when the utility grid is not usable.

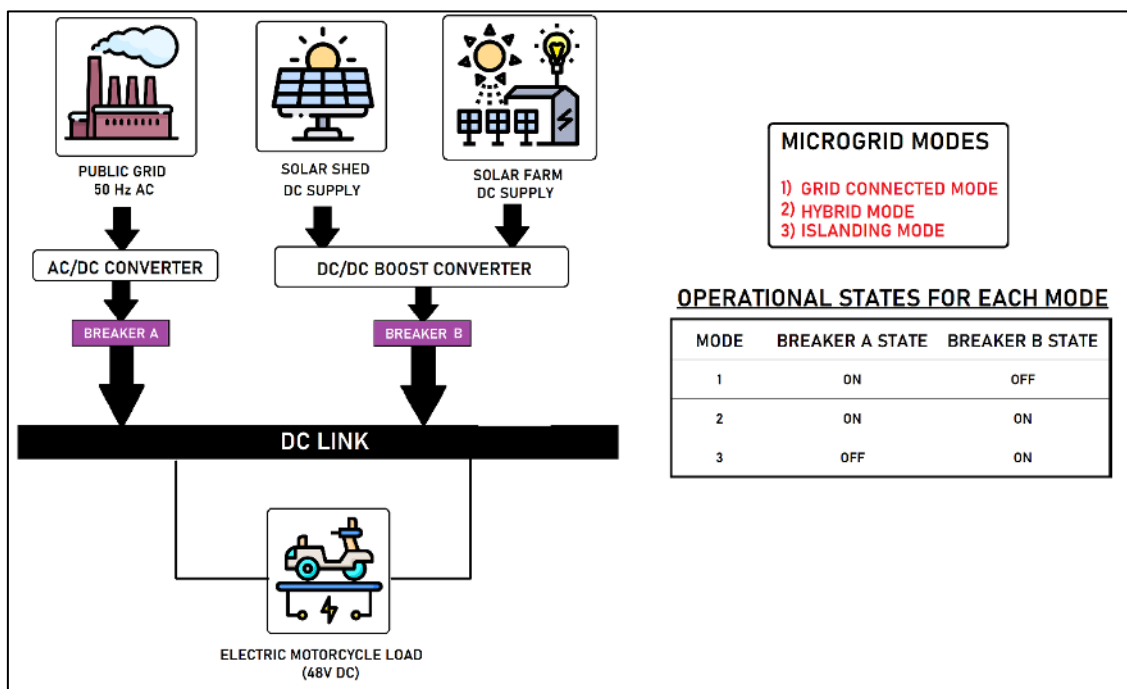
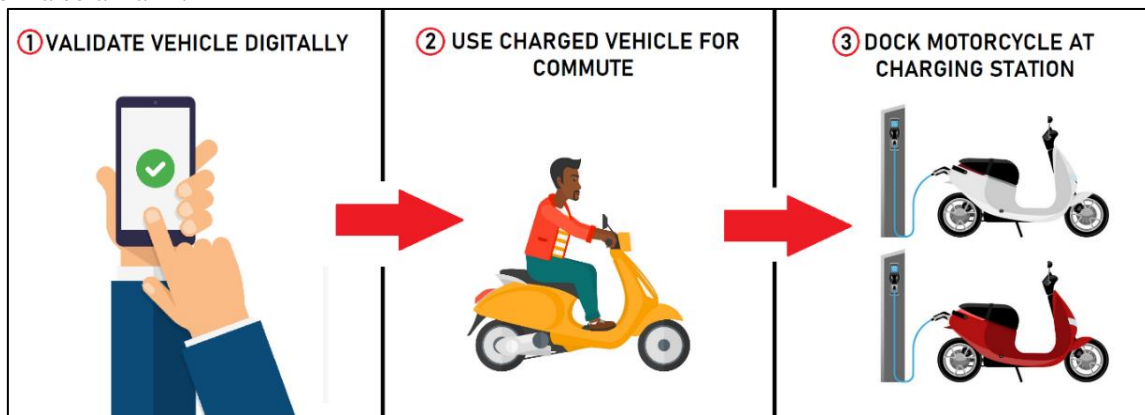

**Figure 1.** Microgrid Architecture

As part of this study both these modes have been modelled in this work, in order to ensure the feasibility of the model when prototyped. Furthermore for the purpose of comparative analysis the model has also been run in grid connected mode (Public Grid only) as shown in Figure 1. Solar Energy is considered as the distributed resource for this model as it represents the following features which are optimal for this application and the environment:

1. Solar energy is theoretically unlimited
2. Higher power density than most conventional renewable resources
3. It is a non-polluting resource and does not aid greenhouse effect.
4. It is suitable for both high and low power devices
5. Solar energy is free (excluding the harvesting equipment). Over the years the energy and cost savings exceed fuel or grid power for vehicles.
6. PV systems are low maintenance and have long life.
7. Do not occupy much ground space as they may be pole-mounted
8. Can be used in residential areas as they do not produce noise or hindrance for civilians.
9. Can harvest energy in most open areas at a significant rate
10. Largest market in India among renewable resources

The model of commercial usage of the system prototype based on this architecture is illustrated in Figure 2. The user simply rents the electric motor bike for a period using a digital authorization such as a smartphone app. Once they have used the bike or want to charge it they may simply return it to the dockings station which detects completion of the users purchase and also charges the motorbike for next use. Overall this model incurs great benefits to the rental service as costs of fuelling the electric vehicles is greatly reduced, and the system requires minimum intervention by human employees, which reduces labour cost as well. The produced PV electricity is intended as the primary source for charging of Electric bikes. The two separate PV arrays are located in different geographical areas for maximizing reliability and availability of solar energy to the system. The first array is placed on a shed mounted over the electric motorbike docking area which acts as a shade to prevent vehicle heating while also harvesting energy with low transmission loss. To prevent the possibility of system failure in case of low local irradiance, another solar array is used as a power source which is routed from a solar farm.



**Figure 2.** Prototype Application Model.

### 3. Mathematical Modelling of PV powered E-bike charging station

To be able to successfully build this architecture, the mathematical models that govern the constituent input component, such as the photovoltaic array and power electronic converters must be determined. On the output side, to simulate the charging of the EVs (Electric bikes) they are modelled as batteries whose parameters must be computed. Their charging equations such as voltage behaviours and battery state of charge (SOC) need also be determined to evaluate the model performance.

#### 3.1. Photovoltaic Array

Solar power has been determined in the model using input of irradiance (beam and diffuse radiation included) as well as ambient temperature. In order to calculate the solar radiation absorbed on the cell surface,  $S$ , it is mandatory to measure incident radiation, air mass, and incidence angle. With these parameter it is possible calculate solar power ( $S$ ) using Equation 1.

$$S = M(G_b R_b (\tau\alpha)_b + G_d (\tau\alpha)_d \frac{1 + \cos \beta}{2} + G_{\rho g} (\tau\alpha)_g \frac{1 + \cos \beta}{2}) \quad (1)$$

Here  $M$  is the air mass modifier,  $\tau\alpha$  the fraction absorbed by an absorber plate.  $G$  gives the radiation (the subscript indicates whether the radiation is beam (b), diffuse (d) or ground ( $\rho g$ )).  $\beta$  is the Angstrom turbidity coefficient and  $R_b$  the ratio of beam radiation on the plane to that on a horizontal surface at any time. The solar power  $S$  is measured in  $W/m^2$ .

The other factor affecting the modelling and output of PV arrays is temperature. While it might be thought that heat increases the amount of solar energy received by solar cell, the solar energy that can be harvested is dependent on the irradiance. However, this does not imply that heat or temperature does not affect temperature. Efficiency  $\eta_s$  of the solar cell given in Equation 2, will highlight this relationship. Here  $I_{max}$  represents maximum current and  $V_{max}$  indicates the maximum voltage.

$$\eta_s = \frac{(I_{max} \times V_{max})}{P_{in}} \quad (2)$$

When the temperature increases, the current will increase, while the voltage will decrease. As the voltage decreases faster than the current increases, the overall efficiency is decreased. Therefore, the power output can be presented as a function shown in Equation 3.

$$P = P(S, T_{mod}) \quad (3)$$

Here  $T_{mod}$  represents the temperature of module given by the relation in Equation 4. The parameter  $k_T$  defines the clearness index of the location.  $T_{air}$  represents the temperature of air and  $G$  represents total incident radiation.

$$T_{mod} = T_{air} + k_T G \quad (4)$$

The power output of the cell ( $P$ ) can be calculated using Equation 5.  $P_{nom}$  is the peak power, in kWh.

$$P = \frac{P_{nom} \times S}{1000} \quad (5)$$

### 3.2. Power Electronic Converters for the Microgrid

DC-DC converters are essential to photovoltaic array based systems when connecting them to loads or grid. Converters allow manipulation of the output voltage to meet the required the levels of the load or the grid. In consideration with function of this model a boost converter is required in conjunction to each PV array in order to step up the voltage to the required level of the EV load. The parameters required to compute the power stages and component specifications are as follows [19]:

1.  $V_{OUT}$ : nominal output voltage
2.  $V_{IN(min-max)}$ : the input voltage range
3.  $I_{OUT(max)}$ : maximum output current
4.  $F_s$ : minimum switching frequency of the converter

In order to determine the value of the inductance, the duty cycle ( $D$ ) of the converter must be calculated using Equation 6 where  $\eta_c$  represents the efficiency of the converter.

(6)

$$D = 1 - \frac{V_{IN(\min)} \times \eta c}{V_{OUT}}$$

The switching current, which is determined by the duty cycle, drives the operation of the switch which is commonly an IGBT or MOSFET. This switching current calculation is detailed in Equation 7.

$$I_{SWmax} = \frac{\Delta I_L}{2} + \frac{I_{OUTmax}}{1 - D} \quad (7)$$

$\Delta I_L$  represents inductor ripple current. With these parameters it is possible to calculate the inductance (L) using Equation 8.

$$L = \frac{V_{IN} \times (V_{OUT} - V_{IN})}{\Delta I_L \times F_s \times V_{OUT}} \quad (8)$$

Similarly, the input capacitor value is determined from the data sheet. The value is kept at minimum so that the input voltage is stabilized for the switching power supply. In the case of the output capacitor, it is used to achieve the required level of output ripple voltage. Equation 9 allows computation of this capacitance [19].

$$C_{OUT} = \frac{I_{OUTmax} \times D}{F_s \times \Delta V_{OUT}} \quad (9)$$

### 3.3. Electrical Vehicle Modelling

For the purposes of this work, the primary interest lies in the charging behaviors of the electrical vehicle or more specifically the electric motorbike. This is why we may model solely the battery subsystem of the automobile. While considering the battery the most important aspect is to select the required battery chemistry. In the case of most EVs, lithium ion batteries are used and the same battery chemistry will be utilized for the purpose of this paper.

Lithium ion batteries are selected because they have the highest coulombic efficiency (CE) values compared to alternate rechargeable batteries (> 99%). CE refers to the efficiency of charge at which electrons are transported in batteries and refers to the ratio of the total charge obtained from the battery to the total charge given to the battery during a full cycle [20]. The usable battery capacity is characterized by SOC of battery defined as the ratio of remaining capacity to fully charged capacity shown in Equation 10.

$$SOC = \frac{Q - Q_{min}}{Q_{max} - Q_{min}} \quad (10)$$

In the above equation Q is the charge currently stored,  $Q_{min}$  is the charge that remains in the battery when minimum voltage (open circuit) is reached and  $Q_{max}$  is the charge at maximum open circuit voltage. For aiding modelling the SOC must be defined, as given in Equation 11.

$$SOC = SOC_0 - \frac{1}{SOC_0} \int i \, dt. \quad (11)$$

$SOC_0$  is the initial SOC level of battery and  $i$  is the battery current. To get a more comprehensive estimation of SOC, a few additional parameters must be considered. Firstly the voltages based SOC ( $SOC_v$ ) given by Equation 12.

$$SOC_v = \frac{1}{a_1} (V_{oc} - a_0) \quad (12)$$

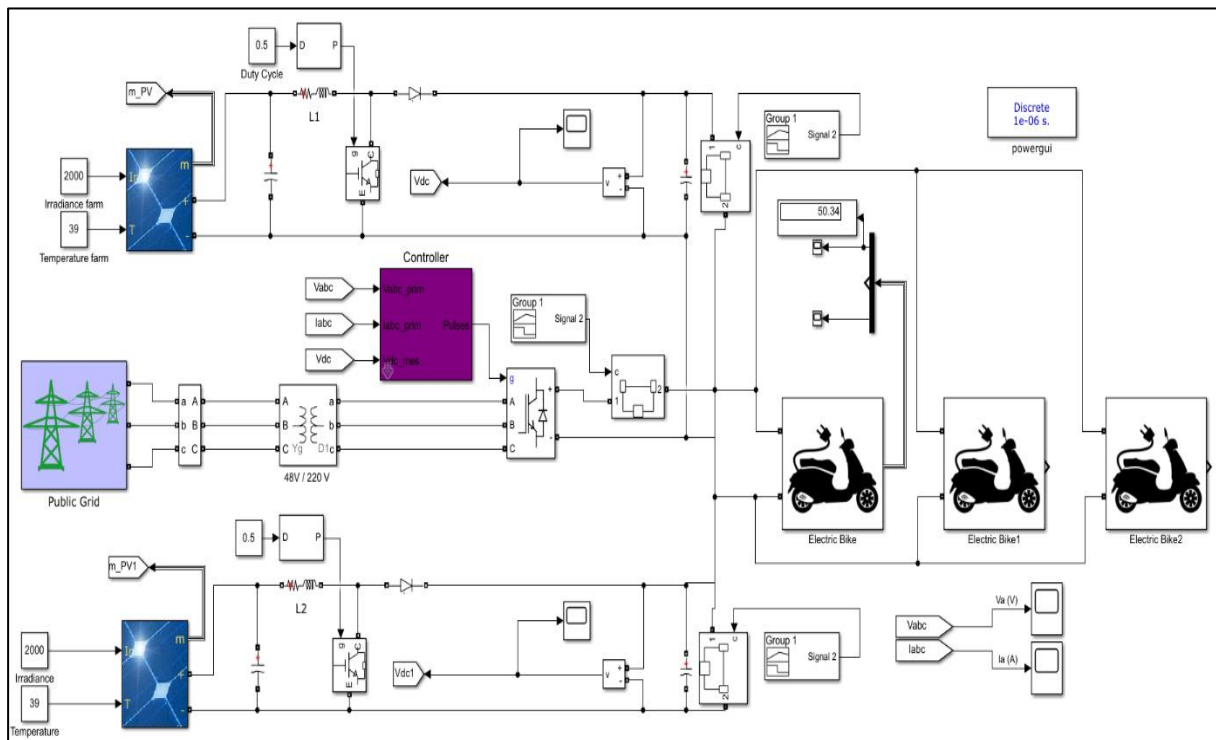

**Figure 3.** Microgrid Simulation Diagram

$V_{OC}$  defines temperature dependent open circuit voltage,  $a_0$  is terminal voltage at 0% SOC, and  $a_1$  represents the terminal voltage at 100% SOC. On the other hand current based SOC ( $SOC_i$ ) which is determined by the Coulomb Counting method (Equation 13). Here  $C_p$  represents the battery capacity.

$$SOC_i = \frac{1}{C_p} (C_p - \int i dt) \tag{13}$$

A systematic correction factor ( $\eta$ ) is also required and is a function of initial SOC level. The equation that corrects the discharging profile values is given in Equation 14.

$$\eta = \left(1 - \frac{SOC_0}{100}\right) \tag{14}$$

Finally, using these parameters the modified equation for SOC can be obtained as shown in Equation 15. Here  $w$  is an additional weighting factor.

$$SOC = w \times SOC_v + (1 - w)(SOC_i - \eta) \tag{15}$$

#### 4. Implementation of the Proposed E-Bike Charging System

The proposed microgrid framework has been modelled in MATLAB Simulink with the advanced and customizable blocksets. The complete simulation model, shown in Figure 3, consists of dual PV arrays, power electronic converters, the public grid and electric motorbike loads to simulate the charging behavior. These subsystems are categorized by their parameters which customize the function of this architecture towards the application of a multiport charging station.



#### 4.1. PV System Parameters

Physical considerations that entail the sizing of the PV system are the irradiance and temperature models. The temperature and irradiance datapoints have been modelled based on conditions in Vellore, Tamil Nadu during the month of April. The average global horizontal irradiance is 2000 W/m<sup>2</sup> as per data from Meteonorm [21] and the mean temperature is considered as 39°C. Indian market models have been considered while modelling the PV array to ensure compatibility with the Indian Grid System. The dual PV cell is modelled closely in specification with SunPower SPR-305E-WHT-D. The array to be utilized locally (at the charging station) has 10 parallel strings of solar cells with each string consisting of 2 series connected cells. The second array is modelled to resemble a solar farm for larger fault tolerance to the system. This array consists of 50 parallel strings with 2 series connected solar cells in each string.

#### 4.2. Public Grid Parameters

A standard three-phase source models the public grid at 220V and 230,000 MVA [22] operating at 50Hz. The public grid connection is carried out by a three-phase AC/DC converter. A simple voltage source controller mechanism accompanies the grid converter for feedback based regulation of output voltage [23].

#### 4.3. Power Electronic Converter Parameters

Two major circuits have been used as part of this model for power electronic conversion.

- 11. Three-phase AC/DC converter:** The role of a converter in the microgrid is to operate as an interface between energy generation and consumption points. An IGBT circuit is used with this purpose. The driving gate pulse of the converter is provided by a VSC controller which acts as a regulator by taking feedback from the grid voltage and current as well as the DC output voltage of PV array.

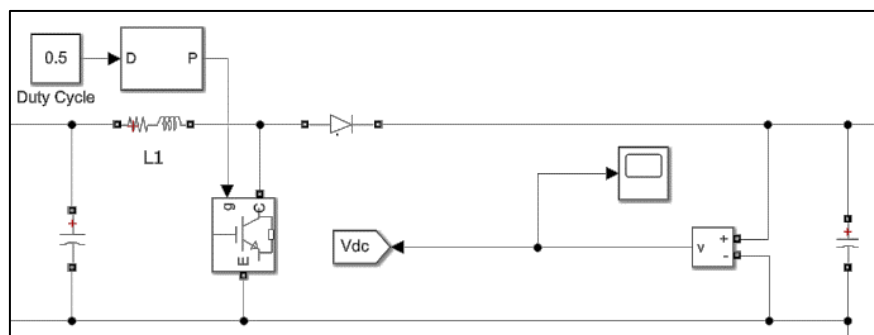

**Figure 4.** DC/DC Boost Converter Circuit

- 12. DC/DC Boost Converter (Figure 4):** This has been used to regulate the voltage level from the PV source to the required output level of the Electric bike load. The switching frequency (duty cycle) has fixed at the minimal achievable value of 0.5. Without any tracking or MPPT this is the standard testing value. The specifications of the converter are detailed in Table 1.

**Table 1.** DC/DC Boost Converter Parameters

Sl. No	Parameter	Value
1	Input Capacitance	0.1 mF
2	Inductance	5 mH
3	Duty Cycle of Switching	0.5
4	Output Capacitance	12 mF

#### 4.4. Model Modes and Autonomous Switching

In order to evaluate the feasibility of the microgrid architecture the model switches between different modes during simulation which entail various energy source combinations. The modes are as follows:

- **Grid Connected Mode:** Standard architecture for PEV charging, through direct connection to the public grid. This mode is the control for testing the performance of the microgrid.
- **Hybrid Mode:** The ideal functioning mode for the microgrid which utilizes power from both the AC public grid as well as two separate DG sources (in this case PV arrays).
- **Islanding Mode:** In case a fault or failure of the public grid occurs, the microgrid islands itself and supplies power independently from the DG source to the load.

In order to switch the model between various modes in case of a fault, the grid circuit is built with breaker mechanisms that islands the charging station from the grid. The circuit breakers are controlled by the proposed algorithm.

#### 4.5. E-bike Battery system parameters

The load is considered to be conventional electric bike of economic class that are most commonly utilized in the Indian market such as the Vespa Elettrica™. The battery technology employed is Lithium Ion batteries which are commonly used in the market. For simulation the Simulink battery blockset [24] has been utilized along with experimental and commercial customization. The aging and temperature effects on the battery have not been developed as part of this study. The specifications have also been modelled from commercial vehicles as shown in Table 2.

**Table 2.** Electric Bike Model Parameters

Sl.No	Parameter	Value
1	Nominal Battery Voltage	48 V
2	Battery Capacity	86 Ah
3	Battery Energy	4.2 kW/h
4	Forecasted Battery Life	1,000 cycles
5	Optimal Charging Time	4 hours
6	Initial Battery SOC	50 %

## 5. Results and Discussion

To validate the DC microgrid for PEVs charging station modeling approach, the system simulation is performed with MATLAB Simulink. The simulation is developed to model the E-bike charging station under as a standalone microgrid in islanding mode and hybrid mode.

The simulation has a run time of 3s and the battery response time has been lowered to produce quantifiable changes in SOC without expending limited computational resources for the purposes of proof of concept. Furthermore, to optimize the simulation with regards to processing power, it has been run on the Simulink Accelerator mode using the Just-in-time algorithm. In this workflow model Simulink generates for the top-level model only an execution engine in memory excluding the referenced models. Therefore, the inherent C compiler is not used during run-time, increasing execution speed and reducing processing required. The charging profile of the implemented system is shown in Figure 5.

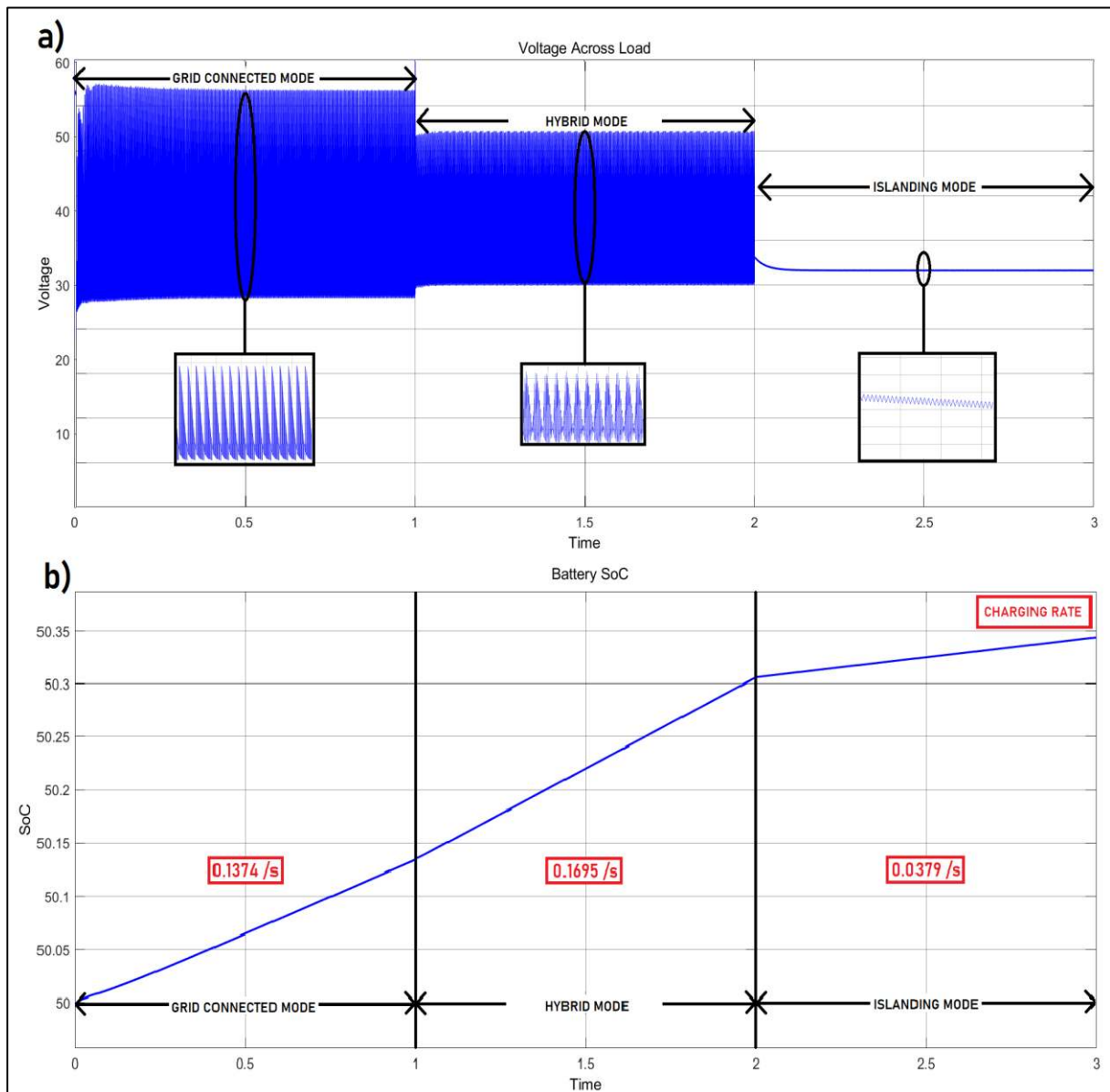

**Figure 5.** Charging Profile in various modes a) Load Voltage, b) Battery SOC

### 5.1. Grid Connected Mode

This mode shows the standard model of operation for PEV charging. It has a calculated charging rate of 0.1374% per second in the response accelerated model. Furthermore a ripple in the output voltage at the load end is observed fluctuating between the limits of 27.721 to 56.224 V. This ripple is likely present due to incomplete suppression of the AC waveform after rectification. While the value of ripple in the circuit is minimal, it represents lost power and decreased efficiency. It may be amended in the future by introducing electronic filters or improved regulator at the output level to suppress the ripple. This regulation may also be achieved using ripple suppressing devices such as capacitors.

### 5.2. Hybrid Mode

This mode introduces the microgrid architecture in place. Predictably, the rate of SOC growth increases to 0.1695 % per second with the injection of two DC PV arrays as sources. This injection also considerably lowers the output ripple between 30.156 and 52.589.

### 5.3. Islanding Mode

The microgrid islanding that comes into utilization during faults is presented in this mode. The rate of charging is observed to be 0.0379 % per second. While this represents a drop of 0.1316 % per second, we can observe that the renewable distributed generation framework is able to supply the necessary energy to support the system without requiring the system to be taken offline. This supports the feasibility of this model as a prototype as well as demonstrates the efficiency and reliability of the microgrid architecture for the electric motorbike charging stations. It can also be observed that there is a reduction in output ripple voltage which is due to disconnecting the major AC source from the microgrid. The output ripple is between the limits 31.144 and 32.045 V.

## 6. Conclusion

Shifting from conventional, polluting and depleting resources has become crucial as we progress into an age where these resources have become increasingly scarce. Electric Vehicles play a major role in this shift. The consumer market grows towards adopting electric vehicles especially more pocket-friendly alternatives such as electric motorcycles and scooters because of the savings they offer. While most countries have a rapidly growing market for electric vehicles, the infrastructure for maintaining them is still limited. Charging stations, especially in India, are extremely rare, which poses a barrier to expanding the electric motorcycle market. In order to propose a charging infrastructure which is both feasible and easy to implement this study proposes a microgrid model to support the increasingly popular bike rental business. The use of distributed generation allows renewable energy to be integrated into the charging system and the microgrid concept that facilitates islanding allows for reducing load on the conventional grid.

The developed simulation model in this study was evaluated with respect to the ideal load of a Vehicle Lithium Ion Battery and its power, voltage and current parameters were verified to be sufficient to charge such a load. The model has been developed as a proof of concept and does not venture into intricacies of vehicle dynamics, battery capacities or cost benefit analysis. Introducing these elements form the future scope of this elements and hold the possibility of optimization of the power flow and conversion.

## 7. References

- [1] Locment F and Sechilariu M 2015 Modeling and simulation of dc microgrids for electric vehicle charging stations. *Energies* vol 8 pp 4335-4356
- [2] Manna D and Goswami S 2017 Micro-grid operation and control *National Conference on Recent Trends in Engineering and Technology (NCRTE-2017) Tripura (W), India* Vol: ISBN: 978-93-87380-61-5
- [3] Patterson B T 2012 Dc, come home: dc microgrids and the birth of the "enernet" *IEEE Power and Energy Magazine* vol 10 no. 6 pp 60-69
- [4] Corchero C, Cruz-Zambrano M, Heredia F.-J, Cairo J.-I, Igualada-Gonzalez L and Romero-Ortega A 2012 Optimal sizing of microgrids: a fast charging station case *2012 9th International Conf. on the European Energy Market* pp 1-6
- [5] Guo Y, Xiong J, Xu S and Su W 2016 Two-stage economic operation of microgrid-like electric vehicle parking deck *IEEE Transactions on Smart Grid* vol 7 no. 3 pp 1703-1712
- [6] Mouli C, Ram G, Bauer P and Zeman M 2016 System design for a solar powered electric vehicle charging station for workplaces *Applied Energy* vol 168 pp 434-443
- [7] Armstrong M, Moussa C, Adnot J, Galli A and Rivière P 2012 Optimal recharging strategy for battery-switch stations for electric vehicles in france *Energy Policy* vol 60
- [8] Van Roy J, Leemput N, Geth F, Büscher J, Salenbien R and Driesen J 2014 Electric vehicle charging in an office building microgrid with distributed energy resources *IEEE Transactions on Sustainable Energy* vol 5 no. 4 pp 1389-1396

- [9] Mohamed A, Salehi V, Ma T and Mohammed O 2014 Real-time energy management algorithm for plug-in hybrid electric vehicle charging parks involving sustainable energy *IEEE Transactions on Sustainable Energy* vol 5 no. 2 pp 577-586
- [10] Wang Z, Wang L, Dounis A and Yang R 2012 Integration of plug-in hybrid electric vehicles into energy and comfort management for smart building. *Energy and Buildings* vol 47 pp 260–266
- [11] Goli P and Shireen W 2014 Pv integrated smart charging of phev's based on dc link voltage sensing *IEEE Transactions on Smart Grid* vol 5 no. 3 pp 1421-1428
- [12] Liu Y, Tang Y, Shi J, Shi X, Deng J and Gong K 2015 Application of small-sized smes in an ev charging station with dc bus and pv system *IEEE Transactions on Applied Superconductivity* vol 25 no. 3 pp 1-6 Art no. 5700406
- [13] Strunz K, Abbasi E and Huu D N 2014 Dc microgrid for wind and solar power integration *IEEE Journal of Emerging and Selected Topics in Power Electronics* vol 2 no. 1 pp 115-126
- [14] Indian Automobile Industry Report 2020 Copyright © 2010-2020 India Brand Equity Foundation
- [15] Widjanarka W and Sutiyatno S 2020 Experiment electrical motorcycle used solar energy with wireless transfer energy method for transportation in isolated regions *Journal of Physics: Conference Series* vol 1517 pp 012098.
- [16] Wu and Xu 2019 The optimal control of fuel consumption for a heavy-duty motorcycle with three power sources using hardware-in-the-loop simulation *Energies* vol 13 pp 22
- [17] Inácio C, Silva I, Faria J, Pombo J, Calado M and Mariano S 2020 Controller design and experimental validation of a solar powered e-bike charging station *KnE Engineering International Congress on Engineering — Engineering for Evolution* pp 846-856
- [18] Prakash M M and Paul J 2016 Control of microgrid for different modes of operation *International Journal of Engineering Research & Technology (IJERT)* vol 05 issue 05
- [19] Hauke B 2014 Basic calculation of a boost converter's power stage *Texas Instruments Inc SLVA372C*
- [20] Miao Y, Hynan P, Jouanne A V and Yokochi A 2019 Current li-ion battery technologies in electric vehicles and opportunities for advancements *Energies* vol 12
- [21] TANGEDCO 2020 Solar irradiance data in tamil nadu Retrieved from <https://www.tangedco.gov.in/linkpdf/solar%20irradiance%20data%20in%20Tamil%20Nadu.pdf>
- [22] Chowdhury T 2015 Design of a micro-grid system in matlab/simulink *International Journal of Innovative Research in Science, Engineering and Technology* vol 04 pp 5262-5269
- [23] Abootorabi M 2020 power\_PVarray\_grid\_det *MATLAB Central File Exchange* retrieved May 2020 ([https://www.mathworks.com/matlabcentral/fileexchange/52434-power\\_pvarray\\_grid\\_det](https://www.mathworks.com/matlabcentral/fileexchange/52434-power_pvarray_grid_det))
- [24] Kuperman A, Levy U, Goren J, Zafransky A, and Savernin A 2013 Battery charger for electric vehicle traction battery switch station *IEEE Transactions on Industrial Electronics* vol. 60, no. 12, pp. 5391-5399.
- [25] Piaggio & C 2018 Vespa Elettrica Retrieved from [https://elettrica.vespa.com/\\_common/pdf/EN-DIGITAL-VespaElettrica-10-2018.pdf](https://elettrica.vespa.com/_common/pdf/EN-DIGITAL-VespaElettrica-10-2018.pdf)

### Acknowledgments

We would extend our gratitude to the faculty members and staff members at Vellore Institute of Technology with whose support we were able to procure the necessary software resources to develop our model and run analysis on it.