

PAPER • OPEN ACCESS

Design of An Energy Efficient Hydraulic Regenerative circuit

To cite this article: S Ramesh *et al* 2018 *IOP Conf. Ser.: Mater. Sci. Eng.* **310** 012042

View the [article online](#) for updates and enhancements.

Design of An Energy Efficient Hydraulic Regenerative circuit

Ramesh.S^{1*}, S. Denis Ashok², Shanmukha Nagaraj³, Adithyakumar. C.R¹, M. Lohith Kumar Reddy¹, Niranjan Kumar Naulakha¹.

¹ Department of Mechanical Engineering, SET, Jain University, Bengaluru, India.

² Department of Design and Automation, SMEC, VIT University, Vellore, India.

³ Department of Mechanical Engineering, R V College of Engineering, Bengaluru, India.

*E-Mail: shankaranarayanaramesh@gmail.com

Abstract. Increasing cost and power demand, leads to evaluation of new method to increase through productivity and help to solve the power demands. Many researchers have break through to increase the efficiency of a hydraulic power pack, one of the promising methods is the concept of regenerative. The objective of this research work is to increase the efficiency of a hydraulic circuit by introducing a concept of regenerative circuit. A Regenerative circuit is a system that is used to speed up the extension stroke of the double acting single rod hydraulic cylinder. The output is connected to the input in the directional control valve. By this concept, increase in velocity of the piston and decrease the cycle time. For the research, a basic hydraulic circuit and a regenerative circuit are designated and compared both with their results. The analysis was based on their time taken for extension and retraction of the piston. From the detailed analysis of both the hydraulic circuits, it is found that the efficiency by introducing hydraulic regenerative circuit increased by is 5.3%. The obtained results conclude that, implementing hydraulic regenerative circuit in a hydraulic power pack decreases power consumption, reduces cycle time and increases productivity in a longer run.

Keywords: Regenerative, Hydraulic circuit, Energy efficiency, Cycle time, Piston velocity

1. Introduction

A Regenerative circuit is used to speed up the extension stroke of a double-acting single rod cylinder. Allowing fluid to flow into both the ports of a single rod cylinder to make it expand or at least try to expand as areas of contradictory sides of the piston are inadequate, the piston end of the cylinder has more force than the rod side.

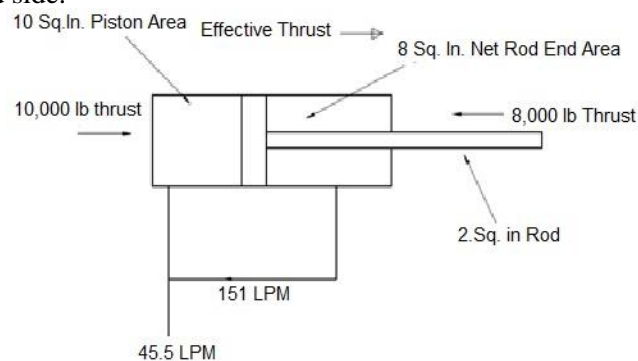

Figure. 1 Cylinder having a small-diameter rod in a Regenerative circuit.

Figure 1 expresses the forces and speeds that results when using a cylinder with a 10 sq. Inch piston area and a 2sq.Inch rod area. This cylinder has a rod differential of nearly 1.25:1. Applying 45.46 LPM flow on both ports of cylinder allows it to extend at a rate of 29.33 meters per min. The same cylinder, with 45.46 LPM kinked into the piston end while the single acting rod end is associated with the tank, would extend at 5.867 meters per min.

In Figure 2, when the cylinder is retracting the force as well as the speed are similar. The force is around 35585N and the speed is around 7.3152 meters per min

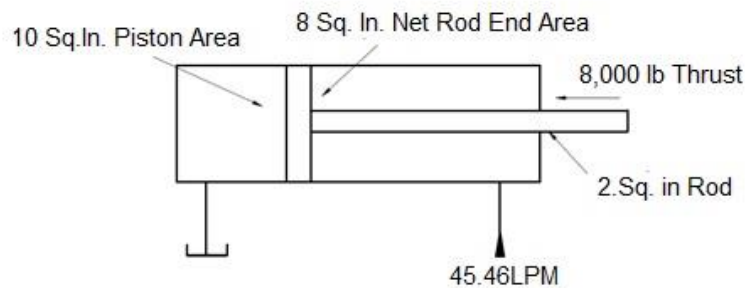

Figure.2 Small diameter rod in a Retracting cylinder

Frequently when the cylinder has a smaller rod diameter for regeneration, it will not be able to work on a set pressure. As forces are very less it makes impractical if it does extend. The speed of the extension stroke of the cylinder is greater than retraction stroke. Most regeneration circuits are in practice with cylinders with a 2:1 rod ratio. In 2:1 Rod ratio, the area of the piston side is twice the areas of its side rod. In general, extension and retraction speed and power is identical with an area difference of exactly 2:1.

1.1 Regenerative circuit with a 2:1 ratio:

The flow and forces are indicated for a cylinder in regeneration circuit with 2:1 area ratio. Observing variation in the behavior of forces and speed using set pressure and flow of oil. Cylinders which have an exact 2:1 area ratio. In actual practice only specially made cylinders have an exact 2:1 ratio of piston and rod end area [1, 2].

Having a 2:1 area ratio, the forces and speeds on extension and retraction are indistinguishable. As per Figure 3 it shows that regenerating cylinder acts like a ram-type cylinder [3]. Since both ports attached to the same power source, the effect of the piston area outside the rod diameter is negligible. Pressure on both sides of the area around the rod makes the piston area at this stage unserviceable. As the cylinder extends during regenerative, the force is halved while speed is doubled.

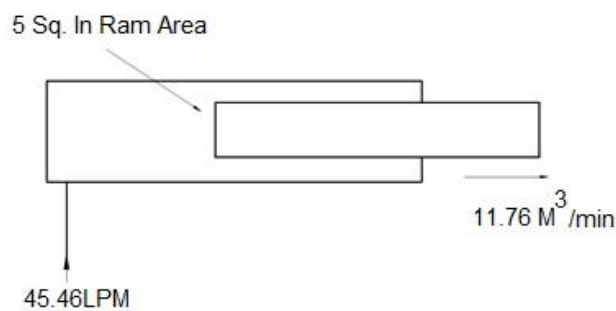

Figure.3 Ram-type cylinder extending. (same force and speed as regeneration.)

During regeneration, there is no flow of oil towards the tank. All oil from the pump goes allowed to the cylinder. Fluids from the rod end of the cylinder gets mixed with flow of pump and goes to the piston end. The fluid from the rod end, added to pump oil going to the cap end, doubles the cylinder's speed.

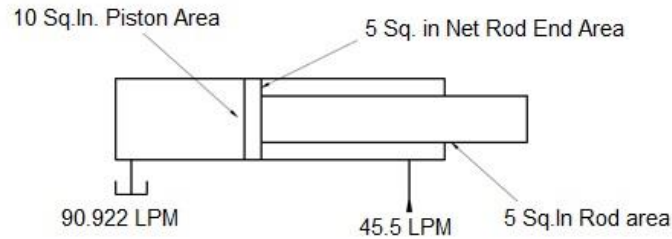

Figure.4 2:1 Rod Retracting in a cylinder

Figure 4 shows force and speed when a 2:1 oversize rod cylinder retracts. Pump flow of 10 GPM enters the rod port and the cylinder retracts using the 5in² area. Speed during retraction is the same as when the cylinder regenerates forward. Flow from the cylinder cap end port is twice pump flow as it retracts because cap end area is twice rod end area. A conventional regenerative circuit has double flow through the valving while the cylinder extends and retracts [4].

The main objective of the present work is to design and analyze a regenerative type hydraulic circuit and design a basic hydraulic circuit and the velocities of the piston is obtained in basic hydraulic circuit and Regenerative hydraulic circuit, Their cycle time and efficiency of the regenerative type hydraulic circuit is to be obtained during the research[5].

2. Comparison of regenerative circuit with basic hydraulic circuit

The objective and scope of Regenerative hydraulic circuits were compared with the basic hydraulic circuit was designed using a software automation Studio. The electrical circuit for both the hydraulic circuits is designed using relay connection which was developed using the same software. The designed hydraulic circuits were compared and the circuits are actuated with different flow rate and analyzed.

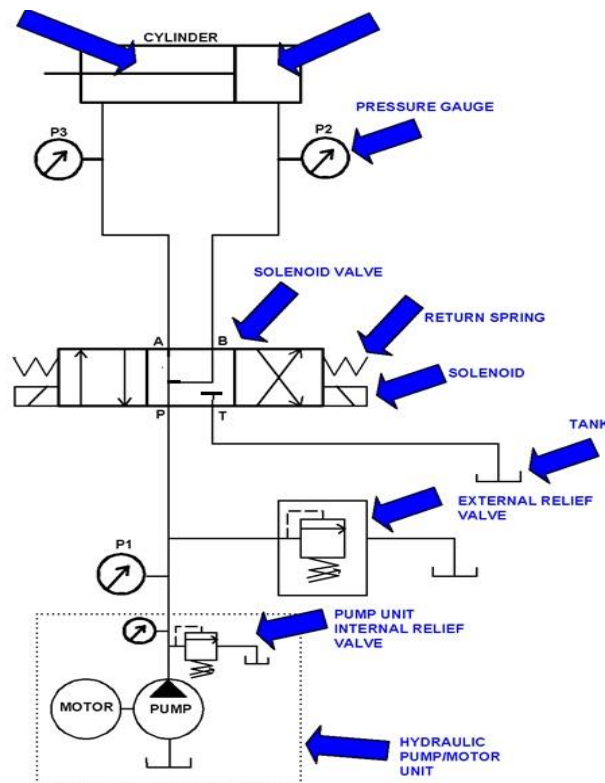

Figure 5. Design of Regenerative hydraulic circuit

Hydraulic Regenerative circuit is clearly shown in figure 5. Connect the hydraulic control system by means of hoses according to the hydraulic circuit diagram and the electric control according to the electrical circuits.

Switch on the pump on and inspect for some leakage in the system. Set the pressure relief valve to 15 bar so that manometer reading reads 15 bar respectively.

Adjust the throttle value check to scale position 1 so that piston of the single-rod cylinder extends towards rod meanwhile, oil gushes from pump to direct control valve port P to cylinder in through port A on process of push-button due to actuation of solenoid and initiating the spring to compress. Enter the pressure values (during extending) on piston side and note down the time taken for full extension.

Leaving the throttle check valve to scale position 1 so that the piston of the single-rod cylinder retracts to cap end since, oil rushes from pump to directional control valve port P to cylinder in through port B and oil from cap end goes back to reservoir from port A to directional control valve then to reservoir from it. on operation of push-button due Breaking of circuit and causing the compressed spring to release. Enter the pressure values (during retraction) on piston side and note down the time taken for full extension [6].

Procedures were repeated for scale positions of 1.5, 2.0, 2.5, and 3.0 and tabulate the same to obtain a characteristic curve of piston velocity and position of flow control valve.



Figure 6 Experimentation Setup

Table 1. Working Unit Specifications

Voltage Rating	230/400 Volts
Power Rating	2.2 KW
Frequency	50Hz
Power Factor	Cos 0.73
Flow Rate	1400l/min

3. Numerical techniques

3.1 Details of single rod double acting cylinder

Piston diameter $D = 2.5 \text{ cm} = 0.025\text{m}$ Piston rod diameter $d = 1.6 \text{ cm} = 0.016\text{m}$

Rod differential is the ratio of area of piston to the area of piston excluding rod area

Area of the piston (blank end): $A_1 = \pi D^2 / 4 = (\pi \times 2.5^2) / 4 = 4.9 \text{ cm}^2 = 4.90 \times 10^{-4} \text{ m}^2$

Area of piston excluding the rod area (rod end): $A_2 = \pi(D^2 - d^2) / 4 = 2.9 \text{ cm}^2 = 2.9 \times 10^{-4} \text{ m}^2$

The ratio of A_1 to A_2 is the rod differential = $A_1:A_2 = 1.69:1$

3.2 Piston Velocity:

$$Velocity = \frac{Distance\ Travelled\ by\ the\ piston}{Time\ taken\ for\ travel}$$

Table 2. Tabular column for basic hydraulic circuit

SCALE POSITION (TURNS)	CYLINDER POSITION (mm)	M1 (bar)	M2 (bar)	M3 (bar)	TRAVEL TIME (s)		VELOCITY (m/s) V=d/t	
					EXTENSION	RETRACTION	EXTENSION	RETRACTION
0	0	15	0	0	0	0	0	0
1	200	15	4	10	1.85	2.47	0.108	0.081
1.5	200	15	4	10	1.59	2.25	0.126	0.089
2	200	15	4	10	1.43	2.05	0.140	0.098
2.5	200	15	4	10	1.38	1.98	0.145	0.101
3	200	15	4	10	1.31	1.90	0.153	0.105

Calculations for Basic hydraulic circuit based on Equation 1

Trial 1) Velocity during extension:

$$Velocity = 200 / 1.31 = 153.3 \text{ m} = 0.153 \text{ m/s}$$

Velocity during retraction:

$$Velocity = 200 / 1.90 = 105.2\text{mm} = 0.1052\text{m/s}$$

Trial 1) Velocity during extension:

$$Velocity = 200 / 1.19 = 168.067\text{mm} = 0.168067\text{m/s}$$

Velocity during retraction:

$$Velocity = 200 / 1.92 = 104.166\text{mm/s} = 0.104166\text{m/s}$$

Table 3: Tabular column for Regenerative hydraulic circuit

SCALE POSITION (TURNS)	CYLINDER POSITION (mm)	M1 (bar)	M2 (bar)	M3 (bar)	TRAVEL TIME (s)		VELOCITY (m/s)	
					EXTENSION	RETRACTION	EXTENSION	RETRACTION
0	0	15	0	0	0	0	0	0
1	200	15	5	11	1.56	2.57	0.128	0.077
1.5	200	15	5	11	1.45	2.27	0.137	0.088
2	200	15	5	11	1.36	2.08	0.147	0.096
2.5	200	15	5	11	1.28	2.00	0.156	0.1
3	200	15	5	11	1.19	1.92	0.168	0.104

4. Observation

From the available data, the velocity of the extension stroke has been increased in a Regenerative circuit by = 0.168057-0.153 =0.015067 m/s

The increase is = (0.168057) / (0.153) -1 = 0.098 =9.8%

During Retention stroke, the velocity in Regenerative circuit is decreased by = 0.001034 m/s

There is a reduction in speed by 0.001034m/s and the decrease are around (0.1052)/ (0.10466) -1 = 0.009838 = 0.9828%

4.1 Cycle Efficiency Calculation of Regenerative Hydraulic Circuit:

Basic hydraulic circuit,

To complete one cycle = T1 +T2 =1.31 +1.90 = 3.2s

No of Cycles in one minute = 60 /3.2 =18.75cycles/min

Regenerative Hydraulic circuit,

To complete one cycle =T1+T2= 1.19+1.92 = 3.11s

No of cycles in one minute = 60/3.11 = 19.29cycles/min

From an observation, associating the given regenerative hydraulic circuit cycles to that of a basic hydraulic circuit cycles, we can make a binding point that the piston in regenerative type completes more number of cycles than that of the piston in a basic type. Here in regenerative type the piston in cylinder completes almost 19.29 cycles in a minute but in basic type the piston can make it to 18.75 cycles in same time, hence a regenerative circuit can provide up to 1 cycle more than the basic hydraulic circuit under same working unit and conditions [6].

4.2. Cycle efficiency

$$\eta = 1 - \frac{\text{(number of cycles of basic hydraulic circuit per minute)}}{\text{(Number of cycles of regenerative hydraulic circuit per minute)}}$$

$$= 1 - (18.75 / 19.29) = 0.04 = 4\%$$

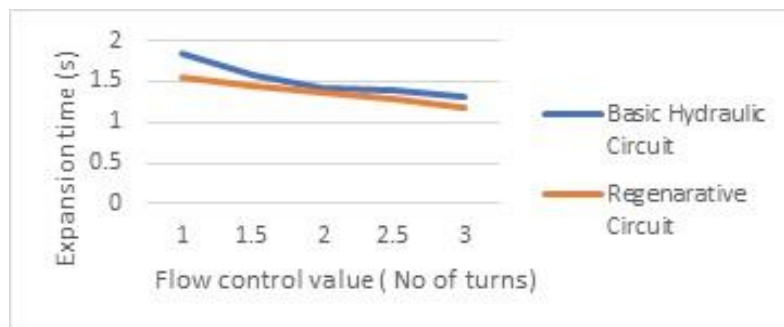

Figure 7. Comparison of Expansion time and Flow control valve

In Figure 7, the expansion time of Hydraulic regenerative circuit is consistently lower when compared with basic hydraulic circuit. By the help of the graph it can be said that the cycle time and the productivity can be reduced by Regenerative circuit.

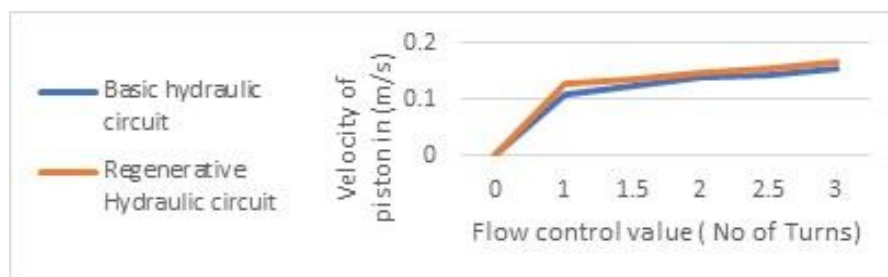

Figure 8. Comparison of velocity and Flow control valve

From Figure 8 clearly explains that the expansion time is consistently lower in a regenerative circuit, when compared with a basic hydraulic circuit. In the 2nd graph, the velocity of the piston in Regenerative hydraulic circuit is higher than that of a basic hydraulic circuit [7].

5. Future scope in the field of energy efficient regenerative circuit

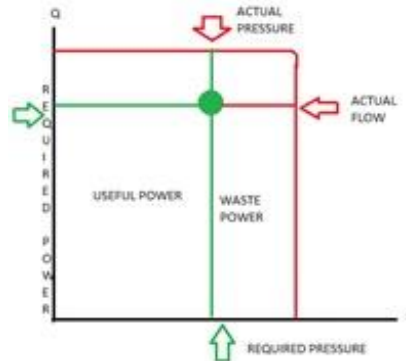

Figure 9. Existing regenerative circuit Power v/s Pressure graph

In existing regenerative hydraulic circuit as shown in the figure 9, an excess pressure or force is created inside the cylinder. This force is used for increasing the velocity of the cylinder and reducing the cycle time. There are various other options that can be implemented to conserve or reduce the power consumption. These can help in increasing the efficiency of the Regenerative hydraulic circuit.

6. Incorporation of accumulator to the conducted regenerative circuit

This concept of Hydraulic regenerative circuit can also be used with incorporation of accumulator into the circuit. Once an accumulator is in the circuit, the excess pressure can be stored in the accumulator. The excess pressure stored in the accumulator can be used after a certain dwell time. During the dwell time the hydraulic motor can be switched off for the particular dwell time although the double acting cylinder will be working. By this concept, a small amount of energy can be conserved. The power consumed by the hydraulic pump can be reduced by incorporation of accumulator into a regenerative circuit. In long run a large amount of power can be saved [8].

7. Variable speed drive in regenerative circuit

Energy cost is a substantial factor in economic activity. The necessities of energy shortage call for energy conservation actions, which essentially mean using a reduced amount of energy for the same level of activity [9]. Due in to use of oversized motors and high use of energy to run than the pump hardly requires. The problem of energy wastage is increasing and made worse. This is because motors are only obtainable with a definite quantity of speed. They are tending to fit the next superior size comparative to the requirement and then throttle the output. Normally, electric motors only have solitary speed; if you have to change the speed of the motor you must purchase a different motor with varying capacity. What if there is selection to control the speed with respect to time [10].

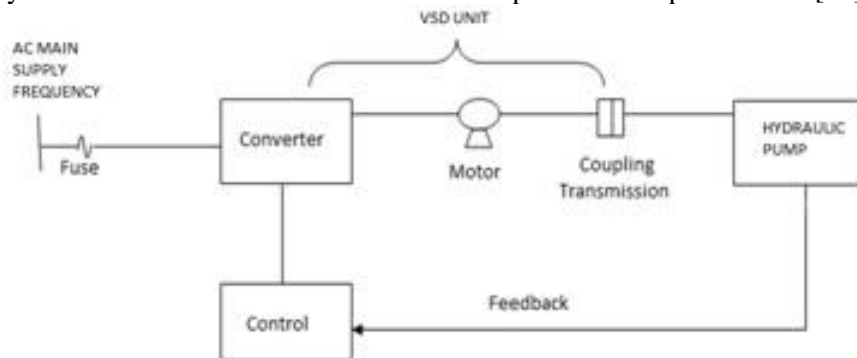

Figure 10. Incorporation of VSD in Hydraulic pump circuit

Variable speed drives (VSD), frequency inverter or AC drive etc. It is an electric device to change utility power source to adjustable frequency to control AC motor in variable speed operation. The variable speed drive (VSD) converts the supply frequency and voltage to the required frequency and voltage to drive a motor. Hence, VSD converts the supply frequency and voltage to the frequency and voltage required to drive a motor at a desired speed other than its rated speed.

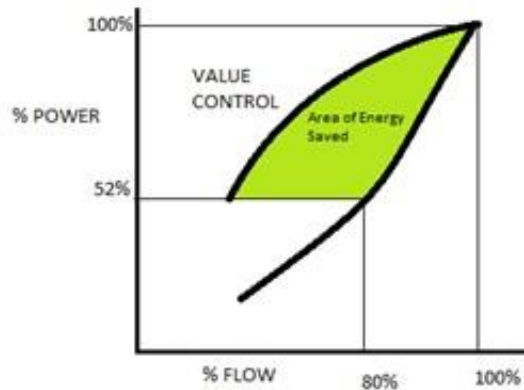

Figure 11: Power v/s Flow graph when VSD is implemented in the circuit

8. Energy saving with variable speed drive in a regenerative hydraulic circuit

The fixed speed motor load application such as the hydraulic pump supplies direct AC power. The energy saving is obtained by variable speed drive by using pump affinity laws. By using a Variable speed drive to reduce the speed of the pump motor speed from 100% to 80% and could save 50% of energy. Reducing pump speed not only reduces energy consumption but also reduces noise and vibration [11].

9. Regenerative hydraulic circuit always has its benefits over a basic hydraulic circuit.

Various hydraulic components like 4/2 and 3/2 DCV, 2way FCV, PRV, pressure gauges, double acting cylinder, hose pipes were used to successfully build a hydraulic circuit with an integrated electric circuit for working of the system and based on the above analysis we have the following comparison under fully open flow conditions of FCV.

Basic Hydraulic Circuit		Regenerative Hydraulic Circuit	
Piston Extension Velocity	0.153 m/s	Piston extension Velocity	0.168 m/s
Piston Extension time	1.31 sec	Piston extension time	1.19 sec

By this research work we can conclude that for any power unit for a hydraulic circuit, the speed of extension stroke in a regenerative hydraulic circuit is faster than that of basic circuit. The cycle time of a regenerative hydraulic circuit declines considerably. Also, the cycle efficiency of regenerative hydraulic circuit can be increased by 5.3% when associated to a basic hydraulic circuit by implementing the method as stated in our project.

This means that regeneration circuit is more economical compared to a regular motor, tank and pump that can produce the required cycle time. It also observed that the circuit cost less to operate and increases the machine age [12].

Acknowledgements

Authors thank Bosch-Rexroth India Ltd., Bengaluru, The drive and Control Company for providing facilities to conduct experimentation for energy conservation study using Variable frequency drives in CNC machines. Also, ACE Manufacturing Systems Ltd, Bengaluru, for providing necessary facilities for conducting energy conservation study on CNC machine.

10. References

- [1] Dr. S. J. Clegg. April 1996, A Review of Regenerative Braking Systems, University of Leeds, Institute for Transport Studies Working Paper 471
- [2] Ramesh S, et.al. "A review paper on optimization of energy efficient systems in machine tool technology", STM Journal, trends in machine design Volume-2, Issue-2 pp 1-8
- [3] Amitesh Kumar, 2011, '*Hydraulic Regenerative Braking System*', International Journal of Scientific & Engineering Research Volume 3, Issue 4, April-2012 ISSN 2229-5518.
- [4] Tri-Vien Vu, Chih-Keng Chen and Chi-Wei Hung "*Study of Hydraulic regenerative braking systems in Hydraulic Hybrid vehicles*", Journal of Science and Engineering Technology, Vol. 7, No.4, pp. 9-18.
- [5] Andrew Brown, et. al., April 26, 2016, "Hydraulic Drivetrain with Regenerative Braking, The University of Pennsylvania", USA, MEAM-446-2012-13.
- [6] Bryan D'Souza, Andrew Kneifel, Victor Singh, Matthew Williams. April 21, 2009. "Optimizing a Hydraulic Regenerative Braking System for a 20" Bicycle Wheel" University of Michigan Project 24 of ME450.
- [7] Dewey, C., F. T. Elder and D. R. Otis 1974 "Accumulator-charged hydrostatic drive for cars saves energy. *Hydraulics and Pneumatics*" Vol 10, 180-183.
- [8] Wojciechowski, P. H. and H. Searl Dunn 1975 "Energy regeneration and conversion efficiency in a hydraulic hybrid propulsion system" High Speed Ground Transportation Journal, 9(1), 383-392.'
- [9] Ramesh S, et.al 2017, "*An Energy Conservation Strategy using variable frequency drive for a Hydraulic clamping system in a CNC Machine*", Elsevier Materials Today: Proceedings ICMMM-2017
- [10] Mr. Rajendrakumar Patel Et.al February 2015 "Energy Conservation Opportunity with a Variable Frequency Drive in Boiler Feed Pump" IJAIEM Volume 4, Issue 2,
- [11] Zin Win, Than Naing Win Jr et.al. 2008 "Design of Hydraulics circuits for CNC Lathe Machine Converted from Convectional Lathe Machine World Academy of Science, Engineering and Technology" pp42
- [12] Tonglin Shang April 2004 "Improving Performance of an Energy Efficient Hydraulic circuit" University of Saskatchewan, Saskatoon
- [13] Sergio Valente, Helder Ferreira. "Braking Energy Regeneration using hydraulic systems" Mestrado em Electrónica e Computadores
- [14] Koustubh Dinesh Lagwankar January-February 2013 "Hydraulic Regenerative system for bicycle" IJERA, Vol. 3, Issue 1, pp 869-875 ISSN: 2248-9622
- [15] Kerem Bayar et.al 2012 "Modeling and control of a brake system for an extended range vehicle equipped with axle motors" International Journal Vehicle Design Vol. 58 Nos. 2/3/4.