

Direct Torque Control Strategy for Doubly Fed Induction Machine under Low Voltage Dips

G. Venu Madhav*, Y. P. Obulesu**

* Department of Electrical and Electronics Engineering, Padmasri Dr. B. V. Raju Institute of Technology

** Department of Electrical and Electronics Engineering, LakiReddy BaliReddy College of Engineering

Article Info	ABSTRACT
<p>Article history:</p> <p>Received Jun 28, 2012 Revised Oct 15, 2012 Accepted Oct 25, 2012</p> <hr/> <p>Keyword:</p> <p>Crowbar protection Direct torque control Doubly fed induction machine Reference generation strategy Voltage dips</p>	<p>This paper proposes a control strategy of generating a rotor flux amplitude reference for Doubly Fed Induction Machine (DFIM) based wind turbines. In addition to that a Direct Torque Control (DTC) strategy that provides fast dynamic response accompanies the overall control of the wind turbine. It is specially designed to address perturbations, such as voltage dips, keeping controlled the torque of the wind turbine, considerably reducing the stator and rotor over currents during faults. Despite the fact that the proposed control does not totally eliminate the necessity of the typical crowbar protection for this kind of turbines, it eliminates the activation of this protection during low depth voltage dips.</p> <p style="text-align: right;"><i>Copyright © 2012 Institute of Advanced Engineering and Science. All rights reserved.</i></p>

Corresponding Author:

G. Venu Madhav

Department of Electrical and Electronics Engineering,
Padmasri Dr. B. V. Raju Institute of Technology, Vishnupur, Narsapur, Medak Dist., 502313, AP, India.
Email: venumadhav.gopala@gmail.com

1. INTRODUCTION

The worldwide concern about the environment has led to increasing interest in technologies for generation of renewable electrical energy. One way of generating electricity from renewable sources is to use wind turbines. The most common type of wind turbine is the fixed-speed wind turbine with the doubly fed induction generator directly connected to the grid.

This paper focuses the analysis on the control of Doubly Fed Induction Machine (DFIM) based high-power wind turbines when they operate under presence of voltage dips. Most of the wind turbine manufacturers build this kind of wind turbines with a back-to-back converter sized to approximately 30% of the nominal power [1]. This reduced converter design provokes that when the machine is affected by voltage dips, it needs a special crowbar protection. [2] describes a solution that makes it possible for wind turbines using doubly-fed induction generators to stay connected to the grid during grid faults. The key of the solution is to limit the high current in the rotor in order to protect the converter and to provide a bypass for this current via a set of resistors that are connected to the rotor windings, in order to avoid damages in the wind turbine and meet the grid-code requirements; it is also described in [3].

Worldwide, there is an ambition to install a large amount of wind power and to increase the share of energy consumption that is produced by wind turbines. The interaction with the grid becomes increasingly important then [4]. This can be understood as follows. When all wind turbines would be disconnected in case of a grid failure, these renewable generators will—unlike conventional power plants—not be able to support the voltage and the frequency of the grid during and immediately following the grid failure. This would cause major problems for the systems stability [5]. It is therefore worldwide recognized that to enable large-scale application of wind energy without compromising system stability, the turbines should stay connected to the grid in case of a failure. They should—similar to conventional power plants—supply active and reactive

power for frequency and voltage support immediately after the fault has been cleared, which is normally within a fraction of a second.

Recently, some papers have been published that discuss the protection of DFIGs during grid disturbances [6]–[9]. However, most papers give little information on the way the protection scheme is implemented. Further, they give only limited information on the behavior of the rotor voltage and current during disturbances, while these signals are important during disturbances. Rotor currents or voltages that are too high might destruct the converter in the rotor circuit. The main objective of the control strategy proposed in this paper is to eliminate the necessity of the crowbar protection when low-depth voltage dips occur. Hence, by using Direct Torque Control (DTC), with a proper rotor flux generation strategy, during the fault it will be possible to maintain the machine connected to the grid, generating power from the wind, reducing over currents, and eliminating the torque oscillations that normally produce such voltage dips.

In Figure 1, the wind turbine generation system together with the proposed control block diagram is illustrated.

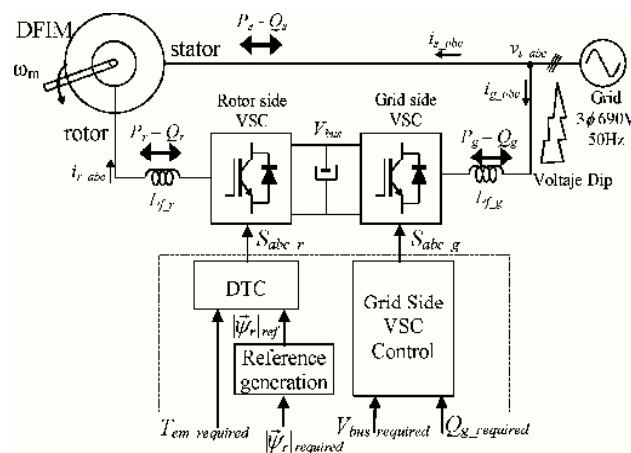

Figure 1. Wind energy generation system based on the DFIM

The DFIM is supplied by a back-to-back converter through the rotor, while the stator is directly connected to the grid. This paper only considers the control strategy corresponding to the rotor side converter. The grid-side converter is in charge to keep controlled the dc bus voltage of the back-to-back converter and the reactive power is exchanged through the grid by this. As can be noticed from Figure 1, the DFIM control is divided into two different control blocks. A DTC that controls the machine's torque (T_{em}) and the rotor flux amplitude ($|\psi_r|$) with high dynamic capacity, and a second block that generates the rotor flux amplitude reference, in order to handle with the voltage dips. The simlink model of the wind energy generation system based on DFIM is shown in Figure 3. The Figure 3 will be same for both without reference and with reference generation. The rotor flux reference generation strategy is shown in Figure 4, which is the only addition to the with reference generation.

When the wind turbine is affected by a voltage dip, it will need to address three main problems: from the control strategy point of view, the dip produces control difficulties, since it is a perturbation in the winding of the machine that is not being directly controlled (the stator); the dip generates a disturbance in the stator flux, making necessary higher rotor voltage to maintain control on the machine currents; and if not special improvements are adopted, the power delivered through the rotor by the back-to-back converter, will be increased due to the increase of voltage and currents [3] in the rotor of the machine, provoking finally, an increase of the dc bus voltage [10].

Taking into account this, depending on the dip depth and asymmetry, together with the machine operation conditions at the moment of the dip (speed, torque, mechanical power, etc.), implies that the necessity of the crowbar protection is inevitable in many faulty situations. However, in this paper, a control strategy that eliminates the necessity of the crowbar activation in some low depth voltage dips is proposed.

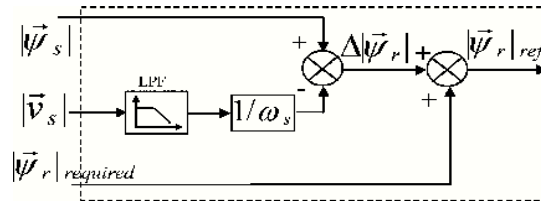

Figure 2. Rotor flux reference generation strategy

2. PROPOSED METHOD

2.1. Mathematical Analysis

When a voltage dip occurs, the stator flux evolution of the machine is imposed by the stator voltage equation

$$\mathbf{v}_s^s = R_s \mathbf{i}_s^s + (d\Psi_s^s/dt) \quad (1)$$

In general, since very high stator currents are not allowed, the stator flux evolution can be approximated by the addition of a sinusoidal and an exponential term [1] (neglecting R_s)

$$\begin{aligned} \Psi_{\alpha s} &= K_1 e^{-K_2 t} + K_3 \cos(\omega_s t + K_4) \\ \Psi_{\beta s} &= K_5 e^{-K_2 t} + K_3 \sin(\omega_s t + K_4) \end{aligned} \quad (2)$$

Sinusoidal currents exchange with the grid will be always preferred by the application during the fault. It means that the stator and rotor currents should be sinusoidal.

However, by checking the expressions that relate the stator and rotor currents as a function of the fluxes

$$\begin{aligned} \mathbf{i}_s^s &= (L_h / \sigma L_r L_s) ((L_r / L_h) \Psi_s^s - \Psi_r^s) \\ \mathbf{i}_r^s &= (L_h / \sigma L_r L_s) ((L_s / L_h) \Psi_r^s - \Psi_s^s) \end{aligned} \quad (3)$$

It is appreciated that it is very hard to achieve sinusoidal currents exchange, since only the rotor flux amplitude is controlled by a DTC technique.

Consequently, as proposed in next section, a solution that reasonably cancels the exponential terms from (3) is to generate equal oscillation in the rotor flux amplitude and in the stator flux amplitude. Finally, as it will be later shown that the quality of the currents is substantially improved with this oscillatory rotor flux, rather than with constant flux.

2.1 Rotor Flux Reference Generation Strategy

As depicted in Figure 2, the proposed rotor flux amplitude reference generation strategy, adds a term ($\Delta|\Psi_r|$) to the required reference rotor flux amplitude according to the following expression:

$$\Delta|\Psi_r| = |\Psi_s| - (|\mathbf{v}_s| / \omega_s) \quad (4)$$

$$\begin{aligned} \Psi_s &= L_s \mathbf{i}_s + L_h \mathbf{i}_r \\ \Psi_r &= L_r \mathbf{i}_r + L_h \mathbf{i}_s \end{aligned}$$

or

$$\begin{aligned} \Psi_s &= \sqrt{\Psi_{ds}^2 + \Psi_{qs}^2} \\ \Psi_r &= \sqrt{\Psi_{dr}^2 + \Psi_{qr}^2} \end{aligned} \quad (5)$$

With $|\Psi_s|$, the estimated stator flux amplitude and $|\mathbf{v}_s|$ voltage of the grid (not affected by the dip). This voltage can be calculated by several methods, for instance, using a simple small bandwidth low-pass filter, as illustrated in Figure 3. It must be highlighted that constants $K_1 - K_5$ from (2) are not needed in the rotor flux reference generation reducing its complexity. Figure 4 shows the simulink model of rotor flux generation strategy which depicts the actual model of proposed rotor flux amplitude reference generation strategy.

Note that at steady state without dips presence, $\Delta|\psi_r|$ the term will be zero. However, when a dip occurs, the added term to the rotor flux reference will be approximately equal to the oscillations provoked by the dip in the stator flux amplitude. For simpler understanding, the voltage drop in the stator resistance has been neglected. The magnitude of stator flux and rotor flux can be calculated by (5) by knowing the values of stator, rotor self inductance, mutual inductance and stator, rotor currents at that instance or the values of stator and rotor flux can be calculated by taking the square root of summation of squares of direct and quadrature axis fluxes of stator and rotor respectively as mentioned in (5).

3. RESULTS AND DISCUSSIONS

The simulated wind turbine is a 2 MW, 690 V, = 1/3 and two pair of poles DFIM. The main objective of this simulation validation is to show the DFIM behavior when a low depth [in this case 30%, as illustrated in Figure 5(a)] symmetric voltage dip occurs with and without the proposed flux reference generation strategy and at nearly constant speed. The simulations are performed in MATLAB/Simulink.

During the dip, it is desired to maintain the torque controlled to the required value (20%), allowing to eliminate mechanical stresses to the wind turbine. This issue is achieved, as shown in Figure 5(b) and 6(b), only if the oscillatory rotor flux is generated. For this purpose, the rotor flux is generated according to the block diagram of Figure 2, generating an equivalent oscillation to the stator flux amplitude [see Figure 6(c)]. It must be pointed out that DTC during faults is a well-suited control strategy to reach quick flux control dynamics, as well as to dominate the situation, eliminating torque perturbations and avoiding mechanical stresses. Consequently, the proposed control schema maintains the stator and rotor currents under their safety limits, avoiding high over currents, as shown in Figure 6(d) and (e), either in the voltage fall or rise. The proposed strategy is analyzed for voltage fall which is created by using three phase fault block. However, as predicted in theory, it is hard to avoid a deterioration of the quality of these currents. Nevertheless, if the rotor flux is maintained constant, the currents will go further till their limit values, as shown in Figure 5(d) and (e), provoking in a real case, a disconnection of the wind turbine or an activation of the crowbar protection. Moreover, by mitigating the over currents of the rotor, the back-to-back converter is less affected by this perturbation, producing short dc bus voltage oscillations, as illustrated in Figure 6(a).

Finally, it can be said that the proposed control is useful at any operating point of the wind turbine, as well as at any type of faults (one phase, two phases, etc.). As shown in the Figure 3, the proposed strategy is analyzed for three phases ground fault. The performance will be limited only, when the rotor voltage required is higher than the available at a given dc bus voltage.

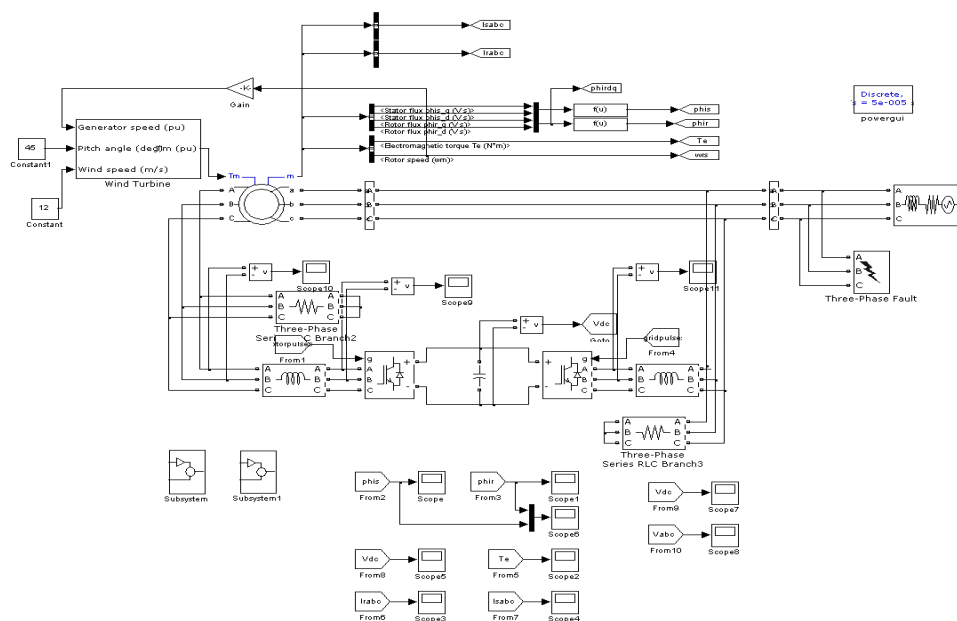

Figure 3. MATLAB/Simulink model of proposed control strategy

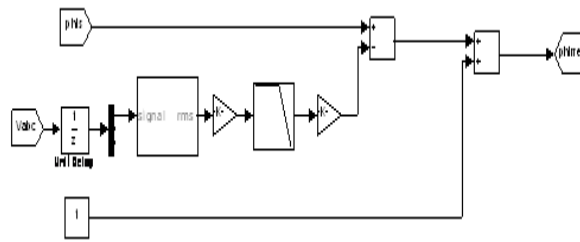
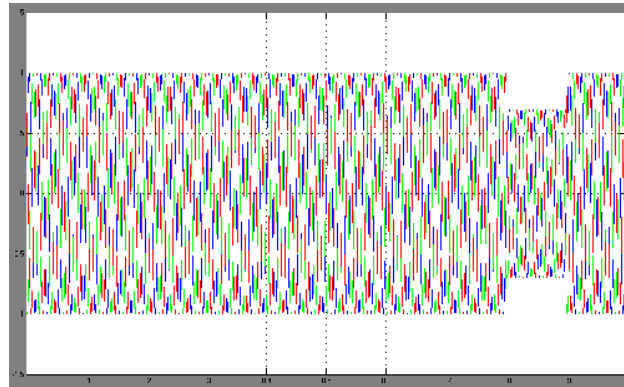
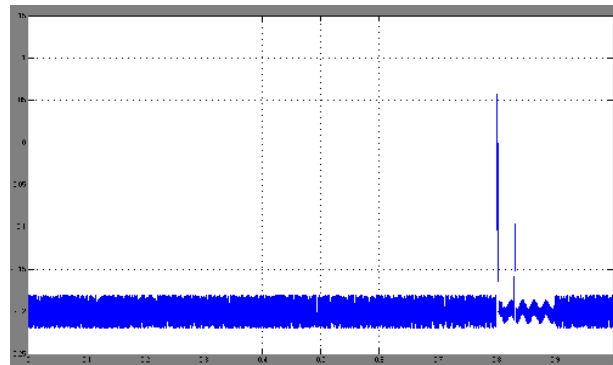

Figure 4. MATLAB/Simulink model of reference flux generation strategy



(a)



(b)



(c)

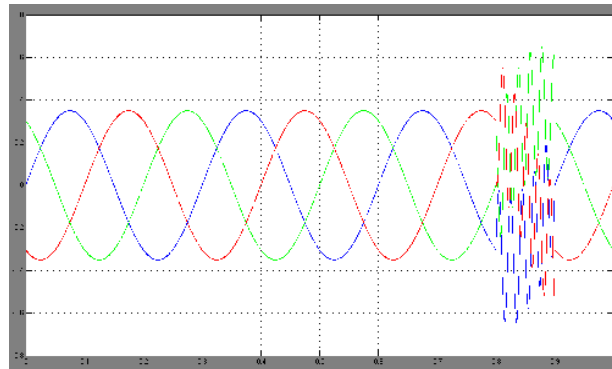

(d)

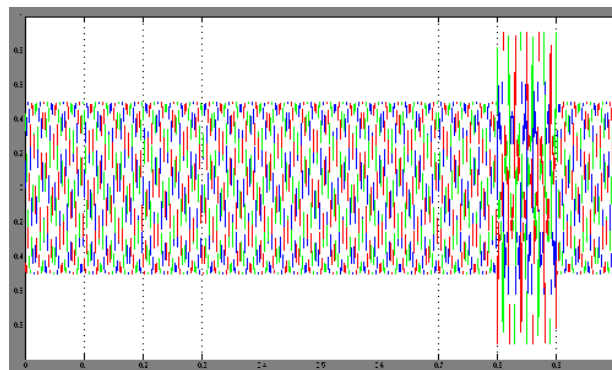

(e)

Figure 5. Simulation results of DFIM without proposed reference generation. (a) Stator voltage. (b) Torque (c) Stator and rotor fluxes (d) Rotor currents. (e) Stator currents w.r.t. time t in secs

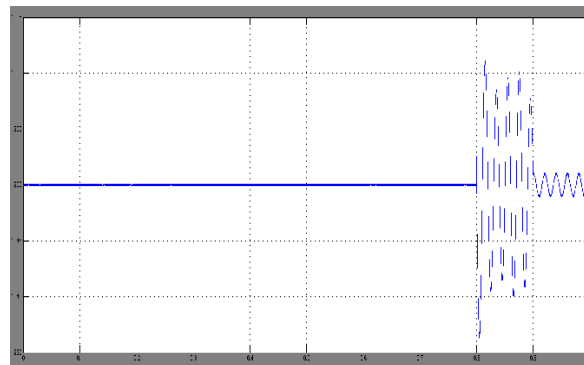

(a)

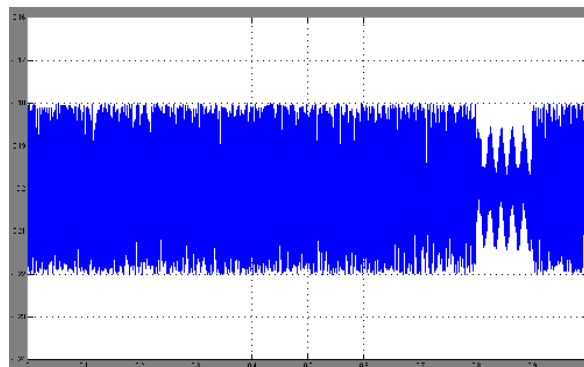

(b)

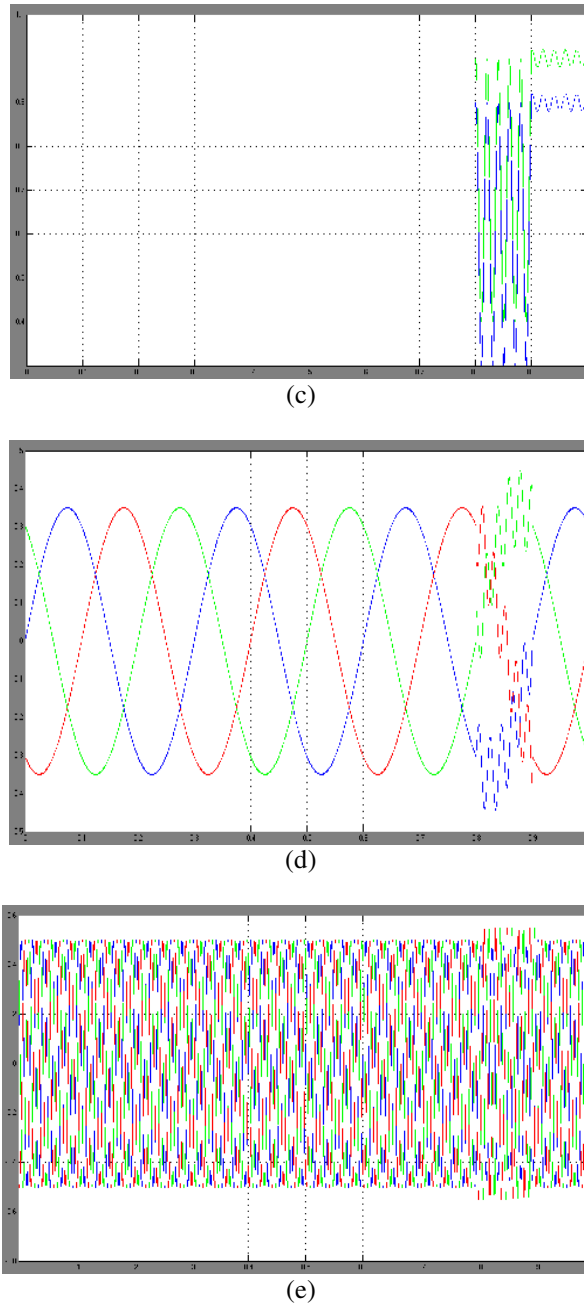

Figure 6. Simulation results of DFIM with proposed reference generation. (a) DC bus voltage. (b) Torque. (c) Stator and rotor fluxes. (d) Rotor currents (e) Stator currents w.r.t. time t in secs

4. CONCLUSION

The proposed control strategy of DTC for DFIM mitigates the necessity of the crowbar protection during low depth voltage dips. In fact, the dc bus voltage available in the back-to-back converter, determines the voltage dips depth that can be kept under control. Simulation results for without and with reference rotor flux generation is shown. DTC controls the machine torque and the rotor flux amplitude and the voltage dip is handled by the rotor flux reference generation.

It would be interesting to explore the possibility to generate a modified reference of rotor flux and torque, in order to be able to address deeper voltage dips without crowbar protection, which can be the future scope of the proposed control strategy.

REFERENCES

- [1] J. Lopez, E. Gubia, P. Sanchis, X. Roboam, and L. Marroyo, "Wind turbines based on doubly fed induction generator under asymmetrical voltage dips," *IEEE Trans. Energy Convers.*, vol. 23, no. 1, pp. 321–330, Mar. 2008.
- [2] Johan Morren, and Sjoerd W.H.de Haan., "Ride through of wind turbines with doubly-fed induction generator during a voltage dip," *IEEE Trans. Energy Convers.*, vol. 20, no. 2, pp. 435–441, Jun. 2005.
- [3] S. Seman, J. Niiranen, and A. Arkkio, "Ride-through analysis of doubly fed induction wind-power generator under unsymmetrical network disturbance," *IEEE Trans. Power Syst.*, vol. 21, no. 4, pp. 1782–1789, Nov. 2006.
- [4] J. G. Slootweg and W. L. Kling, "Modeling of large wind farms in power system simulations," in *Proc. IEEE Power Engineering Soc. Summer Meeting*, vol. 1, 2002, pp. 503–508.
- [5] "Modeling and analysing impacts of wind power on transient stability of power systems," *Wind Eng.*, vol. 26, no. 1, pp. 3–20, 2002.
- [6] J. B. Ekanayake, L. Holdsworth, X. G. Wu, and N. Jenkins, "Dynamic modeling of doubly-fed induction generator wind turbines," *IEEE Trans. Power Syst.*, vol. 18, no. 2, pp. 803–809, May 2003.
- [7] L. Holdsworth, X. G. Wu, J. B. Ekanayake, and N. Jenkins, "Comparison of fixed speed and doubly-fed induction wind turbines during power system disturbances," *Proc. Inst. Elect. Eng., Commun.*, vol. 150, no. 3, pp. 343–352, May 2003.
- [8] S. Seman, J. Niiranen, S. Kanerva, and A. Arkkio., "Analysis of a 1.7 MVA doubly fed wind-power induction generator during power systems disturbances," *Proceedings of NORPIE 2004*, Trondheim, Norway, Jun. 2004.
- [9] Johan Morren, and Sjoerd W.H.de Haan., "Short-circuit current of wind turbines with doubly fed induction generator," *IEEE Trans. Energy Convers.*, vol. 22, no. 1, pp. 174–180, Mar. 2007.
- [10] X. Dawei, R. Li, P. J. Tavner, and S. Yang, "Control of a doubly fed induction generator in a wind turbine during grid fault ride-through," *IEEE Trans. Energy Convers.*, vol. 21, no. 3, pp. 750–758, Sep. 2006.

BIOGRAPHIES OF AUTHORS



G. Venu Madhav received his B.Tech. degree in Electrical and Electronics Engineering from Jawaharlal Nehru Technological University, Hyderabad in 2002. M.Tech. degree in Power and Industrial Drives from Jawaharlal Nehru Technological University, Anantapur in 2005. He is pursuing Ph.D. from Jawaharlal Nehru Technological University, Hyderabad. Currently he is working as a Associate Professor, Dept. of EEE, BVRIT, Narsapur, Medak Dist. He has published several National and International Journals and Conferences. His area of interest is Advanced Control strategies of Electric Drives, Microprocessors and Microcontrollers, Fuzzy logic & ANN applications, and Network Analysis. Have professional society memberships in IETE (M), ISTE (LM), IE (AM), SESI (LM) and IAENG (M).



Y.P.Obulesu received his B.E. degree in Electrical and Electronics Engineering from Andhra University, Visakhapatnam in 1996. M.Tech. degree in Power Electronics and Drives from IIT, Kharagpur, in 1998. He received his Ph.D. degree from Jawaharlal Nehru Technological University, Hyderabad in 2006. Currently he is working as a Professor and Dean of R & D, Dept. of EEE, LBRCEC, Mylavaram, Krishna Dist. He has published several National and International Journals and Conferences. His area of interest is Advanced Control strategies of Electric Drives, SMPS, Multilevel inverters, Harmonic minimization, power quality, FACTS, Solar powered Electric Vehicles, DSP & FPGA control of power electronics and drives, Wavelets, Fuzzy logic & ANN applications to power electronics and drives. Have professional society memberships in IEEE, ISTE (LM) and SSI (LM).