

PAPER • OPEN ACCESS

## Garbage monitoring system using IoT

To cite this article: A Anitha 2017 *IOP Conf. Ser.: Mater. Sci. Eng.* **263** 042027

View the [article online](#) for updates and enhancements.

### Related content

- [Notification to the Readers](#)
- [Home security system using internet of things](#)  
A Anitha
- [Fabrication of Scalable Indoor Light Energy Harvester and Study for Agricultural IoT Applications](#)  
M Watanabe, A Nakamura, A Kunii et al.

# Garbage monitoring system using IoT

**Anitha A**

School of Information Technology and Engineering, VIT University, Vellore-632014, Tamil Nadu, India.

E-mail: aanitha@vit.ac.in

**Abstract** Nowadays certain actions are taken to improve the level of cleanliness in the country. People are getting more active in doing all the things possible to clean their surroundings. Various movements are also started by the government to increase cleanliness. We will try to build a system which will notify the corporations to empty the bin on time. In this system, we will put a sensor on top of the garbage bin which will detect the total level of garbage inside it according to the total size of the bin. When the garbage will reach the maximum level, a notification will be sent to the corporation's office, then the employees can take further actions to empty the bin. This system will help in cleaning the city in a better way. By using this system people do not have to check all the systems manually but they will get a notification when the bin will get filled.

## 1. Introduction

IoT or Internet Things refers to the network of connected physical objects that can communicate and exchange data among themselves without the desideratum of any human intervention. It has been formally defined as an “Infrastructure of Information Society” because IoT sanctions us to amass information from all kind of mediums such as humans, animals, conveyances, kitchen appliances. Thus, any object in the physical world which can be provided with an IP address to enable data transmission over a network can be made part of IoT system by embedding them with electronic hardware such as sensors, software and networking gear. IoT is different than Internet as in a way it transcends Internet connectivity by enabling everyday objects that utilizes embedded circuits to interact and communicate with each other utilizing the current Internet infrastructure

Since then the scope of IoT has grown tremendously as currently it consists of more than 12 billion connected devices and according to the experts it will increase to 50 billion by the end of 2020. With the advent of IoT both manufacturers and consumers have benefited. Manufacturers have gained insight into how their products are used and how they perform out in the real world and increase their revenues by providing value added services which enhances and elongates the lifecycle of their products or services. Consumers on the other hand have the ability to integrate and control more than one devices for a more customized and improved user experience.

In this paper, we are going to propose a system for the immediate cleaning of the dustbins. As dustbin is considered as a basic need to maintain the level of cleanliness in the city, so it is very important to clean all the dustbins as soon as they get filled. We will use ultrasonic sensors for this system. The sensor will be placed on top of bin which will help in sending the



information to the office that the level of garbage has reached its maximum level. After this the bin should be emptied as soon as possible. The concept of IoT when used in this field will result in a better environment for the people to live in. No more unsanitary conditions will be formed in the city. With the help of this system minimal number of smart bins can be used around the whole city and the city will still be much cleaner.

There has been an unprecedented growth in the number of devices being connected to the Internet since past few years. All these devices connected to the internet are part of the IoT infrastructure which can communicate with each other. The IoT network consists of embedded electronics, sensors and software that allows these devices to send and receive data among each other. This is why it is beneficial to use such an existing infrastructure for designing the proposed security system. The disadvantages of the existing system are that the employees have to go and check the bins daily whether they are filled or not, it results in high cost. If the bin doesn't get emptied on time then the environment becomes unhygienic and illness could be spread. The proposed system will help in removing all these disadvantages. The real-time information can be gained regarding the level of the dustbin filled on the system itself. It will also help in reducing the cost as the employees will have to go only at that time when the bin is full. This will also help in resource optimization and if the bins will be emptied at time then the environment will remain safe and free from all kinds of diseases. The cities will become more cleaner and the smells of the garbage will be much less.

The paper is organized as follows: Section 1 discuss about the introduction of IOT and its applications. Section 2, gives a details review of the focus of the paper. Section 3 talks about the materials and the methods to implement the proposed systems. Section 4 proposed the working model of the proposed system, whereas section 5 gives the configuration of the application. Section 6 explains the experimental results followed by conclusion and future enhancement as Section 7.

## **2. Literature review**

A Smart Dustbin proposed by [1], based on IoT in which the smart bin was built on a platform which was based on Aurdino Uno board which was interfaced with a GSM modem and an ultrasonic sensor. The sensor was placed on the top of the bin. A threshold level was set as 10cm. As the garbage reaches the level of threshold, the sensor triggers the GSM modem which alerts the associated authority till the garbage in the bin is emptied. At the end a conclusion was made that various issues like affordability, maintenance and durability were addressed when these smart bins were designed. It also contributed towards a hygienic and clean environment in the process of building a smart city.

The researchers [2] suggests the method for garbage management which is as follows. The bin was interfaced with a system based on microcontroller which had IR wireless systems with a central system that showed the current status of the garbage in the bin. The status was seen on a mobile based web browser with a html page by using Wi-Fi. To reduce the cost, they only used weight based sensors and on the sender's side they only used a Wi-Fi module to send and receive the data. In the end the sensor could only detect the weight of waste present in the bin but not the level of waste.

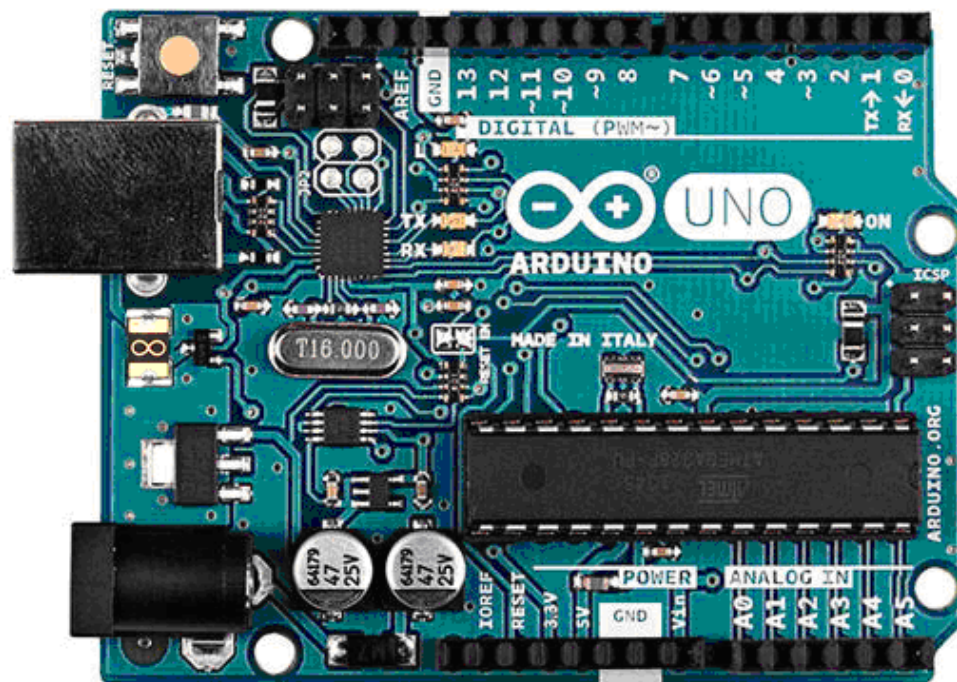
The author proposed a method for organizing the collection of the garbage in the commercial and residential areas of the cities [3]. In this system, the level of garbage in the bin was detected by the ultrasonic sensor which will send the data to the control room using the GSM module. A GUI was also developed to check the information that was related to the garbage for different locations, GUI was based on MATLAB so it was different. Two units were present in the system, slave unit was in the bin whereas the master unit was there in the control room. The sensor will check the level of garbage and send it to the slave unit which will further send the data to master unit which at last will inform the authorities to clean the bin.

This paper proposed Decision Support System which would be used for garbage collection in the cities[4]. This system handled the ineffective waste collection in the inaccessible areas of the city. The cameras were placed in those parts of the cities which were facing the most

problems. The system worked in two parts, the first part was to find the companies that were involved in collecting the waste and owned trucks and who could also organize some drivers for collecting the garbage from various parts of the city in the truck and pass on the city dumps or the recycling organizations. The second part was to make a system which could handle all the communications of all the people involved and could also maintain the data which will be collected while working around in the city.

Various bins were placed around the city which were provided with an embedded device which was low in price and helped in tracking the garbage level in the bins [5]. A different ID was provided to each bin so that it could be easier to detect that which is bin is full and ready to be emptied. The project is divided into two sections one being the transmitter section and other the receiver section. The transmitter section consists of a microcontroller and sensors which check the level of the garbage and the data is passed onto the system with the help of the RF Transmitter, then RF Receiver receives the data and sends it to the client associated so that the bin can be emptied quickly. Anitha et al (2016) proposed an home automation system using IOT uses raspberry for the implementation [6]. Also proposed a model for cyber security systems using artificial system to have secured transactions [7].

### 3. Materials and Methodology

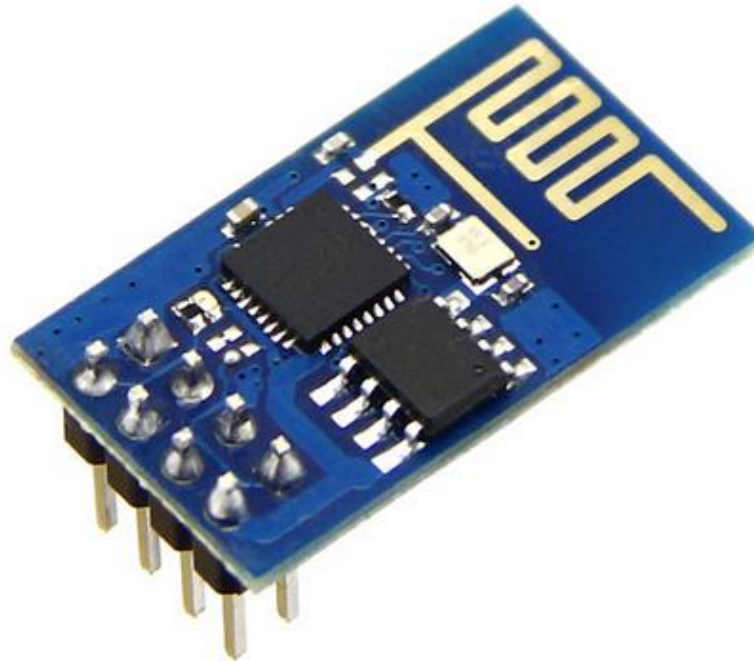


**Figure 1.** Arduino Uno

#### 3.1. Arduino Uno

Arduino is an open source, PC paraphernalia and programming organization, endeavour, and client group that plans and produce microcontroller packs for constructing programmed devices and intelligent object that can detect and control questions in the real world. The inception of the Arduino extend began at the Interaction Design Institute in Ivrea, Italy. The equipment reference plans are appropriated under a Creative Commons Attribution Share. Arduino Uno is shown in figure 1.

### 3.2. ESP8266 (Wi-Fi Module)



**Figure 2.** ESP8266.

ESP8266 is a Wi-Fi module which will give your projects access to Wi-Fi or internet. It is a very cheap device but it will make your projects very powerful. It can communicate with any microcontroller and make the projects wireless. It is in the list of most leading devices in the IOT platform. It runs on 3.3V and if you will give it 5V then it will get damage. The ESP8266 has 8 pins; the VCC and CH-PD will be connected to the 3.3V to enable the wifi. The TX and RX pins will be responsible for the communication of ESP8266 with the Arduino. The RX pin works on 3.3V so you will have to make a voltage divider for it as it used for implementation. ESP8266 is shown in figure 2

### 3.3. Ultrasonic Sensor

The Ultrasonic Sensor is used to measure the distance with high accuracy and stable readings. It can measure distance from 2cm to 400cm or from 1 inch to 13 feet. It emits an ultrasound wave at the frequency of 40KHz in the air and if the object will come in its way then it will bounce back to the sensor. By using that time which it takes to strike the object and comes back, you can calculate the distance. Distance can be measured by equation 1.

$$\text{Distance} = \text{Time} * \text{sound speed} / 2. \quad (1)$$

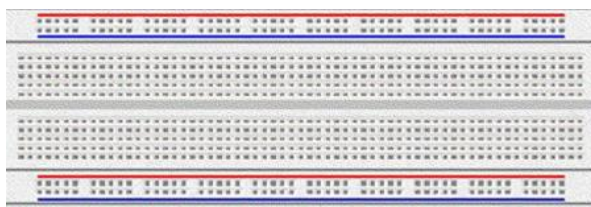
Where Time = the time between an ultrasonic wave is received and transmitted. It has four pins. Two are VCC and GND which will be connected to the 5V and the GND of the Arduino while the other two pins are Trig and Echo pins which will be connected to any digital pins of the Arduino. The trig pin will send the signal and the Echo pin will be used to receive the signal. To generate an ultrasound signal, you will have to make the Trig pin high for about 10us which will send a 8 cycle sonic burst at the speed of sound and after striking the object, it will be received by the Echo pin. Ultra sonic sensor as shown in figure 3.



**Figure 3.** Ultrasonic Sensor.

### 3.4. Bread board and Jump wires

A modern solderless breadboard consists of a perforated block of plastic with numerous tin plated phosphor bronze or nickel silver alloy spring clips under the perforations. The clips are often called tie points or contact points. The number of tie points is often given in the specification of the breadboard. The spacing between the clips (lead pitch) is typically 0.1 in (2.54 mm). Integrated circuits (ICs) in dual in-line packages (DIPs) can be inserted to straddle the centerline of the block. Interconnecting wires and the leads of discrete components (such as capacitors, resistors, and inductors) can be inserted into the remaining free holes to complete the circuit. Where ICs are not used, discrete components and connecting wires may use any of the holes. A breadboard is utilized to build and test circuits expeditiously afore finalizing any circuit design. The breadboard has many apertures into which route components like ICs and resistors can be connected.. A typical breadboard that includes top and bottom power distribution rails is shown below figure 4. Jump wires are generally used to establish connectivity with bread board as shown in figure 5.



**Figure 4.** Bread board.



**Figure 5.** Jump Wires.

## 4. Proposed System

The existing system has the limitations as time consuming, trucks go and empty the containers, even they are empty. The cost is high with unhygienic environment. Even the bad odour causes the unhealthy environment. So, proposed model talks about how to make use of the recent advancements in technology to make our place clean and tidy.

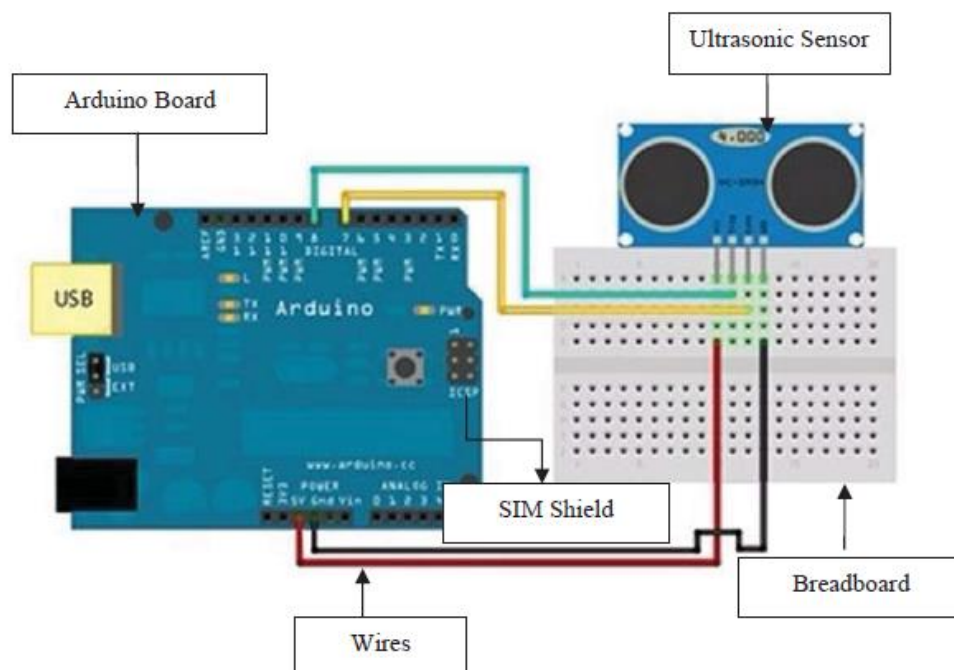
The implementation starts by setup ESP8266 by flashing the latest version of the firmware. This enable s the Blynk libraries efficiently communicate and avoid producing error.. To flash the latest firmware, download the ESP8266 flasher tool and the latest firmware from the internet which would be in the bin format and flash the ESP8266 with it. Once the ESP8266 flashing done, other components can be added to the configuration. we need a breadboard to

connect the microcontroller, ultra sonic sensor, buzzer and the ESP8266 using the jumper wires. The breadboard is used to interface between the various components available. It also makes it easy to connect multiple inputs to a single pin on the arduino board. The connection of hardware parts are shown in figure 6.

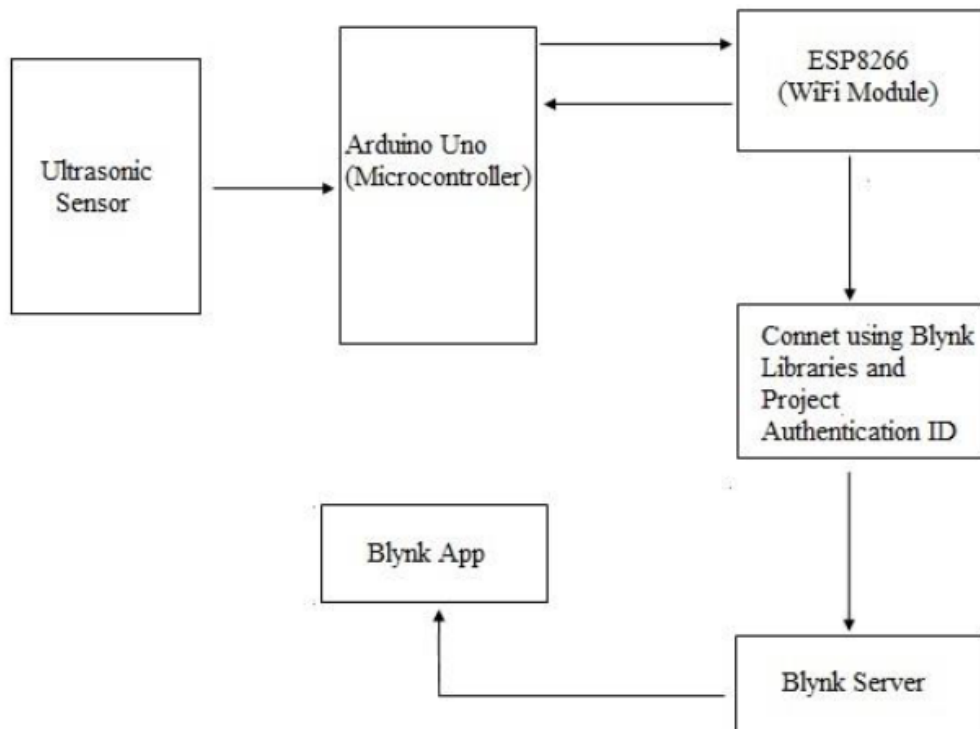


**Figure 6.** Hardware components connection.

Following sketch diagram as shown in Figure 7, shows how the components are supposed to be connected together using the breadboard and the jumper wires. The architecture diagram is shown in figure 8.



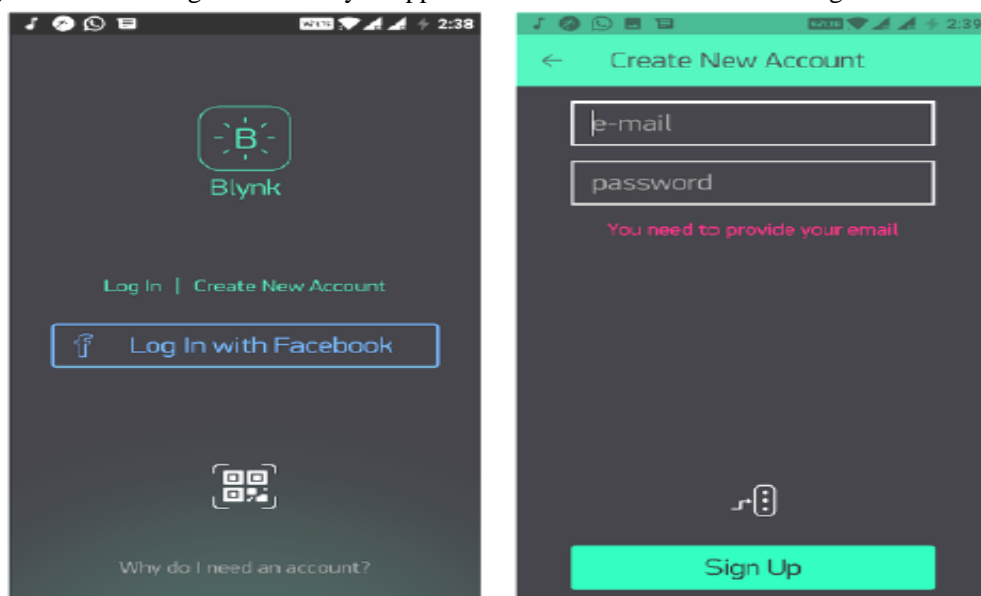
**Figure 7.** Sketch Diagram.



**Figure 8.** Proposed model - Architecture Diagram.

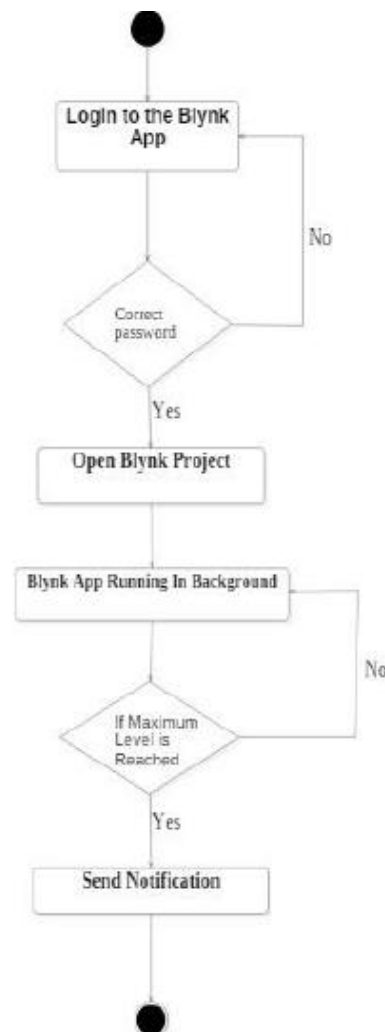
## 5. Configuring Blynk App

To connect to the internet we make use of a prebuilt platform called Blynk app. After the user installs the Blynk app on the smartphone, an account to be created in the app to access its services. The services are enabled for the signed users. Let us create an account and add a new project to get started. An unique authentication code is used by the code to communicate with the project. The Blynk needs to be running in the background for the user to get real time notifications. The working process of the proposed model can be clearly seen in the following figure 9. The configuration of Blynk app and account creation is shown in figure 10.



**Figure 9.** Configuration with Blynk app and account creation





**Figure 10.** Working process of the proposed model

### 5.1 Working Process

After the account creation, the arduino will first read the ultrasonic sensor, It will send the signal with the speed of sound. It revert back after striking the object and the travel time is store based on equation1. Thus the distance of the object is calculated. Based on the distance we can identify the garbage level to be low or high. We used the term “overflow” to indicate the necessary for cleaning process. Thus the mobile is enable with the term as “Overflow”.

Sample code is given below implemented in the proposed work.

Sample Code:

```

#define BLYNK_DEBUG
#define BLYNK_PRINT Serial
//Include ESP and Blynk libraries
#include <ESP8266_SoftSer.h>
#include <BlynkSimpleShieldEsp8266_SoftSer.h>
#include <SimpleTimer.h>
SimpleTimer timer;
// Set ESP8266 Serial object
#include <SoftwareSerial.h>
SoftwareSerialEspSerial(2, 3); // RX, TX
ESP8266 wifi(EspSerial);
  
```

```
const int trigPin = 8;
const int echoPin = 9;
char auth[] = "f07820f6001843bca8052d3ef336eade";
void setup() {
  Serial.begin(9600);
  // Set console baud rate
  Serial.begin(9600);
  delay(10);
  // Set ESP8266 baud rate
  // 9600 is recommended for Software Serial
  EspSerial.begin(9600);
  delay(10);
```

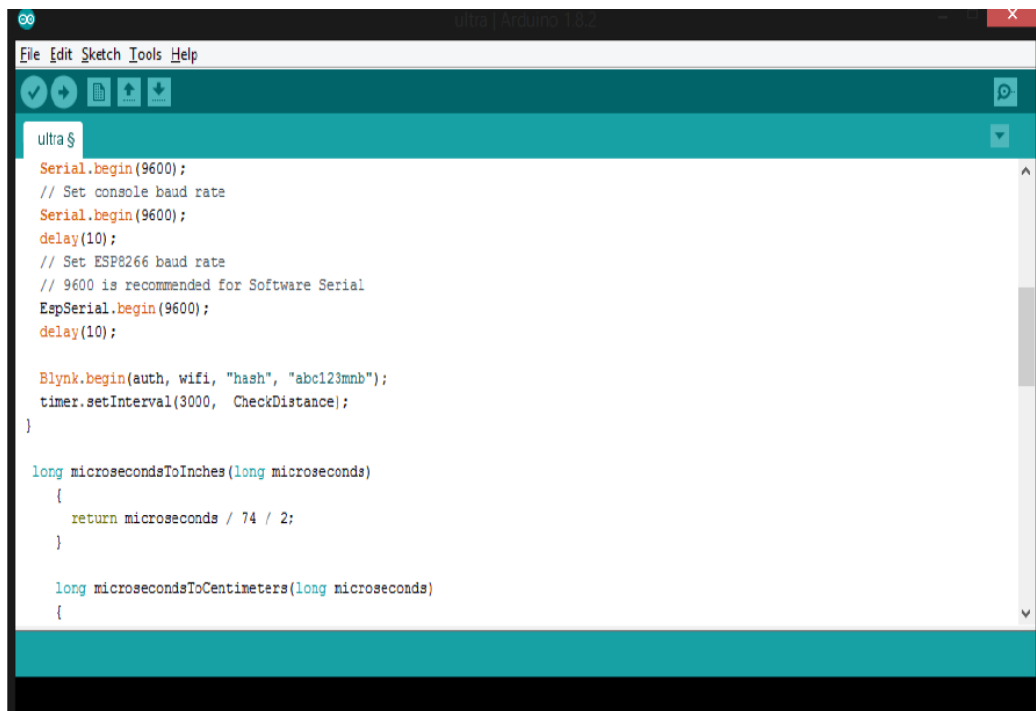
```
Blynk.begin(auth, wifi, "hash", "abc123mnb");
timer.setInterval(3000, CheckDistance);
}
```

```
.
.
.
```

```
void CheckDistance()
{
  long duration, inches;
  pinMode(trigPin, OUTPUT);
  digitalWrite(trigPin, LOW);
  delayMicroseconds(2);
  digitalWrite(trigPin, HIGH);
  delayMicroseconds(10);
  digitalWrite(trigPin, LOW);
  pinMode(echoPin, INPUT);
  duration = pulseIn(echoPin, HIGH);
  inches = microsecondsToInches(duration);
  cm = microsecondsToCentimeters(duration);
  Serial.print(inches);
  Serial.print("in ");
  Serial.println();
  Blynk.virtualWrite(V5, inches);
  //Check whether Bin is full or not
  if(inches < 2)
  {
```

```
Blynk.virtualWrite(V3, 255);
Blynk.notify(" Yaaay....Overflow!!");
}
delay(1000);
}
```

Once the code has been compiled, upload it to the Arduino Uno board by connecting the board to the computer using a 2.0 USB cable. The code for uploading is given in figure 11.



```

ultra $
Serial.begin(9600);
// Set console baud rate
Serial.begin(9600);
delay(10);
// Set ESP8266 baud rate
// 9600 is recommended for Software Serial
EspSerial.begin(9600);
delay(10);

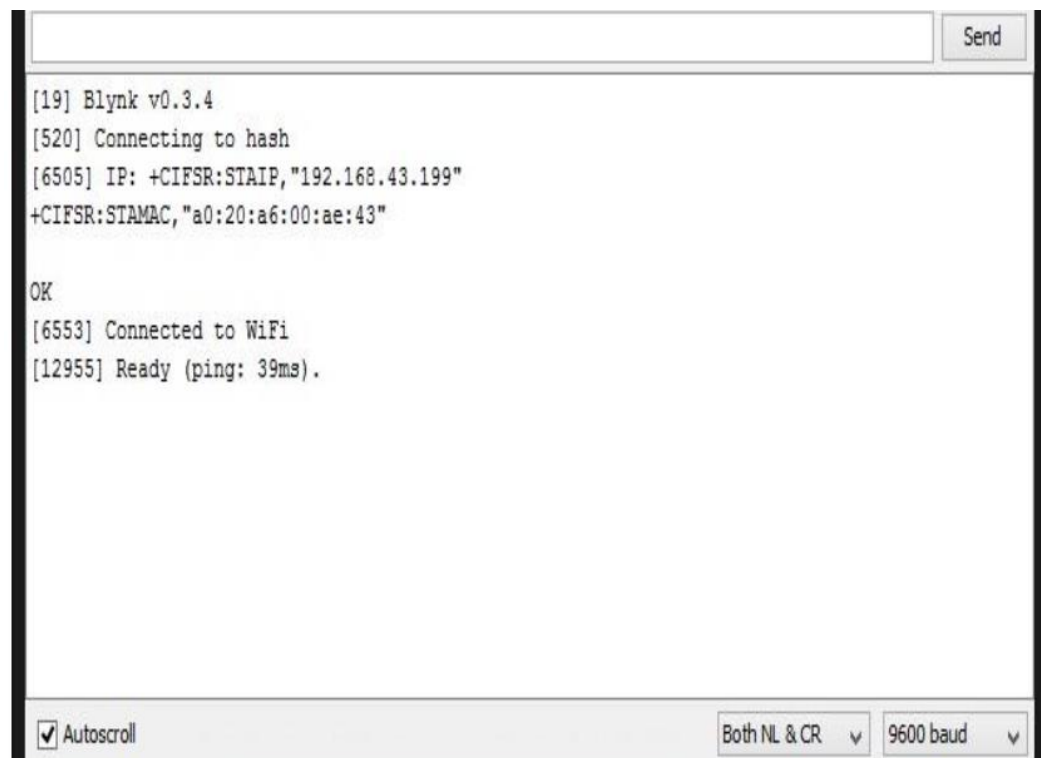
Blynk.begin(auth, wifi, "hash", "abc123mnb");
timer.setInterval(3000, CheckDistance);
}

long microsecondsToInches(long microseconds)
{
  return microseconds / 74 / 2;
}

long microsecondsToCentimeters(long microseconds)
{

```

**Figure 11.** Upload the code.



```

[19] Blynk v0.3.4
[520] Connecting to hash
[6505] IP: +CIFSR:STAIP,"192.168.43.199"
+CIFSR:STAMAC,"a0:20:a6:00:ae:43"

OK
[6553] Connected to WiFi
[12955] Ready (ping: 39ms).

```

Autoscroll  Both NL & CR  9600 baud

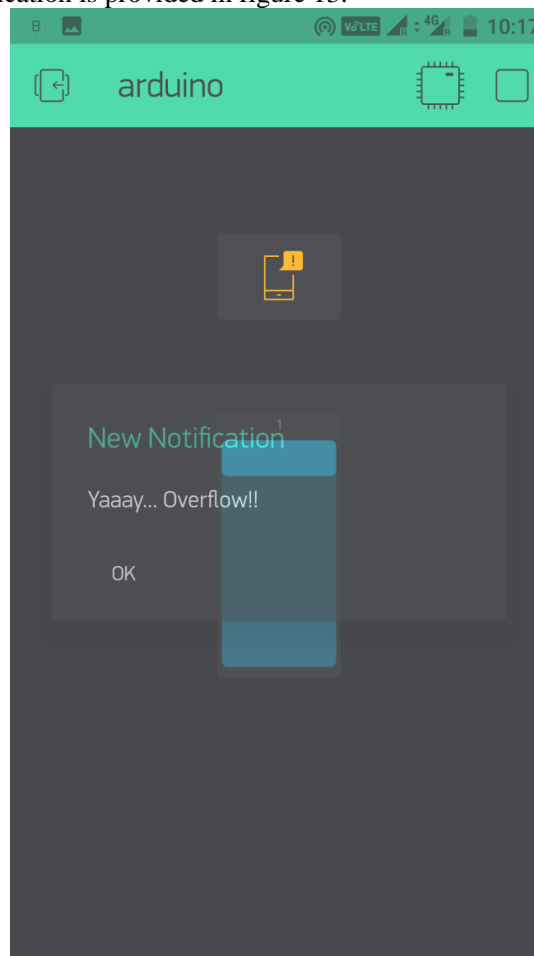
**Figure 12.** ESP8266 successfully connected to Blynk app.

After uploading the program click on “Serial monitor” to start running the code. Once the code starts to run, first thing it will do is to try and connect to ESP8266 to the access point pre-defined in the code. if the ESP8266 connects the model starts via the Blynk servers by

sending a ping message. The connection of ESP8266 with the Blynk app is shown in figure 12.

## 6. Experimental results

The system was checked repeatedly by increasing and decreasing the level of garbage in the bin. Notification was sent each time the level got changed. The user checked the notification was checked by the user on the blynk app, so it can be said that the system has worked in the way we planned. Proper security was also given to the hardware components so that the output which comes is accurate because further actions have to be taken based on the output. The result of the notification is provided in figure 13.



**Figure 13.** Experimental result.

## 7. Conclusion and Future Enhancement

The main objective is to maintain the level of cleanliness in the city and form an environment which is better for living. By using this system we can constantly check the level of the garbage in the dustbins which are placed in various parts of the city. If a particular dustbin has reached the maximum level then the employees can be informed and they can immediately take certain actions to empty it as soon as possible. The employees can check the status of these bins anytime on their mobile phones. This can prove to be a very useful system if used properly.

The system can be used as a benchmark by the people who are willing to take one step further for increasing the cleanliness in their respected areas. Ultrasonic sensor is being used

in this system to check the level of garbage in the dustbins but in future various other types of sensors can be used with the ultrasonic sensor to get more precise output and to take this system to another level. Now this system can be used in certain areas but as soon as it proves its credibility it can be used in all the big areas. As this system also reduces manual work certain changes can be done in the system to take it to another level and make it more useful for the employees and people who are using it. In future, a team can be made which will be in charge for handling and maintaining this system and also to take care of its maintenances.

## References

- [1] Monika K A, Rao N, Prapulla S B and Shobha G 2016 Smart Dustbin-An Efficient Garbage Monitoring System *International Journal of Engineering Science and Computing* **6** 7113-16
- [2] Navghane S S, Killedar M S and Rohokale D V 2016 IoT Based Smart Garbage and Waste Collection Bin *International Journal of Advanced Research in Electronics and Communication Engineering (IJARECE)* **5** 1576-78
- [3] Kasliwal Manasi H and Suryawanshi Smithkumar B 2016 A Novel approach to Garbage Management Using Internet of Things for smart cities *International Journal of Current Trends in Engineering & Research* **2** 348-53.
- [4] Medvedev A, Fedchenkov P, Zaslavsky A, Anagnostopoulos T and Khoruzhnikov S 2015 Waste management as an IoT-enabled service in smart cities *In Conference on Smart Spaces* Springer International Publishing 104-15
- [5] Schafer G 1994 *U.S. Patent No. 5,326,939*. Washington DC: U.S. Patent and Trademark Office.
- [6] Anitha A, Paul G and Kumari S 2016 A Cyber defence using Artificial Intelligence *International Journal of Pharmacy and Technology* **8** 25352-57
- [7] Anitha A, Kalra S and Shrivastav 2016 A Cyber defense using artificialhome automation system using IoT *International Journal of Pharmacy and Technology* **8** 25358-64