

Research Article

Grid-connected Switched Reluctance Generator based Wind Farm Control using Modified Hybrid Multicell Converter

¹R. Jayapragash and ²C. Chellamuthu

¹Anna University Chennai, Tamil Nadu, India

²Department of Electrical and Electronics Engineering, R.M.K. Engineering College, Tamil Nadu, India

Abstract: This study deals with analysis of grid integrated Switched Reluctance Generator (SRG) based wind farm control using Modified Hybrid Multicell Converter (MHMC). A Finite Element Analysis (FEA) model is developed for the existing machine geometry using MagNet 7.1.1 and solved to obtain the parameters like flux linkage, inductance and torque. The data obtained from FEA Model is utilized to develop model of SRG in the MATLAB/SIMULINK environment. Asymmetric Half Bridge Converter (AHBC) with dedicative buses for source and load is used for excitation. Developed wind turbine with Maximum Power Point Tracking (MPPT) algorithm to extract maximum power from the wind turbine. Output of the SRG is integrated with grid through Modified Hybrid Multicell Converter. The MHMC uses a flying capacitor module on each cell to generate a positive variable dc-link voltage. The variable dc link is inverted at fundamental switching frequency by an H-bridge to generate the cell output voltage. Phase-Disposition level-shifted Pulse Width Modulation (PD-PWM) Technique is used to obtain the high performance waveforms. In this study wind farm having four SRG'S controlled through MHMC is proposed.

Keywords: Asymmetric Half Bridge Converter (AHBC), Finite Element Analysis (FEA), Maximum Power Point Tracking (MPPT), Modified Hybrid Multicell Converter (MHMC), Switched Reluctance Generator (SRG)

INTRODUCTION

A Switched Reluctance Generator (SRG) is very simple in construction associated with the absence of permanent magnets or windings in the rotor, which results in lower manufacturing costs and makes it suitable for variable speed applications, Boldea (2006). Structure of the machine and unipolar power converter topology used are very robust. Switched Reluctance Generator is a very good alternative to conventional variable speed drives in many applications, especially in the extraction of maximum energy in wind energy generation system with the variable wind speeds, Sawata (2001).

Cornea *et al.* (2008) proposed a Switched Reluctance Motor drive model in the MATLAB/SIMULINK environment using standard library components. This work is studied to develop Switched Reluctance Generator drive model using library components and data obtained from FEA model.

Operation of SRG and its control is addressed by Torrey (2002). Operating variables are identified from this paper and it is used to control the grid-connected SRG based wind energy conversion system.

Chang and Liaw (2008) reported the design of power circuit and control scheme for SRG. Authors proposed power circuit with common bus for source

and load. This work is studied and extended to develop asymmetric half bridge converter with dedicative buses for source and load to avoid absorbing large current from the source.

Speed control of grid-connected switched reluctance generator driven by variable speed wind turbine using adaptive neural network controller is proposed by Hasanien and Mueen (2012). This study is referred to integrate SRG with grid.

Chang and Liaw (2011) reported switched reluctance generator based common DC microgrid system. In this study wind farm having four SRG's controlled through MHMC is proposed.

Lezana and Aceiton (2011) introduced new Hybrid Multicell Converter (HMC) (Lezana *et al.*, 2013). This topology is based on the series connection of macrocells which are composed by a flying capacitor converter that generates a variable dc-link voltage and an H-bridge that applies this voltage to the load with positive or negative polarity. The HMC topology is modulated with a simple Phase-Shifted Pulse Width Modulation (PS-PWM) scheme.

Phase-Disposition Pulse Width Modulation (PD-PWM) scheme is implemented for a HMC to obtain the high-performance by Lezana *et al.* (2013).

In this study analysis of Grid-Connected Switched Reluctance Generator Based Wind Farm Control using Modified Hybrid Multicell Converter is discussed and results are reported.

METHODOLOGY

Switched reluctance generator: Switched Reluctance Generator is an electromechanical device which converts mechanical energy into electrical energy by properly synchronizing phase current with rotor position. To achieve generating mode operation phase current pulses are applied during the period where the rotor leaves the aligned position and phase winding is excited by means of DC source bus. During generation, SRG produces negative torque that tends to oppose rotation, thereby extracts energy from the wind turbine (Torrey, 2002). The cross section of the 1 Hp, 4 phases, 8/6 SRG is shown in Fig. 1. Specifications of the SRG are given in Table 1.

The supporting diagram which explains the generating mode operation of the machine is shown in Fig. 2.

One arm of the power converter used to excite the phase winding of SRG is shown in Fig. 3. Dynamic equation of the phase voltage (v) is given as:

$$v = iR + \frac{d\lambda(i, \theta)}{dt} \tag{1}$$

where,

v = DC source voltage

λ = Flux linkage

R = Resistance of the phase winding

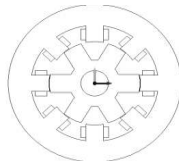

Fig. 1: Cross section of SRG

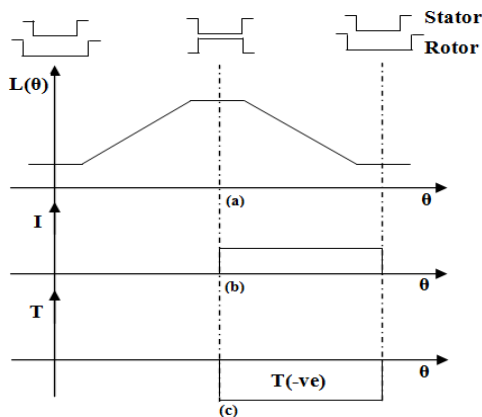

Fig. 2: (a) Ideal inductance profile, (b) current pulse, (c) torque

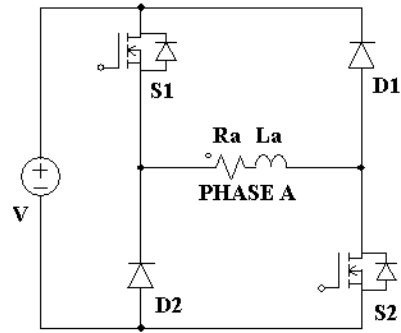

Fig. 3: One arm of the power converter

Table 1: Specifications of SRM

Electrical specifications of SRM	
Rated power	1 Hp (746 w)
Rated speed	3000 RPM
Rated voltage	330 V, DC
Rated current	5 A
Construction and mechanical specifications	
Winding gauge	24 SWG
No. of turns per pole	100 turns
Stator core stamping thickness	0.5 mm
Rotor core stamping thickness	0.5 mm
Shaft diameter	14 mm
Thickness of rotor yoke	5.8 mm
Height of rotor pole	10 mm
Air gap length	0.2 mm
Height of stator pole	9 mm
Thickness of stator yoke	11.5 mm
Stack length	80 mm
Stator pole arc	22°
Rotor pole arc	25°
Material used CRNGO grade M-19	

The flux linkage (λ) is a function of current (i) and rotor position (θ), therefore the voltage equation can be rewritten as Chang and Liaw (2008):

$$v = iR + L \frac{di}{dt} + iw \frac{dL}{dq} \tag{2}$$

Considering one phase of the converter, during magnetization period both switches S1 and S2 connect the DC bus to the winding, thus the phase current increases. Equation corresponding to excitation is described as:

$$v = i_{exc} R + L \frac{di_{exc}}{dt} - |e| \tag{3}$$

where,

i_{exc} = Current during excitation

L = Inductance, function of current (i) and rotor position (θ)

e = Back emf

During generation both switches S1 and S2 are OFF, then the DC bus is connected in reverse polarity

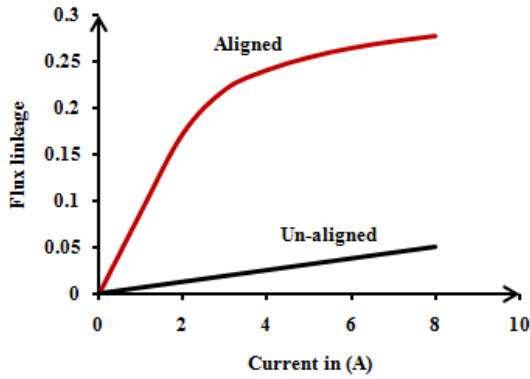

Fig. 4: Flux linkage vs. current

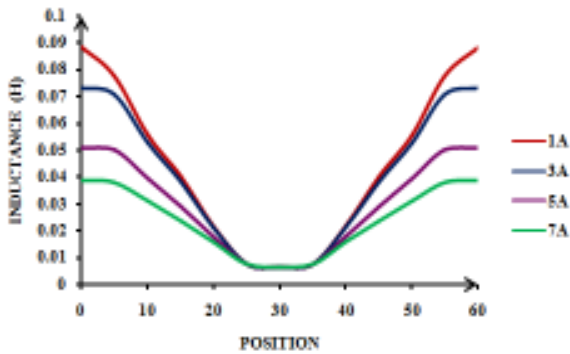

Fig. 5: Inductance profile

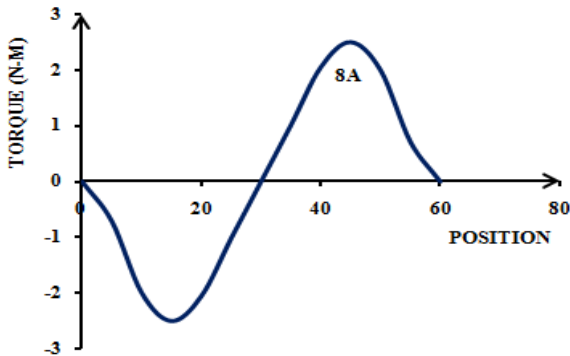

Fig. 6: Torque characteristics

through the diodes D1 and D2. Consequently, the phase current flows back to the DC bus and return the generated power to it. Equation corresponding to generation is represented as:

$$-v = i_{gen}R + L \frac{di_{gen}}{dt} - |e| \quad (4)$$

where,

i_{gen} = Current during generation

A Finite Element Analysis (FEA) model is developed for the existing machine geometry using

MagNet 7.1.1 and solved to obtain the parameters like flux linkage, inductance and torque.

The variation of flux linkage with respect to current is shown in Fig. 4.

It is evident from Fig. 5 that inductance is maximum at the aligned position. When the rotor leaves the aligned position inductance decreases and it is minimum at the unaligned position. The inductance profile of the machine is periodic function of rotor position as seen in Fig. 5.

Torque obtained from FEA model for various values of current and position is shown in Fig. 6. It is negative from 0-30° and positive from 30-60°.

Wind turbine modeling: Wind Turbine (WT) is a machine for converting the kinetic energy in the wind into mechanical energy. The kinetic energy in a flow of air through a unit area perpendicular to the wind direction, per mass flow rate is computed as (Chen *et al.*, 2013; Khanna *et al.*, 2014):

$$E = \frac{1}{2}v^2 \quad (5)$$

where,

v = Wind speed (m/sec)

For an air stream flowing through an area 'A' the mass flow rate is ρAv , therefore the power in the wind is given as:

$$P_w = \frac{1}{2} \rho A v^3 \text{ (watts or J/sec)} \quad (6)$$

where,

ρ = Air density = 1.225 kg/m³

A = Area covered by blades, m²

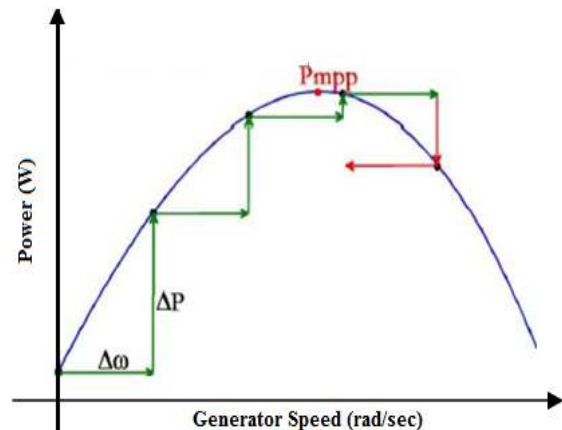

Fig. 7: Principle of hill climb search control

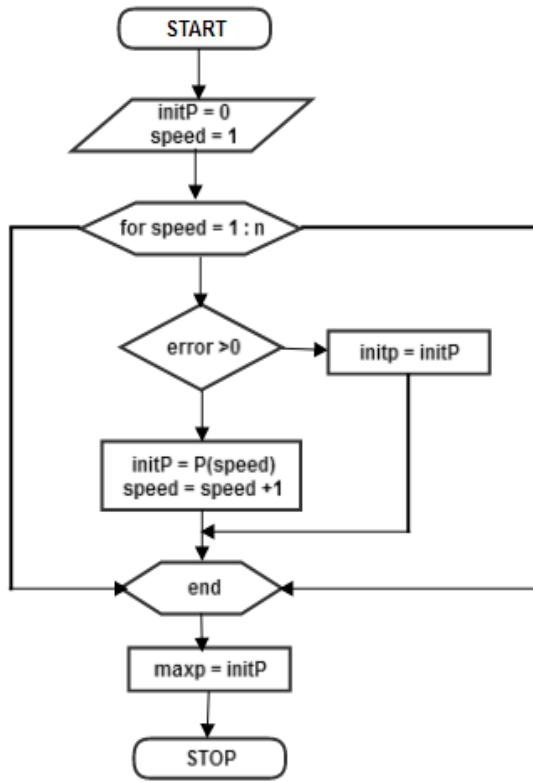

Fig. 8: Flow chart for MPPT

The co-efficient of performance (C_p) is defined as the fraction of energy extracted by the wind turbine of the total energy that would have flowed through the area swept by the rotor if the turbine had not been there. The expression for co-efficient of performance (C_p) is described as:

$$C_p(l, b) = \frac{P_{extracted}}{P_w} \quad (7)$$

C_p has a maximum theoretical value of 0.593.

where,

$P_{extracted}$ = Power extracted by the wind turbine and it is expressed as:

$$P_{extracted} = C_p(l, b) \frac{1}{2} r A v^3 \quad (8)$$

where,

λ = Tip speed ratio and it is given as $\lambda = \frac{\omega R}{v}$

ω = Rotor speed, rad/sec

R = Rotor radius (blade length), m

β = Pitch angle, degrees

The rotor torque T_w is given as:

$$T_w = \frac{1}{2} \rho C_p(l, b) r R^2 v^3 \quad (9)$$

The maximum power extractable from the wind turbine depends not only on the strength of the source but also on the operating point of the energy conversion system. Therefore the Maximum Power Point Tracking (MPPT) is of the principal significance in wind energy conversion systems. Wind farm with MPPT algorithm is developed to optimize the generator speed relative to the wind velocity intercepted by the wind turbine such that the power is maximized. MPPT techniques mainly used are:

- The lookup table based
- The state space linearization and non-linear state space based
- The neural network and fuzzy logic based
- The hill climbing based
- Hybrid technique

Among these methods hill climb search control is feasible method and it does not require prior knowledge of the system. The principle of hill climb search control is, keep perturbing the control variable in the same direction until the power is decreased as shown in Fig. 7.

The flow chart for hill climb search law is shown in Fig. 8.

Coding is developed in MATLAB to obtain the response of Wind Turbine (WT) with MPPT capability. The Wind Turbine characteristic for variable speed operation is shown in Fig. 9.

RESULTS AND DISCUSSION

Simulation model of converter and SRG: The converter used for the SRG is shown in Fig. 10. Asymmetric Half Bridge Converter with dedicative buses for source and load is used to avoid absorbing more current from the source. To get generator mode operation, winding is energized during the drooping inductance region of the inductance profile, where the variation of inductance with respect to the rotor position is negative. The sign of the generated torque is negative and it extracts energy from the wind turbine.

The equivalent model of SRG is a set of differential equations obtained using dynamic electric machine theory. The flux linkage Vs current, inductance Vs rotor position and torque characteristics of the machine are obtained using FEA. The electrical model of the SRG is created and linked to the mechanical model.

The SRG is modeled as an inductor and a resistor in series as shown in Fig. 3. The phase of SRG is modeled according to Eq. (1) in SIMULINK. The

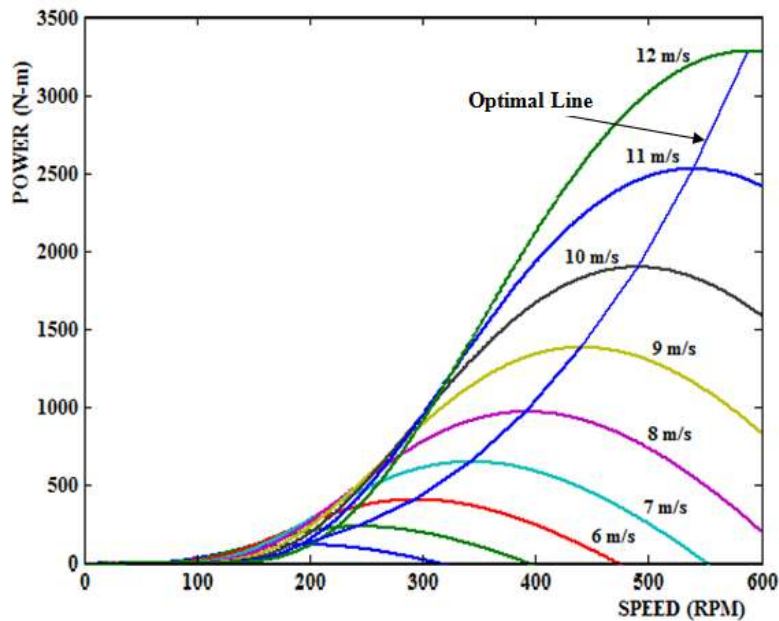

Fig. 9: Wind turbine characteristics

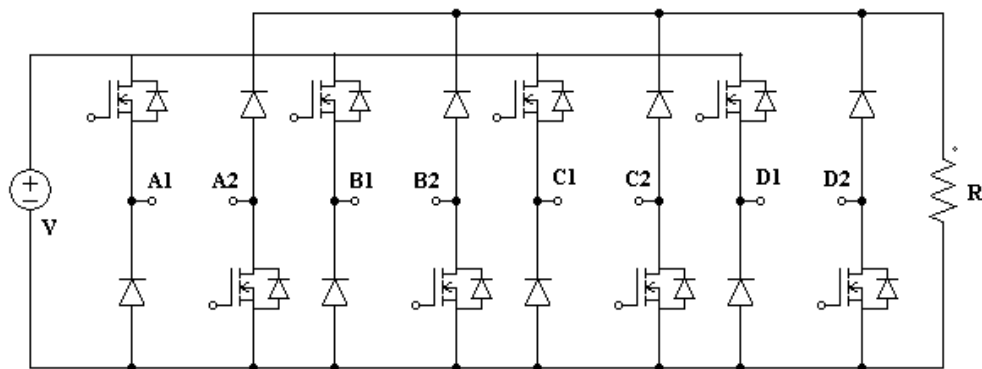

Fig. 10: Asymmetric half bridge converter

model is composed by several modules such as position sensor, power converter, controller and phase winding.

MATLAB/SIMULINK model of SRG is shown in Fig. 11. Phase windings of the SRG are excited in a sequential manner and the torque contributed by the individual phases are summed up to obtain the total Torque (T) developed by the machine. Dynamic equation is solved in the mechanical block to obtain speed and rotor position.

Simulation results of the SRG are reported below. For 4-phases 8/6 SRG, minimum dwell angle is 15° and maximum dwell angle is 30° . The results are obtained for $\theta_{on}=5^\circ$ and $\theta_{off}=30^\circ$. Figure 12 gives generated voltage of the SRG.

Phase current of the generator mode operation is shown in Fig. 13. The sign of the current is always positive due to the unidirectional elements present in the converter.

SRG generates negative torque and it is shown in Fig. 14.

Modified hybrid multicell converter: Conventional two-level inverters are mostly used to generate an AC voltage from a DC voltage. The two-level inverter can only create two different output voltages for the load. To build up an AC output voltage these two voltages are usually switched with PWM. Though this method is effective it creates harmonic distortions in the output voltage, EMI and high dv/dt .

The concepts of Multilevel Inverters (MLI) do not depend on just two levels of voltage to create an AC signal. Instead several voltage levels are added to each other to create a smoother stepped waveform, with lower dv/dt and harmonic distortions. With more voltage levels in the inverter the waveform it creates becomes smoother, but with many levels the design becomes more complicated, with more components and a more complicated controller for the inverter is needed.

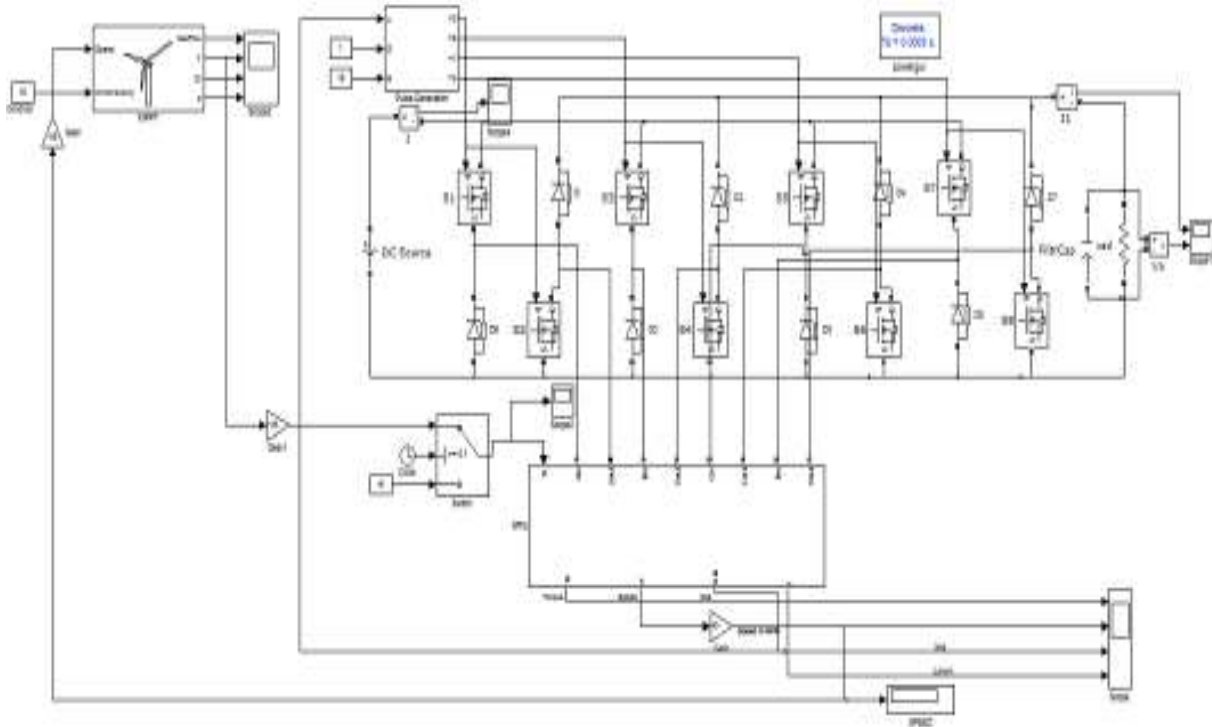

Fig. 11: MATLAB/SIMULINK model of SRG

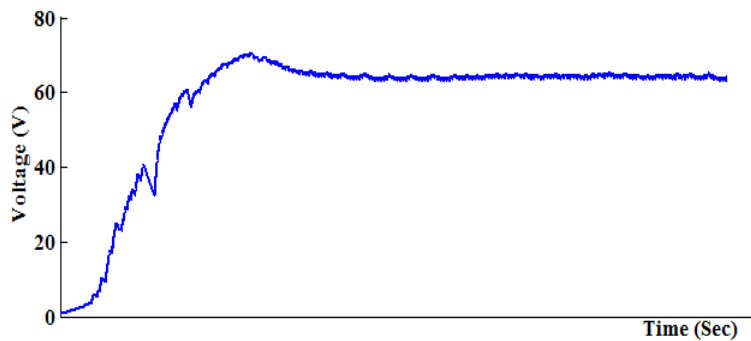

Fig. 12: Generated voltage of SRG

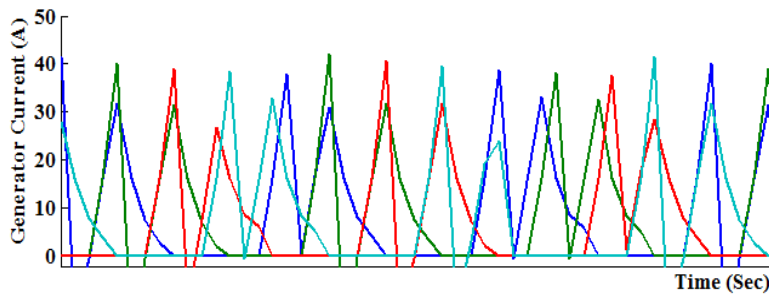

Fig. 13: Current response of SRG

The hybrid topologies merged two or more classical topologies in order to improve the output waveforms, reduce the number of semiconductors, reduce the losses, reduce the supply requirements, etc.

The HMC is a new modular multilevel topology proposed by Lezana and Aceiton (2011) and shown in Fig. 15. The HMC uses a flying capacitor module on each cell to generate a positive variable dc-link voltage.

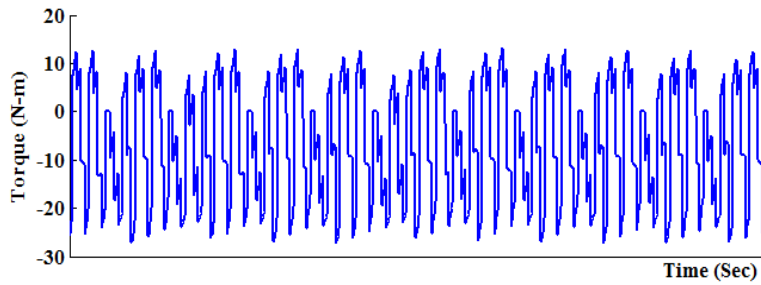

Fig. 14: Torque response of SRG

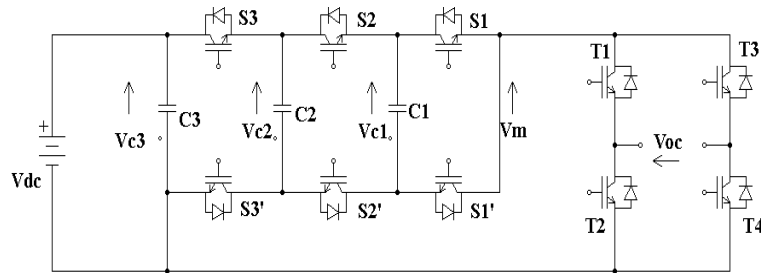

Fig. 15: Seven level HMC

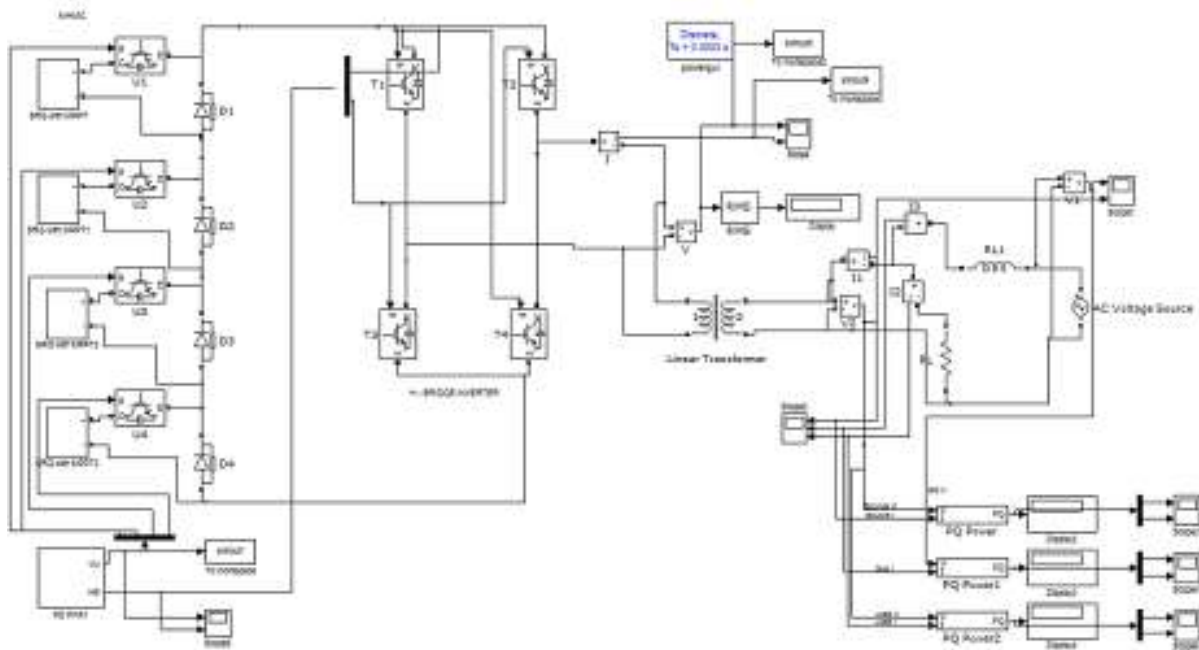

Fig. 16: MATLAB/SIMULINK model of MHMC

The variable dc link is inverted at fundamental switching frequency by an H-bridge to generate the cell output voltage. Phase-Disposition level-shifted Pulse Width Modulation (PD-PWM) Technique is used to obtain the high performance waveforms, (Lezana *et al.*, 2013). The macrocell multilevel dc-link voltage V_m is implemented by the FC converter, which is handled by the output H-bridge to generate the cell output signal V_{oc} .

HMC topology shown in Fig. 15 is customized to obtain Modified Hybrid Multicell Converter (MHMC). MHMC allows additional SRG's to be connected in series, increasing the overall converter voltage and power ratings while improving the quality of the output signals. In this study wind farm having four SRG'S controlled through MHMC is proposed. MATLAB/SIMULINK model of the grid-connected SRG based wind farm control using MHMC is shown in Fig. 16.

Switching state and output voltage of MHMC is given in Table 2.

Switching signals for the MHMC is derived using Phase-Disposition level-shifted Pulse Width Modulation (PD-PWM) Technique. It is a technique used to obtain high performance output. Wind farm

proposed in this study is having four SRG, therefore four triangular carriers are used and which are compared with sinusoidal. Modulation signals are shown in Fig. 17.

Switching Signals for the MHMC and H-bridge inverter are shown in Fig. 18 and 19, respectively.

Table 2: Switching state and output voltage

Output	U1	U2	U3	U4	D1 to D4	T1	T4	T2	T3
+1Vdc	On	x	x	x	OFF (RB)	On	On	x	x
+2Vdc	On	On	x	x		On	On	x	x
+3Vdc	On	On	On	x		On	On	x	x
+4Vdc	On	On	On	On		On	On	x	x
0	x	x	x	x		x	x	x	x
-1Vdc	On	x	x	x		x	x	On	On
-2Vdc	On	On	x	x		x	x	On	On
-3Vdc	On	On	On	x		x	x	On	On
-4Vdc	On	On	On	On		x	x	On	On

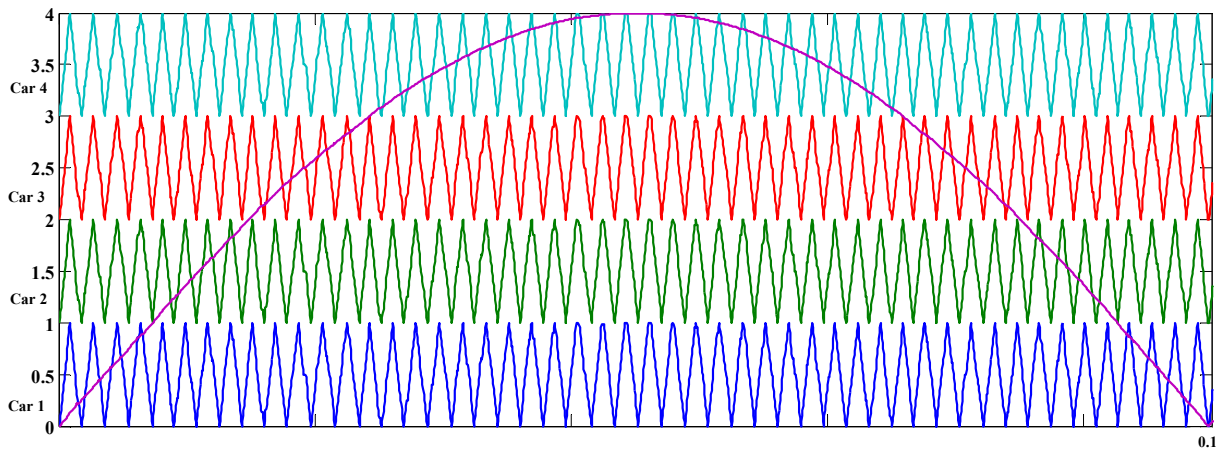

Fig. 17: Modulation signals

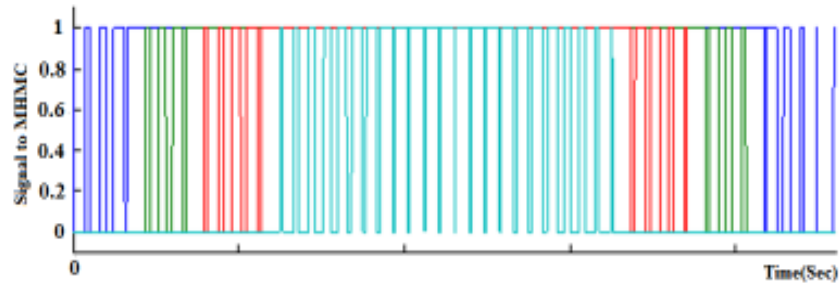

Fig. 18: Switching signals for MHMC

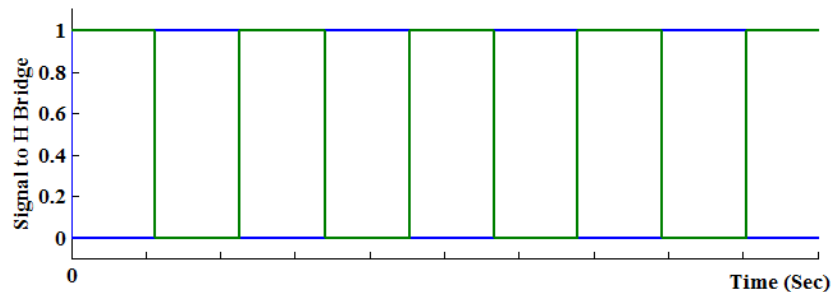

Fig. 19: Switching signals for H bridge inverter

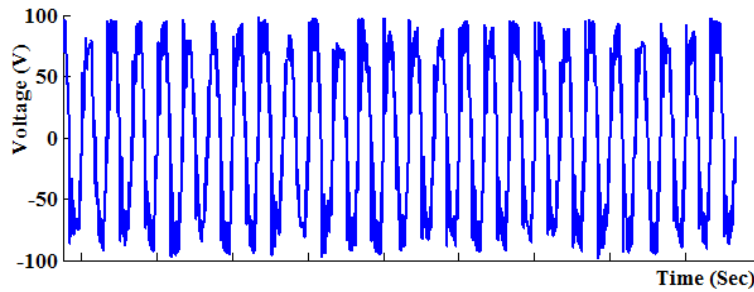

Fig. 20: Output voltage response of MHMC

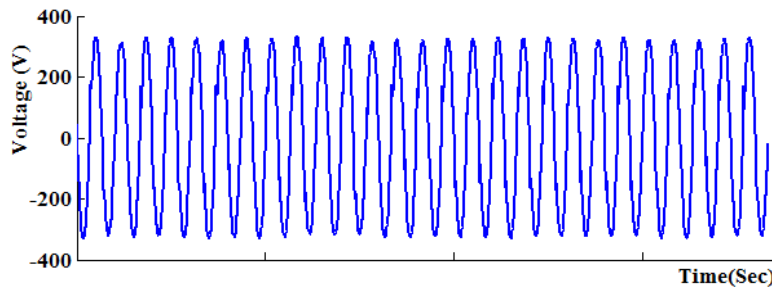

Fig. 21: Voltage across the load connected to grid

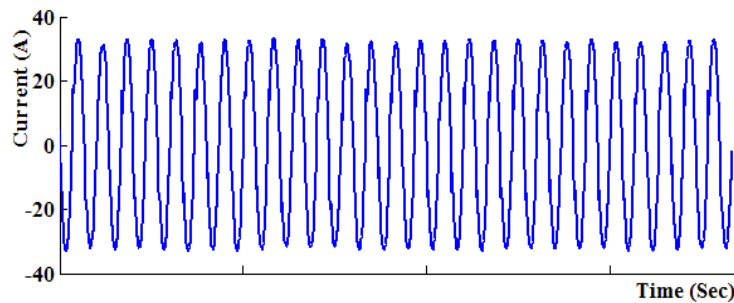

Fig. 22: Current through the load connected to grid

The output voltage response of the MHMC is shown in Fig. 20. There is a small distortion in the output voltage due to the non-linearity that exists in the SRG.

The output of the MHMC is integrated to the grid through a transformer to match the voltage and frequency of the SRG with the grid. Voltage and current waveforms of the load which is integrated with the grid are shown in Fig. 21 and 22.

From the results, it is clear that the wind farm having four SRG's is properly integrated with the grid. The SRG gives satisfactory performance in the generating mode and supplies power to the load. From the above discussion, it is very apparent that the SRG is a very good wind generator for a wind energy conversion system and a modified hybrid multicell converter is suitable for wind farm control.

CONCLUSION

This paper has presented a grid-connected switched reluctance generator-based wind farm control using

modified hybrid multicell converter. A developed SRG machine model in the MATLAB/SIMULINK environment using the data obtained from the FEA model and the response of the SRG is found satisfactory. A wind turbine model with Maximum Power Point Tracking (MPPT) algorithm is developed to extract maximum power from the wind turbine. The switching signal for triggering the power device in the MHMC is obtained accurately using Phase-Disposition level-shifted Pulse Width Modulation (PD-PWM) Technique and the operation of MHMC is found reasonable. The output of the MHMC is integrated to the grid through a transformer to match the voltage and frequency of the SRG with the grid. Results are reported and this wind farm is suitable for rural electrification.

REFERENCES

Boldea, I., 2006. Variable Speed Generators. Taylor and Francis Group, LLC, CRC.

- Chang, Y.C. and C.M. Liaw, 2008. On the design of power circuit and control scheme for switched reluctance generator. *IEEE T. Power Electr.*, 23(1).
- Chang, Y.C. and C.M. Liaw, 2011. Establishment of a switched-reluctance generator-based common DC microgrid system. *IEEE T. Power Electr.*, 26(9): 2512-2527.
- Chen, J., J. Chen and C. Gong, 2013. Constant-bandwidth maximum power point tracking strategy for variable-speed wind turbines and its design details. *IEEE T. Ind. Electron.*, 60(11): 5050-5058.
- Cornea, O. and D. Popovici and A. Argeseanu, 2008. A switched reluctance motor drive model using standard simulink library components. *Proceeding of 11th International Conference on Electrical and Electronic Equipment (OPTIM, 2008)*, pp: 69-74.
- Hasanien, H.M. and S.M. Muyeen, 2012. Speed control of grid-connected switched reluctance generator driven by variable speed wind turbine using adaptive neural network controller. *Electr. Pow. Syst. Res.*, 84: 206-213.
- Khanna, R., Q. Zhang, W.E. Stanchina, G.F. Reed and Z.H. Mao, 2014. Maximum power point tracking using reference adaptive control. *IEEE T. Power Electr.*, 29(3): 1490-1499.
- Lezana, P. and R. Aceiton, 2011. Hybrid multicell converter: Topology and modulation. *IEEE T. Ind. Electron.*, 58(9): 3938-3945.
- Lezana, P., R. Aceiton and C. Silva, 2013. Phase-disposition PWM Implementation for a hybrid multicell converter. *IEEE T. Ind. Electron.*, 60(5): 1936-1942.
- Sawata, T., 2001. *Electronic Control of Switched Reluctance Machines*. Reed Educational and Professional Publishing Ltd., pp: 227-251.
- Torrey, D.A., 2002. Switched reluctance generators and their control. *IEEE T. Ind. Electron.*, 49(1): 3-14.