



# Investigating the structural impacts of a novel missense variant identified with whole exome sequencing in an Egyptian patient with propionic acidemia



Ali Zaki Ibrahim<sup>a</sup>, D. Thirumal Kumar<sup>b</sup>, Taghreed Abunada<sup>d</sup>, Salma Younes<sup>d</sup>,  
C. George Priya Doss<sup>b</sup>, Osama K. Zaki<sup>c,\*</sup>, Hatem Zayed<sup>d,\*</sup>

<sup>a</sup> Faculty of Medicine, Ain Shams University, Cairo, Egypt

<sup>b</sup> School of BioSciences and Technology, Vellore Institute of Technology, Vellore, Tamil Nadu, India

<sup>c</sup> Medical Genetics Unit, Pediatric Department, Faculty of Medicine, Ain Shams University, Cairo, Egypt

<sup>d</sup> Department of Biomedical Sciences, College of Health Sciences, QU Health, Qatar University, Doha, Qatar

## ARTICLE INFO

### Keywords:

Propionic acidemia (PA)

PCCA gene

Next-generation sequencing

Computational analysis

Genotype-phenotype correlation

## ABSTRACT

Propionic Acidemia (PA) is an inborn error of metabolism caused by variants in the *PCCA* or *PCCB* genes, leading to mitochondrial accumulation of propionyl-CoA and its by-products. Here, we report a 2 year-old Egyptian boy with PA who was born to consanguineous parents. Biochemical analysis was performed using tandem mass spectrometry (MS/MS) on the patient's dried blood spots (DBS) followed by urine examination of amino acids using gas chromatography/mass spectrometry (GC/MS). Molecular genetic analysis was carried out using whole-exome sequencing (WES). The *PCCA* gene sequencing revealed a novel homozygous missense variant affecting the locus (chr13:100962160) of exon 16 of the *PCCA* gene, resulting in the substitution of the amino acid arginine with proline at site 476 (p.Arg476Pro). Computational analyses revealed that the novel variant might have a pathogenic effect that attributed to decreased protein stability, and also has an effect on the biotin carboxylase c-terminal domain of the propionyl carboxylase enzyme. The physicochemical properties analysis using NCBI amino acid explorer study revealed restrictions in the side chain and loss of hydrogen bonds due to the variant. On the structural level, the loss of beta-sheet was observed due to the variant proline, which has further led to the loss of surrounding interactions. This loss of beta-sheet and the surrounding interactions might serve the purpose of the structural stability changes. The current study demonstrates that the combination of whole-exome sequencing (WES) and computational analysis are potent tools for validation of diagnosis and classification of disease-causing variants.

## 1. Introduction

Propionic Acidemia (PA) (MIM # 606054) is an autosomal recessive metabolic disorder caused by a deficiency in the activity of the propionyl-CoA carboxylase (PCC) enzyme. The PCC enzyme catalyzes the carboxylation of propionyl-CoA to methylmalonyl-CoA. It is encoded by the *PCCA* (MIM# 232000) and *PCCB* (MIM# 232050) genes to form a 750 kDa heterododecamer composed of  $\alpha$ - and  $\beta$ -subunits, respectively [1]. Bi-allelic variants that diminish or abolish the function of *PCCA* or *PCCB* subunits result in accumulation of propionic acid and propionyl-CoA related metabolites, which are known to be toxic for the brain, heart, muscles, and liver [2,3]. Such accumulation of intermediate metabolites impacts the anaplerotic replenishment of TCA intermediates, the oxidative phosphorylation, and many other metabolic

pathways [1].

Symptoms of PA may begin as early as the first day postpartum but can be delayed for months or years. For neonates, the classical clinical presentation consists of vomiting, dehydration, weight loss, temperature instability, neurological involvement with muscular hypo- or hypertonia, irritability, lethargy progressing to coma, seizures, and death, if untreated. However, symptoms after the neonatal period are non-specific and might mimic many other common disorders [4]. At presentation, laboratory findings include severe and persistent metabolic acidosis with an elevated anion gap, hyperammonemia, hyperglycinemia, and hyperglycinuria [4]. Diagnosis is made by mass spectrometry for acylcarnitines in the blood showed elevated C3-carnitine and C3-/C2-carnitine ratio, and gas chromatography for organic acids in urine showed increased in urine excretion of methyl citrate and 3-

\* Corresponding authors.

E-mail addresses: [ozaki@med.asu.edu.eg](mailto:ozaki@med.asu.edu.eg) (O.K. Zaki), [hatem.zayed@qu.edu.qa](mailto:hatem.zayed@qu.edu.qa) (H. Zayed).

<https://doi.org/10.1016/j.ymgmr.2020.100645>

Received 3 August 2020; Received in revised form 24 August 2020; Accepted 24 August 2020

Available online 17 September 2020

2214-4269/© 2020 The Authors. Published by Elsevier Inc. This is an open access article under the CC BY license (<http://creativecommons.org/licenses/by/4.0/>).

hydroxy-propionate.

According to the Human Gene Mutation Database [5], a total of 207 variants in both *PCCA* and *PCCB* genes have been identified to date. The mutational spectrum is clearly population-specific, and some variants have been found to be exclusively associated with specific geographical or ethnic groups. For instance, the 1218del14ins12 (ins/del) is the most common variant among Caucasians [6,7]. The mutation p.T428I is reported frequently among Japanese and Korean PA patients [8–10]. For both *PCCA* and *PCCB* genes, missense variants are known to be the most frequent defects (43% and 58%, for *PCCA* and *PCCB*, respectively), followed by small insertions/deletions and splicing variants, most of them result in a truncated protein [5]. The variants are distributed all along with the gene sequences. However, some clustering is observed in exon 13 in the *PCCA* gene, and in exons 12 and 15 in the *PCCB* gene, implying that they could be hot spots for variants or involved in critical functional domains.

In this study we used NGS to identify a novel variant in a 2 year-old Egyptian boy with PA, who was born to consanguineous parents. This novel variant was further subjected to computational analysis to predict the pathogenicity and stability changes in the protein due to the occurrence of a novel variant in the *PCCA* gene.

## 2. Materials and methods

### 2.1. Ethics statement

This study was approved by the Institutional Review Boards (IRB) of Ain Shams University, and adhered to the ethical guidelines of the Declaration of Helsinki and its amendments. Informed consent was acquired from the parents of the proband after a detailed explanation of the purpose of the study.

### 2.2. Biochemical analysis

#### 2.2.1. Tandem mass spectrometry (MS/MS)

A blood sample was taken from the patient through a finger prick on the Guthrie card (Whatman 903 filter paper (GE Healthcare, New Jersey, USA). The blood spots were analyzed for acylcarnitines and amino acids by a triple-quadrupole tandem mass spectrometer (ACQUITY UPLC H-Class. Waters® corporation, Massachusetts, USA), with a positive electrospray ionization probe, utilizing Mass Chrom® Amino acids and Acylcarnitines from Dried Blood kit (Chromsystems Instruments & Chemicals GmbH, München, Germany) according to manufacturer's instructions. The data of the MRM scan were analyzed using Neolynx® application (Waters® Corporation, Massachusetts, USA).

#### 2.2.2. Gas chromatography/ mass spectrometry (GC/MS)

A urine sample was collected from the patient and frozen until derivatization by the silylation of organic compounds. The GC/MS analysis was done using the Agilent system Gas chromatography instrument that is interfaced with a Mass spectrometer and Gas chromatography capillary column (Agilent, USA).

### 2.3. Molecular genetic analysis

#### 2.3.1. Next-generation sequencing

Peripheral whole blood samples were collected from the patient and parents. DNA was extracted (using Gene JET Whole Blood RNA purification Mini Kit (Thermo Scientific, Germany). The initial amount of whole genomic DNA was amplified using the Ampliseq RDY panel kit (Thermo Fisher Scientific, Waltham, MA, USA). Read trimming, alignment (hg19), and variant calling were automatically completed using the Ion Torrent Version 5.6 (ThermoFisher Scientific, Waltham, MA, USA). Variant calling files (.vcf) were uploaded to the Ion Reporter System (Thermo-Fisher Scientific, Waltham, MA, USA) for variant

annotation. Sequence alignment and extraction of SNPs were performed.

#### 2.3.2. Sanger sequencing

Sanger sequencing was performed to verify variants identified by WES and to determine the co-segregation of the candidate variant with the disease in the parents. PCR amplification was performed, and primer pairs were designed using Primer3 software (<http://primer3.ut.ee/>). Sequencing reactions of PCR products were carried out using BigDye Terminator v3.1 chemistry and separated on ABI 3500 genetic analyzer (Applied Biosystems) according to manufacturer's instructions. GenBank RefSeq [NM\\_000282.2](https://www.ncbi.nlm.nih.gov/nuccore/NM_000282.2) was used as the *PCCA* reference sequence.

### 2.4. Computational analysis

#### 2.4.1. Sequence and structural dataset

The protein sequence for the *PCCA* was obtained from the UniProt database with the ID P05165 [11]. The *PCCA* protein lacks the crystal structure in the public databases to date. Henceforth, the protein sequence obtained from the UniProt database was used to build the 3D structure of the protein using the Swiss Model online server [12]. The 3D protein model was verified using the online RAMPAGE server [13] based on an assessment of the Ramachandran Plot [14]. The RAMPAGE server approves the protein structure on the premise of  $\phi$ ,  $\psi$  point of individual deposits [13,15].

#### 2.4.2. Pathogenicity, stability, physicochemical properties analysis

The pathogenicity and the effect of the variant in destabilizing the protein structure were studied using a series of algorithms. PolyPhen-2 [16], fathmm [17], PhD-SNP [18], Pmut [19], and Pon-P2 [20], were used to predict the pathogenic effect of the novel variant p.Arg476Pro. The destabilizing properties of the p.Arg476Pro variant were studied using the mCSM [21], SDM [22], DUET [23], ENCoM [24], and DynaMut algorithms [25]. The change in physicochemical properties of the native and variant amino acids was studied using the NCBI amino acid explorer [26].

#### 2.4.3. Variant modeling and structural analysis

The novel variant p.Arg476Pro was introduced in the modeled native structure using SwissPDB viewer, and the structure was energy minimized using the same [27,28]. Visualization of the proteins and computation of the global main chain root-mean-square distance (RMSD) between the native and mutant protein was performed using Discovery Studio Visualizer software v20.1.0.19295 (Dassault Systèmes BIOVIA, San Diego, CA, USA). The change in surrounding amino acids and hydrogen bonds was also studied using the same software.

## 3. Results

### 3.1. Patients characteristics

The proband was a 2 year-old Egyptian boy, the second child of first-cousin consanguineous marriage. He was born at the 40th week of gestation, by spontaneous vaginal delivery, with a birth weight of 3.5 Kg. The family history record showed a previously deceased sibling.

The first child of the couple was a female born at full-term by spontaneous vaginal delivery, with a birth weight of 2.75 Kg. She had poor suckling and developed jaundice on day 3. She was admitted to NICU, where breast feeding was stopped, and she received phototherapy and protein-free parenteral feeding. After a few days, she was improved and discharged. At the age of 4 months, she was readmitted for lethargy, sleepiness, poor suckling, and vomiting after every feed. She was diagnosed with sepsis and died (Fig. 1).

The proband presented at the age of 3 days with jaundice and was admitted to NICU for management. Blood and urine samples were

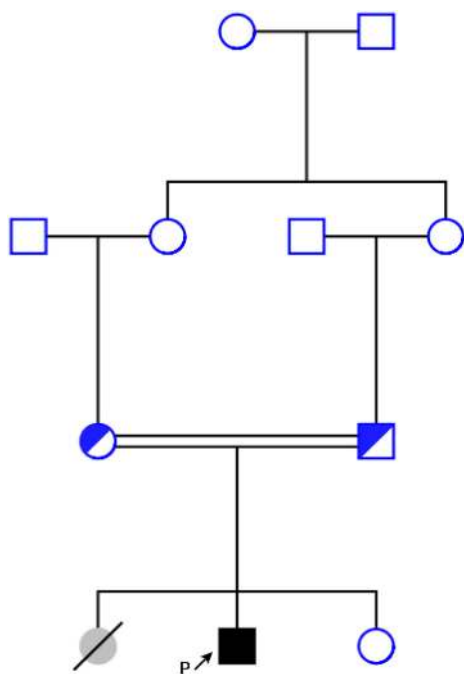

**Fig. 1.** Family Pedigree, demonstrating that the parents of the proband were heterozygous for the p.Arg476Pro variant.

**Table 1**  
Abnormal Laboratory findings at the initial presentation of the patient.

Analytes	Result	Reference Range
Total bilirubin	14.8 mg/dL	< 1 mg/dL
Direct bilirubin	2.9 mg/dL	< 0.25 mg/dL
Indirect bilirubin	11.9 mg/dL	< 0.75 mg/dL
Lactate	51.4 mg/dL	4.5–20 mg/dL
Ammonia	358 µg/dL	11–102 µg/dL
Acetylcarnitine (C2)	27.34 µmol/L	5–47 µmol/L
Propionylcarnitine (C3)	10.81 µmol/L	0–7 µmol/L
C3/C2 ratio	0.41	0.25

collected for biochemical analysis. Preliminary results showed hyperammonemia and metabolic acidosis. Given the history of the first sibling, an inborn error of metabolism was suspected. Protein intake was stopped, and the patient received glucose IV bolus followed by maintenance protein-free parenteral feeding and caloric intake of 100–120 Kcal/kg/day. He received sodium benzoate at a dose of 250 mg/Kg and L-Carnitine at a dose of 100 mg/Kg. The diagnosis of propionic acidemia was made based on the acylcarnitine profile of the blood and organic acids in urine (Table 1). Protein intake was gradually increased to reach a target total protein intake of 2 g/kg/day. Gradual improvement of biochemical parameters was noted over the next few weeks. The supplementary formula (XMTVI, Nutricia Inc, Netherlands) of protein intake was 100% deficient in methionine, threonine, valine, and isoleucine. The patient was discharged to follow up at the nearest metabolic center to his village. Long-term dietary management included keeping protein intake at 1.2–1.4 of the safe protein requirements for age, 50% of the XMTVI formula. Pharmacological therapy included sodium benzoate and sodium bicarbonate as needed to control hyperammonemia and acidosis, as well as L-Carnitine (100 mg/kg/day) and oral metronidazole (10–20 mg/kg/day for 10 days/month). The patient continued to attain age-appropriate developmental milestones without any clinical features suggestive of neurological sequelae. Over the course of treatment, the patient developed some fluctuation in the levels of ammonia and acidosis, which were managed in outpatient settings. The patient required hospitalization for one attack of metabolic encephalopathy that was precipitated by an upper respiratory

tract infection and associated with marked hyperammonemia (412 µg/dL), hypoglycemia, and acidosis. Follow-up of biochemical studies at one year of treatment showed that the level of ammonia was 81 µg/dL, C3-carnitine was 17.71 µmol/L, and C3: C2 ratio was 0.79.

### 3.2. Biochemical findings

The laboratory analysis showed a high level of total bilirubin (14.8 mg/dL), mostly unconjugated bilirubin (11.9 mg/dL). The hyperbilirubinemia was accompanied by metabolic acidosis and an elevation of ammonia (358 µg/dL) and lactate (51.4 mg/dL) (Table 1). The biochemical analysis of the amino acid-acylcarnitine was performed on a dried blood spot (DBS) using LC-MS/MS technique, and findings were consistent with either propionic or methylmalonic acidemia. The MS/MS measurement revealed highly elevated propionyl carnitine (C3, 27.34 µmol/L) with a very highly elevated C3/C2 ratio (0.41) (Table 1).

Urine examination for organic acid using GC/MS showed a moderately elevated hydroxy propionic and significantly elevated methyl citrate that were suggestive of PA. The huge amount of hippuric acids was masking some other analytes.

### 3.3. Molecular genetic findings

Whole exome sequence analysis showed the patient to be homozygous for a novel missense variant affecting the locus (chr13:100962160) of exon 16 of the *PCCA* gene. The c.1427G > C variant leads to the substitution of the amino acid Arginine with Proline at site 476 of the amino acid sequence of the protein chain (p.Arg476Pro). No other pathological or likely pathological variants were detected in the *PCCA* and *PCCB* loci. This variant was absent in 300 normal chromosomes. Sanger DNA sequencing confirmed the heterozygous status of both parents for the same variant.

### 3.4. Computational analysis

#### 3.4.1. Protein modeling and validation

The 3D structure of the PCCA protein was modeled using the online Swiss Model web-based client. The crystal structure of the holoenzyme of propionyl-CoA carboxylase (PCC) of the *Ruegeria pomeroyi* species with PDB ID 3N6R was found to be the most suitable template to build the protein model with a sequence identity of 53.94%. This modeled protein structure was further subjected to the validation for Ramachandran plot calculations. This validation was done using the online RAMPAGE server. From the validation plot, we observed that the number of residues in the favored region was 89.0%, the number of residues in the allowed region was 8.4%, and the number of residues in the outlier region was 2.6% (Fig. 2).

#### 3.4.2. Pathogenicity, stability, physicochemical properties analysis

Pathogenicity and stability of the novel variant p.Arg476Pro were predicted using five algorithms for each. The pathogenicity predictors, PolyPhen-2, FATHMM, PhD-SNP, Pmut, and Pon-P2, predicted the new variant p.Arg476Pro to be probably damaging, damaging, disease, disease, and pathogenic, respectively (Table 2). The stability predictors, mCSM, SDM, DUET, ENCoM, and DynaMut predicted the new variant p.Arg476Pro to be destabilizing (Table 2). The difference in the physicochemical properties of the native arginine and variant proline was studied using the NCBI amino acid explorer (Table 3). From the study, it was identified that the side-chain flexibility, which was high in the native arginine, was restricted due to the variant proline. Similarly, due to the variant proline, the Ionic and H-bonds were lost, which were initially present in the native arginine. Significantly, the loss of 7 potential side-chain H-bonds due to the variant proline was also observed (Table 4).

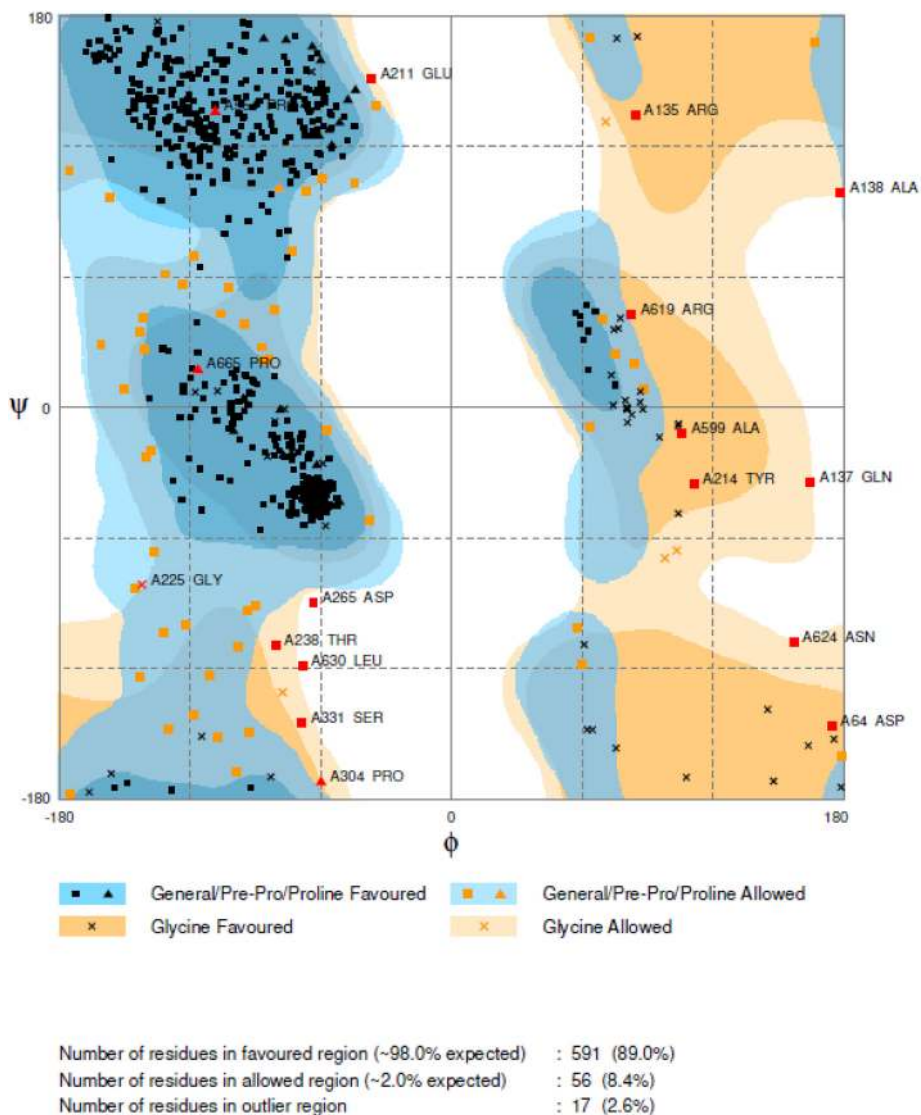

Fig. 2. Ramachandran plot validation of the modeled PCCA 3D protein structure. The plot reveals that the number of residues in the favored region was 89.0%, the number of residues in the allowed region was 8.4%, and the number of residues in the outlier region was 2.6%.

**Table 2**  
Pathogenicity prediction of the novel variant p.Arg476Pro of PCCA protein.

S.No	Algorithm	Prediction	Score
1	PolyPhen-2	Probably damaging	1
2	fathmm	Damaging	-1.55
3	PhD-SNP	Disease	1
4	Pmut	Disease	0.71
5	Pon-P2	Pathogenic	0.9

**Table 3**  
Stability changes prediction of the novel variant p.Arg476Pro of PCCA protein.

S.No	Algorithm	Prediction	ΔΔG (kcal/mol)
1	mCSM	Destabilizing	-0.109
2	SDM	Destabilizing	-1.64
3	DUET	Destabilizing	-0.489
4	ENCoM	Destabilizing	-0.595
5	DynaMut	Destabilizing	-0.01

**Table 4**  
The difference in the physicochemical properties of native arginine and variant proline of the novel variant p.Arg476Pro of PCCA protein.

Feature	Arginine	Proline
Side-chain flexibility	High	Restricted
Interaction modes	Ionic, H-bonds, van der Waals	van der Waals
Potential side-chain H-bonds	7	0
Residue molecular weight	156	97
Isoelectric point	10.8	6.3
Hydrophobicity	0	0.678
Standard codon(s)	CGN, AGR	CCN
Charge	Positive	Nonpolar

3.4.3. Structural analysis

The structural analysis of the native and PCCA with variant p.Arg476Pro proteins was studied using Discovery Studio Visualizer software v20.1.0.19295 (Dassault Systèmes BIOVIA, San Diego, CA, USA). The RMSD between the native and variant PCCA was found to be 0.038 Å. The loss of beta-sheet due to the variant proline was also observed (Fig. 3). In addition, we observed the loss of interacting amino

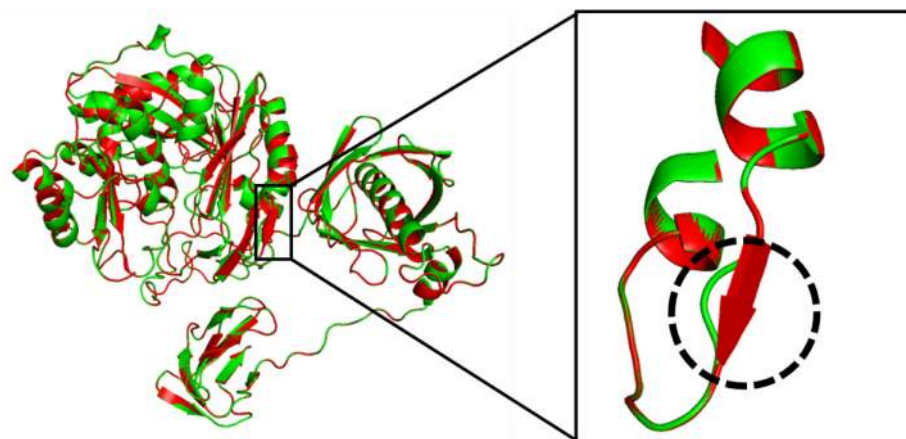

**Fig. 3.** Computational modeling to predict the impact of novel variant on PCCA protein. The PCCA protein with novel variant p.Arg476Pro (Green) superimposed with the native PCCA (Red) visualized by the Discovery Studio visualizer software. The enlarged image shows the loss of the beta-sheet due to the variant p.Arg476Pro.

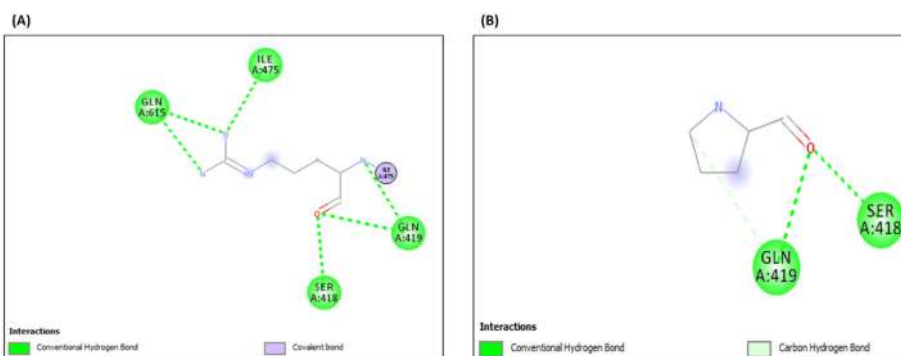

**Fig. 4.** Change in the interacting amino acids between the native arginine and variant proline at the 476th position of PCCA protein. (A) PCCA with native arginine (B) PCCA with variant proline.

acids and hydrogen bonds due to the novel variant p.Arg476Pro. The native arginine at position 476 showed four amino acids interactions (SER418, GLN419, ILE475, and GLN615) with six conventional hydrogen bonds (2 with GLN415, 2 with GLN615, 1 with ILE475, and 1 with SER418) and one covalent bond (ILE475) (Fig. 4A). While the variant proline at position 476 showed only two amino acid interactions (SER418 and GLN419) with one conventional hydrogen bonds, respectively (Fig. 4B).

#### 4. Discussion

In this study, we report the identification of a novel homozygous variant *PCCA*: c.1427G > C (p.Arg476Pro), affecting the locus (chr13:100962160) of exon 16 of *PCCA* gene, in an Egyptian patient diagnosed with propionic acidemia; the diagnosis was initially made according to the clinical evaluation, acylcarnitine, and organic acid profiles and confirmed by next-generation sequencing of the patient and Sanger sequencing of his parents who were found to be heterozygous for the same variant. To the best of our knowledge, this variant has not been reported in different databases (1000 Genomes, dbSNP, ESP, ExAC, HGMD, and gnomAD), and was absent in 300 normal chromosomes.

History of consanguinity and the neonatal death of the sister of the proband led us to do a careful genetic investigation, especially with the classical presentation of propionic acidemia for his deceased sister. Although she was diagnosed with neonatal sepsis, the diagnosis of propionic acidemia should also be considered based on her clinical presentation and her transient improvement upon discontinuation of oral feeding during hospitalization. Advancement of high-throughput sequencing, particularly WES, has facilitated identifying variations or even novel genes associated with human diseases and complex traits. In this study, used WES to identify this novel variant *PCCA*: c.1427G > C,

which was found in the proband with a WES sequencing coverage depth of  $100\times$ , which was convincing to call the variant. No variants were found in the *PCCB* gene. The heterozygous status was confirmed in both parents using Sanger sequencing.

In the absence of newborn screening, the diagnosis of several inborn errors of metabolism at primary care units is likely to be missed or delayed; indicating the importance of the availability of a nationwide extended screening program to prevent the common morbidities and mortalities of patients with an inborn error of metabolism especially in developing countries [7]. The clinical application of our study is the confirmation of the genetic diagnosis in patients, enabling accurate genetic counseling and, in many cases, providing a prognostic view of the probable course of the disease. However, the genetic heterogeneity present in PA patients, with most variants being “private,” present in only one family, along with the practical absence of homozygosity among the studied patients, hinders a straightforward genotype-phenotype correlation [7,29], and, in other cases, modulation of the effect of particular variants by genetic and epigenetic factors contribute to phenotypic variability.

The associated metabolic acidosis resulting from the accumulation of branched-chain amino acid, their intermediates, and all upstream metabolites of propionyl-CoA and hyperlactatemia is related to the potential indirect influence of propionyl-CoA to decrease the activity of pyruvate dehydrogenase and increase lactate [6]. In the presence of hyperammonemia, determination of blood amino acids, acylcarnitine, and the urinary organic acid using LC-MS/MS and GC/MS techniques were essential to lead for accurate differential diagnosis toward PA.

The *PCCA* with p.Arg476Pro variant was found to be pathogenic by all the algorithms utilized in this study (Table 2). According to the standards and guidelines for the interpretation of sequence variants and the joint consensus of the American College of Medical Genetics and the Association of Molecular genetics, this variant is “likely pathogenic (V)”

[43]. It fulfills 2 moderate and 3 supporting criteria, namely PM1, PM2, PP2, PP3, and PP4.

The stability predictors suggest that the variant-induced in protein might lead to destabilization of the PCCA protein structure (Table 3). This is a common mechanism in many metabolic diseases [30,31]. They are also known to play a crucial role in maintaining the stability of the protein [32–36]. Proline amino acid is well studied as a potent secondary structure breaker of alpha-helices as well as the beta sheets [37]. In the structural study, we observed a transformation of beta-sheet to loop, thus serving a main reason for the loss of stability, which correlates with our stability predictors' results (Fig. 2 and Table 3). Furthermore, amino acid interactions and hydrogen bonds are known to play a crucial role in maintaining the stability of the proteins [38,39]. In our study, the loss of hydrogen bonds and the interacting amino acids revealed by the structural analysis further elucidate that the protein could have severe stability loss due to the novel variant p.Arg476Pro. This stability loss and protein structural changes make this novel variant more significant in causing PA. These findings agree with previous studies indicating that the loss of function of most PCCA variant proteins is based on protein reduction due to decreased stability [40,41].

The distinctive architecture among Arabs and the common consanguineous marriage practices is expected to create a unique susceptibility profile for rare genetic diseases, including PA [42]. Our findings add to the growing list of reported variants in PCCA in PA patients. Moreover, the present report underscores the usefulness of WES in combination with extensive in silico studies as powerful tools for rapid diagnosis and classification of PA-causing variants.

## Funding

This research did not receive any specific grant from funding agencies in the public, commercial, or not-for-profit sectors.

## Declaration of Competing Interest

All author declare that they have no conflict of interest.

## Acknowledgements

Open Access funding provided by the Qatar National Library. The findings and conclusions in this report are solely the responsibility of the authors. The authors would like to thank the management of Faculty of Medicine, Ain Shams University, Cairo, Egypt; Vellore Institute of Technology, India; and Qatar University, Qatar, for providing the necessary research facilities to carry out this work.

## References

- [1] P. Wongkittichote, N. Ah Mew, K.A. Chapman, Propionyl-CoA carboxylase - a review, *Mol. Genet. Metab.* 122 (4) (2017) 145–152, <https://doi.org/10.1016/j.ymgme.2017.10.002>.
- [2] M.P. Adam, H.H. Ardinger, R.A. Pagon, S.E. Wallace, L.J.H. Bean, K. Stephens, A. Amemiya (Eds.), *GeneReviews*® [Internet], University of Washington, Seattle, WA, 1993–2020 Available from: <https://www.ncbi.nlm.nih.gov/books/NBK1116/>.
- [3] T. Ohura, [Propionic acidemia]. *Ryoikibetsu Shokogun Shirizu*, 18 Pt 1 (1998), pp. 276–279 Retrieved from <https://www.ncbi.nlm.nih.gov/pubmed/9590046>.
- [4] M.R. Baumgartner, F. Hörster, C. Dionisi-Vici, G. Haliloglu, D. Karall, K.A. Chapman, ... A. Chakrapani, Proposed guidelines for the diagnosis and management of methylmalonic and propionic acidemia, *Orphanet J. Rare Dis.* 9 (2014) 130, <https://doi.org/10.1186/s13023-014-0130-8>.
- [5] P. Stenson, M. Mort, E. Ball, K. Evans, M. Hayden, S. Heywood, M. Hussain, A. Phillips, D. Cooper, *The Human Gene Mutation Database: towards a comprehensive repository of inherited mutation data for medical research, genetic diagnosis and next-generation sequencing studies*, *Hum. Genet.* 136 (6) (2017) 665–677.
- [6] H.A. Haijes, J.J.M. Jans, M. van der Ham, P.M. van Hasselt, N.M. Verhoeven-Duif, Understanding acute metabolic decompensation in propionic and methylmalonic acidemias: a deep metabolic phenotyping approach, *Orphanet J. Rare Dis.* 15 (1) (2020) 68, <https://doi.org/10.1186/s13023-020-1347-3>.
- [7] H. Zayed, Propionic acidemia in the Arab world, *Gene* 564 (2) (2015) 119–124, <https://doi.org/10.1016/j.gene.2015.04.019>.
- [8] S.N. Kim, K.H. Ryu, E.H. Lee, J.S. Kim, S.H. Hahn, Molecular analysis of PCCB gene in Korean patients with propionic acidemia, *Mol. Genet. Metab.* 77 (3) (2002) 209–216, [https://doi.org/10.1016/S1096-7192\(02\)00139-7](https://doi.org/10.1016/S1096-7192(02)00139-7).
- [9] T. Ohura, K. Narisawa, K. Tada, Propionic acidemia: sequence analysis of mutant mRNAs from Japanese beta subunit-deficient patients, *J. Inher. Metab. Dis.* 16 (5) (1993) 863–867, <https://doi.org/10.1007/bf00714279>.
- [10] T. Tahara, J.P. Kraus, T. Ohura, L.E. Rosenberg, W.A. Fenton, Three independent mutations in the same exon of the PCCB gene: differences between Caucasian and Japanese propionic acidemia, *J. Inher. Metab. Dis.* 16 (2) (1993) 353–360, <https://doi.org/10.1007/BF00710282>.
- [11] R. Apweiler, A. Bairoch, C.H. Wu, W.C. Barker, B. Boeckmann, S. Ferro, ... L.S. Yeh, UniProt: the universal protein knowledgebase, *Nucleic Acids Res.* 32 (Database issue) (2004) D115–D119, <https://doi.org/10.1093/nar/gkh131>.
- [12] M. Biasini, S. Bienert, A. Waterhouse, K. Arnold, G. Studer, T. Schmidt, ... T. Schwede, SWISS-MODEL: modelling protein tertiary and quaternary structure using evolutionary information, *Nucleic Acids Res.* 42 (Web Server issue) (2014) W252–W258, <https://doi.org/10.1093/nar/gku340>.
- [13] S.C. Lovell, I.W. Davis, W.B. Arendall 3rd, P.I. de Bakker, J.M. Word, M.G. Prisant, ... D.C. Richardson, Structure validation by Ramachandran geometry: phi, psi and Cbeta deviation, *Proteins* 50 (3) (2003) 437–450, <https://doi.org/10.1002/prot.10286>.
- [14] G.N. Ramachandran, C. Ramakrishnan, V. Sasisekharan, Stereochemistry of polypeptide chain configurations, *J. Mol. Biol.* 7 (1963) 95–99, [https://doi.org/10.1016/s0022-2836\(63\)80023-6](https://doi.org/10.1016/s0022-2836(63)80023-6).
- [15] T.C. Dakal, R. Kumar, D. Ramotar, Structural modeling of human organic cation transporters, *Comput. Biol. Chem.* 68 (2017) 153–163, <https://doi.org/10.1016/j.cmbiolchem.2017.03.007>.
- [16] I. Adzhubei, D.M. Jordan, S.R. Sunyaev, Predicting functional effect of human missense mutations using PolyPhen-2, *Curr. Protoc. Hum. Genet.* 20 (2013), <https://doi.org/10.1002/0471142905.hg0720s76> Chapter 7, Unit 7.
- [17] H.A. Shihab, J. Gough, D.N. Cooper, P.D. Stenson, G.L. Barker, K.J. Edwards, ... T.R. Gaunt, Predicting the functional, molecular, and phenotypic consequences of amino acid substitutions using hidden Markov models, *Hum. Mutat.* 34 (1) (2013) 57–65, <https://doi.org/10.1002/humu.22225>.
- [18] E. Capriotti, R. Calabrese, R. Casadio, Predicting the insurgence of human genetic diseases associated to single point protein mutations with support vector machines and evolutionary information, *Bioinformatics* 22 (22) (2006) 2729–2734, <https://doi.org/10.1093/bioinformatics/btl423>.
- [19] V. López-Ferrando, A. Gazzo, X. de la Cruz, M. Orozco, J.L. Gelpi, PMut: a web-based tool for the annotation of pathological variants on proteins, 2017 update, *Nucleic Acids Res.* 45 (W1) (2017) W222–W228, <https://doi.org/10.1093/nar/gkx313>.
- [20] A. Nirooula, S. Urolagin, M. Vihinen, PON-P2: prediction method for fast and reliable identification of harmful variants, *PLoS One* 10 (2) (2015) e0117380, <https://doi.org/10.1371/journal.pone.0117380>.
- [21] D.E. Pires, D.B. Ascher, T.L. Blundell, mCSM: predicting the effects of mutations in proteins using graph-based signatures, *Bioinformatics* 30 (3) (2014) 335–342, <https://doi.org/10.1093/bioinformatics/btt691>.
- [22] A.P. Pandurangan, B. Ochoa-Montaño, D.B. Ascher, T.L. Blundell, SDM: a server for predicting effects of mutations on protein stability, *Nucleic Acids Res.* 45 (W1) (2017) W229–W235, <https://doi.org/10.1093/nar/gkx439>.
- [23] D.E. Pires, D.B. Ascher, T.L. Blundell, DUET: a server for predicting effects of mutations on protein stability using an integrated computational approach, *Nucleic Acids Res.* 42 (Web Server issue) (2014) W314–W319, <https://doi.org/10.1093/nar/gku411>.
- [24] V. Frappier, M. Chartier, R.J. Najmanovich, ENCoM server: exploring protein conformational space and the effect of mutations on protein function and stability, *Nucleic Acids Res.* 43 (W1) (2015) W395–W400, <https://doi.org/10.1093/nar/gkv343>.
- [25] C.H. Rodrigues, D.E. Pires, D.B. Ascher, DynaMut: predicting the impact of mutations on protein conformation, flexibility and stability, *Nucleic Acids Res.* 46 (W1) (2018) W350–W355, <https://doi.org/10.1093/nar/gky300>.
- [26] B. Bulka, M. desJardins, S.J. Freeland, An interactive visualization tool to explore the biophysical properties of amino acids and their contribution to substitution matrices, *BMC Bioinforma.* 7 (2006) 329, <https://doi.org/10.1186/1471-2105-7-329>.
- [27] N. Guex, M.C. Peitsch, SWISS-MODEL and the Swiss-PdbViewer: an environment for comparative protein modeling, *Electrophoresis* 18 (15) (1997) 2714–2723, <https://doi.org/10.1002/elps.1150181505>.
- [28] W.F. van Gunsteren, S.R. Billeter, A.A. Eising, P.H. Hünenberger, P. Krüger, A.E. Mark, ... I.G. Tironi, *Biomolecular Simulation: The GROMOS96 Manual and User Guide*, Vdf Hochschulverlag AG an der ETH Zürich, Zürich, Switzerland, 1996.
- [29] L.R. Desviat, B. Pérez, C. Pérez-Cerdá, P. Rodríguez-Pombo, S. Clavero, M. Ugarte, Propionic acidemia: mutation update and functional and structural effects of the variant alleles, *Mol. Genet. Metab.* 83 (1–2) (2004) 28–37, <https://doi.org/10.1016/j.ymgme.2004.08.001>.
- [30] P. Forny, D.S. Froese, T. Suormala, W.W. Yue, M.R. Baumgartner, Functional characterization and categorization of missense mutations that cause methylmalonyl-CoA mutase (MUT) deficiency, *Hum. Mutat.* 35 (12) (2014) 1449–1458, <https://doi.org/10.1002/humu.22633>.
- [31] A.L. Pey, F. Stricher, L. Serrano, A. Martinez, Predicted effects of missense mutations on native-state stability account for phenotypic outcome in phenylketonuria, a paradigm of misfolding diseases, *Am. J. Hum. Genet.* 81 (5) (2007) 1006–1024, <https://doi.org/10.1086/521879>.

- [32] A.K. Agrahari, A. Kumar, H. Zayed, Substitution impact of highly conserved arginine residue at position 75 in GJB1 gene in association with X-linked Charcot-Marie-tooth disease: a computational study, *J. Theor. Biol.* 437 (2018) 305–317, <https://doi.org/10.1016/j.jtbi.2017.10.028>.
- [33] A.K. Agrahari, M. Muskan, C. George Priya Doss, R. Siva, H. Zayed, Computational insights of K1444N substitution in GAP-related domain of NF1 gene associated with neurofibromatosis type 1 disease: a molecular modeling and dynamics approach, *Metab. Brain Dis.* 33 (5) (2018) 1443–1457, <https://doi.org/10.1007/s11011-018-0251-1>.
- [34] D. Thirumal Kumar, L. Jerushah Emerald, C. George Priya Doss, P. Sneha, R. Siva, W. Charles Emmanuel Jebaraj, H. Zayed, Computational approach to unravel the impact of missense mutations of proteins (D2HGDH and IDH2) causing D-2-hydroxyglutaric aciduria 2, *Metab. Brain Dis.* 33 (5) (2018) 1699–1710, <https://doi.org/10.1007/s11011-018-0278-3>.
- [35] O.K. Zaki, N. Krishnamoorthy, H.S. El Abd, S.A. Harche, R.A. Mattar, R.S. Al Disi, ... H. Zayed, Two patients with Canavan disease and structural modeling of a novel mutation, *Metab. Brain Dis.* 32 (1) (2017) 171–177, <https://doi.org/10.1007/s11011-016-9896-9>.
- [36] O.K. Zaki, C.G. Priya Doss, S.A. Ali, G.G. Murad, S.A. Elashi, M.S.A. Ebnou, ... H. Zayed, Genotype-phenotype correlation in patients with isovaleric acidemia: comparative structural modelling and computational analysis of novel variants, *Hum. Mol. Genet.* 26 (16) (2017) 3105–3115, <https://doi.org/10.1093/hmg/ddx195>.
- [37] S.C. Li, N.K. Goto, K.A. Williams, C.M. Deber, Alpha-helical, but not beta-sheet, propensity of proline is determined by peptide environment, *Proc. Natl. Acad. Sci. U. S. A.* 93 (13) (1996) 6676–6681, <https://doi.org/10.1073/pnas.93.13.6676>.
- [38] A.E. Garcia, K.Y. Sanbonmatsu, Alpha-helical stabilization by side chain shielding of backbone hydrogen bonds, *Proc. Natl. Acad. Sci. U. S. A.* 99 (5) (2002) 2782–2787, <https://doi.org/10.1073/pnas.042496899>.
- [39] C.N. Pace, H. Fu, K.L. Fryar, J. Landua, S.R. Trevino, B.A. Shirley, ... G.R. Grimsley, Contribution of hydrophobic interactions to protein stability, *J. Mol. Biol.* 408 (3) (2011) 514–528, <https://doi.org/10.1016/j.jmb.2011.02.053>.
- [40] M. Chloupkova, K.N. Maclean, A. Alkhateeb, J.P. Kraus, Propionic acidemia: analysis of mutant propionyl-CoA carboxylase enzymes expressed in *Escherichia coli*, *Hum. Mutat.* 19 (6) (2002) 629–640, <https://doi.org/10.1002/humu.10085>.
- [41] H. Jiang, K.S. Rao, V.C. Yee, J.P. Kraus, Characterization of four variant forms of human propionyl-CoA carboxylase expressed in *Escherichia coli*, *J. Biol. Chem.* 280 (30) (2005) 27719–27727, <https://doi.org/10.1074/jbc.M413281200>.
- [42] H. Zayed, The Arab genome: health and wealth, *Gene* 592 (2) (2016) 239–243, <https://doi.org/10.1016/j.gene.2016.07.007>.
- [43] S. Richards, N. Aziz, S. Bale, D. Bick, S. Das, J. Gastier-Foster, W. Grody, M. Hegde, E. Lyon, E. Spector, K. Voelkerding, H. Rehm, Standards and guidelines for the interpretation of sequence variants: a joint consensus recommendation of the American College of Medical Genetics and Genomics and the Association for Molecular Pathology, *Genet. Med.* 17 (5) (2015) 405–423.