

Date of publication xxxx 00, 0000, date of current version xxxx 00, 0000.

Digital Object Identifier 10.1109/ACCESS.2020.Doi Number

# Modeling and Assessment of Lightning Hazards to Humans in Heritage Monuments in India and Sri Lanka

S. Venkatesh<sup>1</sup>, Member, IEEE, Manjula Fernando<sup>2</sup>, Senior Member, IEEE, Sarath Kumara<sup>2</sup>, Senior Member IEEE, S. Thirumalini<sup>3</sup>, Vernon Cooray<sup>4</sup>, Fellow, IEEE

<sup>1</sup>School of Electrical Engineering, Vellore Institute of Technology, Vellore, 632014 India

<sup>2</sup>Department of Electrical and Electronic Engineering, University of Peradeniya, 20400 Sri Lanka

<sup>3</sup>School of Civil Engineering, Vellore Institute of Technology, Vellore, 632014 India

<sup>4</sup>Department of Electrical Engineering, Division for Electricity and Lightning Research, Uppsala University, 752 36 Uppsala Sweden

Corresponding author: S. Venkatesh (e-mail: venkatesh.srinivasan@vit.ac.in)

This work is a part of the Bilateral India-Sri Lanka Research Project awarded by Department of Science & Technology (DST), Government of India and Ministry of Science, Research and Technology (MSRT), Sri Lanka.

**ABSTRACT** Lightning is one of the inevitable disastrous phenomena which in addition to damaging tall edifices, might also consequently endanger humans due to lightning-human interactions. This research focuses on analyzing lightning hazards to humans in the vicinity of heritage monuments in India and Sri Lanka. Five monuments which include three giant stupas namely Ruwanweliseya, Jethawanaramaya and Abayagiriyaya from Sri Lanka and two large temples namely Brihadishvara Temple and Gangaikonda Cholapuram from India have been chosen for investigation. Lightning-human interaction mechanisms namely direct strike, side flash, aborted upward leader, step and touch voltages have been investigated for the most onerous scenario on humans in the vicinity of the monuments. Firstly, the electro-geometric model as stipulated in standards has been implemented to ascertain the effectiveness of lightning protection to the structures. Subsequently, the study has been extended to the computation of step and touch voltages utilizing lightning current and electrostatic models based on Finite Element Method (FEM) using COMSOL Multi-physics<sup>®</sup>. Detailed plots of electric field and voltage distribution of lightning on humans due to a typical lightning current of 30 kA have been obtained. The final study involves assessment of current through humans which is estimated based on lumped R-C human model representation using OrCAD Cadence<sup>®</sup>. The analyses reveal that humans are invariably shielded against direct strikes whereas effects due to side flashes are minimal. During strikes to the monuments, high voltage may appear due to step and touch potential under dry conditions, though such effects could be mitigated by appropriate earthing system.

**INDEX TERMS** Lightning Protection System (LPS), Electro-geometric Model (EGM), Finite Element Method (FEM), Rolling Sphere Method (RSM), Lightning Protection Zone (LPZ)

## I. INTRODUCTION

Lightning is a natural and inevitable phenomenon accompanied by significant transient current of high magnitudes which may consequently have severe deleterious effects on human, livestock whereby leading to fatal injuries, in addition to causing significant damages on tall human-made edifices and heritage monuments of importance. Among the two main types of lightning flashes, namely cloud-to-cloud (CC) and cloud-to-ground (CG), the

CG lightning is the most severe hazard as far as human safety is concerned [1]. Such lightning strikes are formed by a group of cumulus clouds, which in turn propagate to the ground as a stepped leader and finally neutralize with the oppositely charged ground objects. Research studies indicate that almost two thirds of thunderstorms occurring in the globe are invariably in the tropical regions. From both the Indian and the Sri Lankan context though the geographical topology and weather undergo wide seasonal

variations, a majority of the vast geography can be categorized as a part of tropical climate. Furthermore, recent studies indicate plausible connection between climate changes due to global warming and the need to have a clear understanding of the interactions between the frequency of occurrence and distribution of lightning discharges etc. It is also pertinent to note that studies based on recent research clearly indicate that the total number of fatal accidents to mankind caused by lightning around the world ranges from 6,000 to 24,000 per year [2, 3]. Considering recent lightning incidents, it is reported that annual deaths due to lightning strikes per million people in India and Sri Lanka are of the order of 2.5 during 21<sup>st</sup> century and it is comparatively higher than several other countries which have a non-tropical climate [4]. A study conducted on incidence of fatalities in India from 1979 to 2011 also indicated that a majority of incidents are reported in west and central part of India [4, 5]. Similarly, a study conducted on lightning incidents in 2003 in Sri Lanka reveals that the rate of lightning incidence is similar throughout the country and a majority of casualties has occurred due to step voltage and side flashes mainly due to ignorance, staying outdoors and in partially covered shelters near buildings during lightning [6].

Incidentally, it is also worth mentioning that during the past decade, there has been a surge in the number of damages related to lightning strikes on heritage monuments. Preservation of cultural heritage monuments which are invariably tall (structures had been built in ancient times by emperors either to commemorate their victories or constructed as places for religious congregation and worship) has become a challenging task since they are vulnerable to pollution, environmental hazards (chemical effluents from industries), fatigue of structural materials etc. In this context, it is also essential to recognize that detailed studies carried out in [7, 8] summarize a few of the major lightning strikes that have been reported to have caused substantial damages and deformation of the heritage structures, more so on world heritage monuments of importance. On the other hand, in a similar vein, it becomes pertinent to ascertain the human fatalities associated with lightning strikes both globally as well as from the context of Indian and Sri Lankan perspective, since it is obvious that both countries share a rich tradition of a large number of heritage sites of worship related to various religious faiths. Hence, it becomes extremely appropriate and essential to assess the risk index related to the heritage structure as well as hazard to humans (tourists, devotees, pilgrims etc) in line with the requirements of IEC 62305 [9]. Notwithstanding, it is also important that from the context of Indian and Sri Lankan heritage monuments, places of worship and important structures that signify historical relevance from the 1<sup>st</sup> century AD have been receiving wide attention and attraction from tourists and pilgrims worldwide. It is evident that such tall monuments

could have the possibility of both cloud and ground (CG) initiated lightning flashes. The probability of such lightning strikes may furthermore be enhanced due to the likelihood of severe monsoon (both south-western and north-eastern) since the southern peninsular region of India and Sri Lanka experience intensive lightning activity.

Hence, it is obvious that both in Sri Lanka and India lightning protection system (LPS), which is in compliance with the relevant standards of the country as well as in line with the requirements stipulated in IEC 62305 [9] and NFPA 780 [10] has been installed. However, several challenges related to the effectiveness of such LPS installations namely efficacy of the lightning zone of protection (LPZ) in the context of large heritage structures, limitations and complexities based on the existing LPS scheme related to very tall structures [11,12], complications in ensuring effective implementation of risk assessment in heritage due to human hazards due to lightning etc present considerable challenges to researchers.

This research hence focuses on carrying out detailed studies and analysis based on the LPS that has been already installed in the monuments that are being managed by the archeological conservation and preservation fraternity (Archaeological Survey of India and Sri Lanka). The existing LPS invites the prospective lightning leader which in turn passes through the down conductors to the ground, whereby necessitating a thorough analysis on the human-lightning interaction due to the likelihood of devotees staying in the vicinity and premises of the heritage structure. In this regard, with the objectives of identifying human safety hazards and mitigation methods, five human-lightning interaction mechanisms have been taken up for analysis based on specifically identified monuments which are reported to have had instances of lightning strikes in recent times. In the initial phase of the study, the protective angle method (PAM) and rolling sphere method (RSM) as stipulated in IEC 62305 and NFPA780 have been implemented by considering the geometrical and electro-geometrical aspects of the test cases to identify the lightning protection zone (LPZ) and the regions of shielding effectiveness in locations where the devotees stay during worship. In the second phase of the research, finite element based approach has been utilized to ascertain the indirect effect of lightning on devotees by considering the grounding efficiency in addition to the efficacy of LPZ based electro-geometrical models. In order to assess the effect of lightning strikes on human obtained from the finite element studies, a lumped human model representation [13] related to the various case studies has been implemented to ascertain the impact of human-lightning interaction.

## II. AN OVERVIEW OF LIGHTNING STRIKES ON HERITAGE MONUMENTS IN INDIA AND SRI LANKA

It is evident from the foregoing discussion that intense monsoon associated with the tropical climate, inherently tall

historical structures and edifices of significance, prolonged environmental fatigue associated with ancient structures etc have significant role in lightning strikes of structures in both the countries. From the Indian context, considerable analysis of lightning strikes and its associated damages to heritage monuments have been carried out by researchers and scientists of Archeological Survey of India (ASI). The reports of such studies [14-22] relate to a variety of temples, churches and mosques of importance, including those of the world heritage monuments under the aegis of United Nations Educational, Scientific and Cultural Organization (UNESCO). Similarly from the Sri Lankan viewpoint, to the best of the knowledge of the authors of this research, such documented reports on lightning incidences are not in vogue. However, a few articles and news reports have indicated instances of lightning in Mihinthale stupa in 2010 [23] and strikes on metallic shelter enclosing the Avukana Buddha statue [24]. Further, recent studies of lightning strikes based on LPS and the associated surge counters installed in Jethawanaramaya and Abayagiriya stupas have also indicated some significant lightning incidents. The details of the various monuments and instances of lightning strikes including damages sustained by the structures are indicated in Fig.1, Fig. 2, Fig. 3, Fig. 4, Fig. 5, Fig.6, Fig. 7 and Table I.



**FIGURE 1.** Brihadishvara Temple – Lightning Strike shattered the spire atop Rajarajon Tower (Gopuram) in 2010



**FIGURE 2.** Brihadishvara Temple – Lightning strike chipped-off mortar in precincts adjacent to main tower (Sri Vimana) in 2011



**FIGURE 3.** Brihadishvara Temple – Lightning strike damaged a sculpture in the top portion of the entrance tower (Keralanthagan gopuram) in 2018



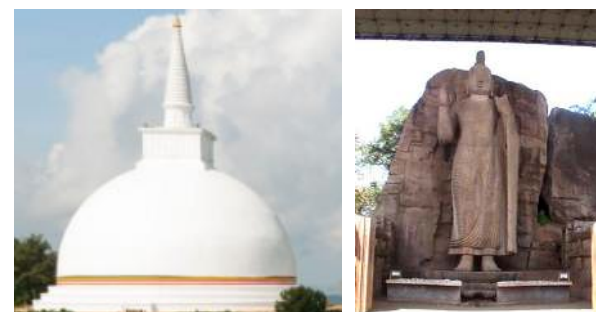
**FIGURE 4.** Lightning Damages (a) Rathneswar Mahadeshwar Temple and (b) Jagadambika Temple in 2016 and 2015 respectively



**FIGURE 5.** Lightning Strikes in (a) Jameswar and (b) Nilamdhhab Temples respectively



**FIGURE 6.** Damaged roof and gables due to lightning strikes in Se Cathedral and Basilica of Bom Churches at Goa during 2015 and 2016 respectively



**FIGURE 7.** Lightning strikes in Mihinthale stupa and Avukana Lord Buddha Statue respectively in Sri Lanka during 2010 and 2017 respectively



TABLE I  
REPORTED LIGHTNING STRIKES TO TEMPLES, CHURCHES AND MOSQUES IN INDIA AND STUPAS AND STATUES IN SRI LANKA

| Heritage monument   | Location and year  | Nature of Lightning Damage   |
|---|--|--|
| <b>Brihadishvara Temple- Rajarajan Tower (Gopuram)</b>            | Thanjavur, India, 2010                                       | <ol style="list-style-type: none"> <li>1. One of the five spires (called 'kalash') on 'Rajarajan Thiruvayil (gopuram)', which is the middle gopuram from the entrance of the Big Temple, had been damaged following a lightning strike during the heavy rain to the structures</li> <li>2. In 2014, it was observed that cracks had developed in the beams leading to seepage of rain water with possibility to consequent structural instability</li> </ol> |
| <b>Brihadishvara Temple- Precincts of Main Tower (Sri Vimana)</b> | Thanjavur, India, 2011                                       | <ol style="list-style-type: none"> <li>1. Lightning struck the adjoining precinct structure (called 'Mandapam') of the main tower (called 'Vimana'). No incidence of lightning striking the main Vimana. But, lightning struck the precincts of adjoin structure of the tower, leading to cracks on its surface</li> <li>2. The roof of the adjoining mandapam had developed cracks.</li> </ol>  |
| <b>Brihadishvara Temple- Keralanthagan Gopuram</b>                | Thanjavur, India, 2018                                       | <ol style="list-style-type: none"> <li>1. A portion on the top right side of the gopuram was shattered and some pieces were felled.</li> <li>2. A portion of the structure known as 'Keerthimugam' (ornate sculpture) has been shattered and was damaged</li> </ol>  |
| <b>Ratneshwar Mahadev Temple (Leaning Temple of Kashi)</b>        | Varansi, India, 2016   | <ol style="list-style-type: none"> <li>1. Damaged due to heavy lightning led to shattering of the spire which weighed nearly 50 kg, atop the temple tower</li> <li>2. However, there were no reports of injuries to human during the incident.</li> </ol>  |
| <b>Devi Jagadambika Temple - Khajuraho</b>                        | Madhya Pradesh, India, 2015                                  | <ol style="list-style-type: none"> <li>1. Lightning hit the top part of temple inside the Western group of temples damaging it.</li> <li>2. The top part of the temple's Kalash (called 'Beejpurak') weighing around 6 kg had fallen.</li> <li>3. Lightning also hit a 17-year-old girl, which was reported to be fatal.</li> </ol>  |
| <b>Jameswar Temple Nilandhab Temple</b>                           | Bhubaneswar, India, 2016<br>Khandapada – Odisha, India, 2016 | <ol style="list-style-type: none"> <li>1. Deep crack developed on the walls of temple wall and a chunk of its ornate exterior hung precariously.</li> <li>2. A portion of the temple suffered significant damages.</li> <li>3. The crown of the temple had developed crack and the flag on top of the shrine was blown away under the impact of the strike</li> </ol>  |
| <b>Basilica of Bom</b>  | Goa, India, 2015   | <ol style="list-style-type: none"> <li>1. Lightning struck the structure and damaged a pillar and tiles on the roof.</li> <li>2. Lightning struck a pillar, which broke and felled a shower of stones and associated structure.</li> </ol>   |
| <b>Se Cathedral</b>   | Goa, India, 2014   | <ol style="list-style-type: none"> <li>1. Lightning destroyed one of the gables, while also damaging roof tiles at several places.</li> <li>2. The false ceiling of one of the halls near the priests' residence had been partly damaged.</li> </ol>   |
| <b>Mihinthalya</b>  | Anurudhapura, Sri Lanka, 2010                                | <ol style="list-style-type: none"> <li>1. Lightning struck the Basel terrace (Pesawa) of the Chaitya of the Mihintale Raja Maha Viharaya.</li> </ol>   |
| <b>Lord Buddha Statue</b>   | Avukana, Sri Lanka, 2017                                     | <ol style="list-style-type: none"> <li>1. Lightning struck on the metal enclosure (roof) used for overall protection of the statue.</li> </ol>   |

### III. CASE STUDIES OF HERITAGE MONUMENTS IN INDIA AND SRI LANKA FOR ANALYSIS OF LIGHTNING-HUMAN INTERACTION

Five heritage monuments which are in addition also important places of worship have been selected to analyze and ascertain the effects of human safety due to lightning. In Sri Lanka, three giant stupas [25] namely Jethawanaramaya, Abayagiriyaya and Ruwanwelisaya have been taken up for human- lightning interaction studies [26, 27]. The three stupas are the 3<sup>rd</sup>, 5<sup>th</sup> and 7<sup>th</sup> tallest ancient brick structures respectively and recently some of their heights have been lowered during renovation activities. LPS have been installed

and the devotees utilize the open space on the floor for congregating and worshipping. Considering spiritual and religious practices, wearing shoes, hats etc is prohibited in these places consequently exposing the human body to be in direct contact with the ground and more specifically the wet floor during the rainy season which is usually accompanied by lightning strikes. The details the monuments are indicated in Fig. 8, Fig. 9 and Fig. 10 and Table II.



**FIGURE 8.** Snapshot of Jethawanaramaya Stupa in Anuradhapura



**FIGURE 9.** Photograph of Abayagiriya Vihara



**FIGURE 10.** Snapshot of Ruwanweliseya

**TABLE II**  
DETAILS OF STUPAS IN SRI LANKA FOR LIGHTNING STUDIES

| Monument                                   | Description  | Location            | Dimensions   |
|--|--|---------------------|--|
| Jethawanaramaya, King Mahasen (273-301 AD) | World 3 <sup>rd</sup> tallest ancient brick structure, (original height - 122 meters)  | 80.4015E<br>8.3515N | Height -70.7 m<br>Radius-53.05m<br>Effective floor area -23,550 m <sup>2</sup>     |
| Abayagiriya-King Valagambahu, (89-77 BC)   | World 5 <sup>th</sup> tallest ancient brick structure (original height - 106.7 meters) | 80.3931E<br>8.3709N | Height - 74.7m;<br>Radius - 50.9 m;<br>Effective floor area -29,800 m <sup>2</sup> |
| Ruwanweliseya-King Dutugemunu (140 BC)     | World 7 <sup>th</sup> tallest ancient brick structure (original height - 92 meters)    | 80.3942E<br>8.3500N | Height 92.4 m;<br>Radius 41.9 m;<br>Effective floor area - 15,800 m <sup>2</sup>   |

From the Indian context, two giant medieval Chola temple monuments namely Brihadeesvara (Big temple or Peruvudayar Koil) and Gangaikonda Cholapuram [28] have

been chosen for detailed analysis since it is evinced from the discussions in Section II that these structures have experienced repeated lightning strikes and considerable damages have been reported during the past decade [29]. Nonetheless, the uniqueness of the Brihadesvara temple include features such as granite stone construction, pyramid structure of the tower (main gopuram called ‘Sri Vimana’), single granite stone spire (called the ‘kalash’ or ‘stupi’) weighing eighty tons, non-casting of the shadow of the Sri Vimana’s spire during the entire day, a single stone construction of the ‘sacred bull’ (called ‘nandhi’) etc. People worship both in the sanctum sanctorum and the open area of the precincts of the temple. Details of the location and features of the temples are summarized in Table III and depicted in Fig. 11 and Fig. 12.

**TABLE III**  
DETAILS OF TEMPLES IN INDIA FOR LIGHTNING ANALYSIS

| Monument  | Description  | Location                     | Dimensions   |
|---|--|------------------------------|--|
| Brihadeeswara (Big) Temple – Thanjavur, King Rajaraja Chola (1003 AD-1010 AD) | 10 <sup>th</sup> century UNESCO heritage site<br>66 m tall Main Tower (called ‘Sri Vimana’)    | 10°46’58” N<br>79°07’54” E   | Height of Sri Vimana - 66m;<br>Effective floor area of temple complex- 28,800 m <sup>2</sup>   |
| Gangaikonda Cholapuram-Jayankondam, King Rajendra Chola I (1025 AD- 1035 AD)  | 10 <sup>th</sup> century UNESCO heritage site<br>51.04 m tall Main Tower (called ‘Sri Vimana’) | 11°12’33.5” N<br>79°26’45” E | Height of Sri Vimana-51.04 m;<br>Effective floor area of temple complex- 20,123 m <sup>2</sup> |



**FIGURE 11.** Snapshot of Brihadishvara Temple in Thanjavur



**FIGURE 12.** Photograph of Gangaikonda Cholapuram in Jayankondam

#### IV. MECHANISMS OF LIGHTNING – HUMAN INTERACTION AND LIGHTNING HUMAN MODELING

When a human stands near a tall structure and specifically in the context of heritage monument, human-lightning interaction can be categorized into five major categories namely direct strikes, side flashes, touch potential, step voltage and ‘unsuccessful aborted upward leader’ called the ‘fifth mechanism’ [30]. Direct strikes and side flashes are likely to occur when the human stands in the vicinity of a tall structure. On the other hand, a high voltage may appear on the body of the human due to the influence of the touch potential and step voltage especially when a tall structure is protected by an LPS (usually the air terminal commonly referred to as “Franklin rod”) and when the human is nearby a lightning strike. In the fifth mechanism, another unique case of lightning strike wherein an aborted upward leader may start from the head of the human and may become unsuccessful due to striking of lightning to a nearby tall structure which in turn is most probably protected by LPS and grounded appropriately. Another unique mechanism that has been reported in recent studies, called the ‘sixth mechanism’ of lightning also includes ‘electromagnetic blasting’ due to lightning which relates to human injuries closer to the point of lightning strikes [31]. However, a few of the researchers of the lightning community have reported their disagreement to this aspect and attribute the event more to the lightning primary injury [32].

Hence, considering the aforesaid lightning mechanisms, the ultimate effect and cumulative impact of exposure of human to lightning might result into very severe injuries and sometimes leading to fatal consequences due to cardiac arrest [33]. Fig.13 shows the five lightning human interfering mechanisms namely 1. direct strike to the human from the CG flash; 2. side flash due to a direct strike to the monument; 3. touch voltage due to the current flow through the down conductor; 4. step voltage due to CG lightning flash to a nearby area and 5. unsuccessful upward abort leader due to CG flash connecting to a nearby point.

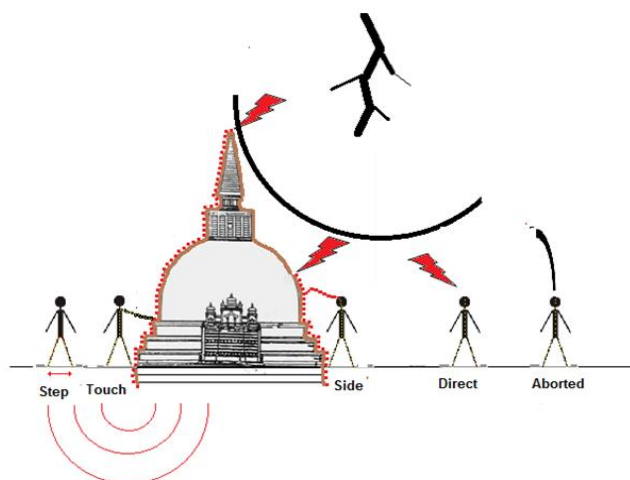


FIGURE 13. Lightning- human interaction mechanisms: Direct strike, side flash, touch potential, step voltage and aborted upward leader

##### A. DIRECT STRIKES

During cloud to ground (CG) flash, the stepped leader propagates towards the ground up to the striking point [34-39] and the striking distance ( $R_s$ ) [40, 41] is related to the lightning current which can be represented as

$$R_s = 10I^{0.65} \quad (1)$$

The current ‘ $I$ ’ is determined by the accumulated charge ‘ $Q$ ’ in the cloud, wherein  $Q = 0.06I$  is utilized during implementation. For a typical lightning current of 30 kA and with the most onerous case of lightning current of 200 kA, the striking distances are 91.2 m and 313 m respectively while the charges are computed to be 1.8 C and 12 C respectively. The lightning current probabilities are given by

$$P = \frac{1}{1 + \left(\frac{I}{31}\right)^{2.6}} \quad (2)$$

Accordingly the probabilities for 30 kA and 200 kA are respectively 52% and 0.8%. It can be ascertained on whether human standing on the floor is hit by direct lightning according to the rolling sphere method (RSM).

##### B. SIDE FLASHES

When a monument is under the influence of direct lightning and lightning current flows through the monument (probably along the wet surface), an instantaneous voltage can be built up along path of the current. If a human stays in the vicinity of such a current-path, side flashes can occur from the point of the lightning path to the human. The prospective vulnerable locations of such lightning strike points can be obtained based on the RSM based layout that indicate the profile of the LPZ. Hence, it is evident that by injecting a standard lightning current with a wave-shape 10/350  $\mu$ s to the striking point and allowing to flow through the surface, the potential distribution along the current path can be computed.

##### C. TOUCH POTENTIAL

When the LPS installed on the stupa is struck by lightning, current will flow through the down conductor and a corresponding voltage would be built up at the point of contact (usually at 1.5m from the ground). If the impedance of down conductor ( $Z_{DC}$ ) is represented by the series connection of down conductor resistance and inductance together with earth resistance ( $R_E$ ) representing the buried earth electrode, the voltage at the touch point can be computed as

$$V(t) = I(t)[Z_{DC} + R_E] \quad (3)$$

Where  $I(t)$  is an 10/350  $\mu$ s lightning current wave shape as stipulated in line with IEC 60060.

By considering the human RC model representation during lightning, the current through the human body can be calculated from

$$I_{BODY}(t) = \frac{V(t)}{Z_H + R_A + R_B + \frac{(R_L + Z_F)}{2} + R_{Con}} \quad (4)$$

Where  $R_{Con}$  is the contact resistance between the foot and the actual ground considered as zero potential which includes the resistance of the soil.

#### D. STEP VOLTAGE

When lightning current flows to the ground, the ground potential at the striking point rises instantaneously and decays along the surface of the flow. Hence, a voltage drop ( $\Delta V$ ) is induced across the legs of the human. Thus, the current flowing through the body can be written as

$$I_{BODY}(t) = \frac{V(t)}{2(Z_F + R_L)} \quad (5)$$

#### E. ABORTED UPWARD LEADER

During leader propagation, charge accumulates at different points on the human body, including the head and the built-up voltage on the head of the human is in turn taken to be ' $V(t)$ '. The current through the body can be computed as

$$I_{BODY}(t) = \frac{V(t)}{Z_{HD} + R_N + R_B + \frac{(R_L + Z_F)}{2} + R_{Con}} \quad (6)$$

In order to compute and analyze the extent of influence of lightning parameters [25-29], the human lumped circuit model representation as indicated in Fig. 14 coupled with an impulse generator circuit representing induced voltage is proposed for implementation and simulation of the various lightning human mechanisms so as to obtain and compare the current through the human body for each of the lightning instances.

The description of human model parameters taken up during the course of this research is summarized in Table IV. An impulse voltage generator which simulates the standard lightning impulse wave-shape has been modeled in OrCAD Cadence® software with typical values of the wave-shaping components namely  $R_1$ ,  $R_2$ ,  $C_1$  and  $C_2$  which are computed to be 200  $\Omega$ , 3200  $\Omega$ , 20000 pF and 1200 pF respectively.

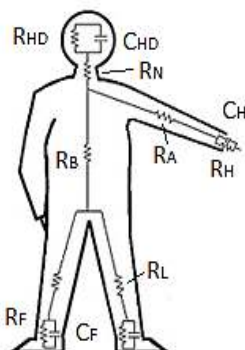


FIGURE 14. Lightning equivalent model representation of human

TABLE IV  
DESCRIPTION OF HUMAN RC EQUIVALENT MODEL REPRESENTATION DURING LIGHTNING STRIKE

| Description | Impedance | RC              |  |
|-------------|-----------|-----------------|--|
|             |           | Component       | RC Values  |
| Head        | $Z_{HD}$  | $R_{HD}/C_{HD}$ | $R_{HD}= 10 \text{ k}\Omega$ ,<br>$C_{HD}= 10 \text{ }\mu\text{F}$ |
| Neck        | $Z_N$     | $R_N$           | $R_N= 200\Omega$   |
| Body        | $Z_B$     | $R_B$           | $R_B= 300 \Omega$  |
| Arm         | $Z_A$     | $R_A$           | $R_H= 200 \Omega$  |
| Hand        | $Z_H$     | $R_H/C_H$       | $R_H= 10 \text{ k}\Omega$ ,<br>$C_H= 0.25\mu\text{F}$              |
| Leg         | $Z_L$     | $R_L$           | $R_L= 300 \Omega$  |
| Foot        | $Z_F$     | $R_F/C_F$       | $R_F= 10 \text{ k}\Omega$ ,<br>$C_F= 0.25 \mu\text{F}$             |

#### V. IMPLEMENTATION OF FINITE ELEMENT ANALYSIS AND HUMAN MODELING FOR LIGHTNING STRIKE ASSESSMENT STUDIES

As a first step, 3-dimensional computer aided design (3-D CAD) layout drawings have been generated in AutoCAD® for the five selected monuments (three stupas from Sri Lanka and two temples from India) with their appropriate dimensions. The layout description also includes a sketch of the LPS which in turn comprises the air terminations, down conductor and grounding systems which are appropriately marked at the respective places of the monuments. In order to investigate possible lightning-human interaction (in this case, the prospective devotees), RSM based EGM [42- 44] has been implemented in line with stipulations laid out by IEC 62305 in order to identify the possible vulnerable lightning striking points on the monument including the space (floor) related to the location wherein the devotees usually congregate to offer prayers. In this research, a typical lightning current of 30 kA as well as the most onerous case of 200 kA lightning current have been considered in order to assess the entire lightning current spectrum related to human interaction studies.

Juxtaposing, a finite element method (FEM) based approach has been utilized to analyze and investigate the risk of lightning strike on human devotees by considering the effect of the propagating downward leader, in addition to ascertaining the role of the material properties of the selected object (monument). As a part of FEM based studies, 3-D model representation of the heritage monument have been conceived, generated and simulated in COMSOL Multiphysics® software. Since several research studies have indicated that lightning usually initiates from the cloud at about 2000 m from the ground, the model representation for simulation has been implemented based on an overall cylindrical configuration having a height of 2000 m with a radius of 1000 m. The flat surfaces of the cylinder have been assumed to be the cloud and the ground so as to assign



Dirichlet boundary condition (fixed potentials) to these surfaces. On the other hand the curved cylindrical surface has been assigned as the Neumann boundary condition. In order to ensure meaningful simulation of the proposed structures, the monument is located (stupa is typically about 100 m tall while the temple towers called ‘gopurams’ are relatively less taller) at the center of the cylinder towards the ground (flat surface), so as to ensure symmetry of the geometry in addition to obtaining axisymmetric electric field profile. The downward leader has been placed from the cloud propagating towards the ground in steps of 50 m with uniformly distributed charges (1.8 C and 12 C respectively for lightning currents of 30 kA and 200 kA) placed on the leader. Since the typical thickness of the lightning channel is of the order of few centimeters while the size of the leader propagation of selected model has been assumed to be in the range of 1000 m, it has been observed during the simulation studies that this aspect presented considerable challenges in introducing precise meshing (solution of partial differential equations of the finite elements) towards obtain accuracy of the order of centimeters. Hence, fine meshing has been implemented only to specific locations of importance (leader tip and possible touching surfaces) related the monument whereas coarse meshing has been applied on the other places of lesser significance.

It is pertinent to note that the five lightning interaction methods deliberated thus far are analyzed either as pre-lightning scenario (electrostatic model) or as post-lightning (current model). Accordingly, direct strike and aborted upward leader cases have been analyzed using the electrostatic model while the other three methods have been examined using the current model. Equations for the electrostatics and current model are indicated in (7) and (8).

$$\nabla \cdot D = 0 \quad (7)$$

$$\nabla \cdot J = \nabla \cdot \left( -\sigma \nabla V - \frac{\partial(\epsilon_0 \epsilon_r \nabla V)}{\partial t} \right) \quad (8)$$

Where  $D$  is electric flux density;  $J$  is current density;  $V$  is electric potential. Table V shows permittivity and electrical conductivity of materials used in the models.

TABLE V  
DETAILS OF MATERIAL PROPERTIES OF HERITAGE MONUMENTS

| Location             | Material                | Relative Permittivity | Conductivity (S/m) (dry, wet) |
|----------------------|-------------------------|-----------------------|-------------------------------|
| Stupa Structure      | Brick, Stupa            | 4.2                   | 0.001, 0.01                   |
|                      | Soil                    | 9                     | 0.001, 0.1                    |
|                      | Crushed rock foundation | 6                     | 0.0001                        |
| Temple               | Granite gopuram         | 6                     | 0.0001, 0.001                 |
|                      | Soil                    | 12                    | 0.003, 0.04                   |
|                      | Crushed rock foundation | 6                     | 0.0001                        |
| LPS Surrounding Area | Copper Rod              | 1                     | $5.8 \times 10^7$             |
|                      | Air                     | 1                     | $8 \times 10^{-15}$           |

Each monument has been tested with each interaction method. The procedure used for the various interaction methods is summarized in Table VI.

TABLE VI  
SUMMARY OF PROCEDURE ADAPTED FOR THE ANALYSIS

| Interaction Type              | Locations and Dimensions   | Method   |
|-------------------------------|--|--|
| Direct strike (30 kA & 200kA) | The pilgrims are possibly at the furthestmost point from the monument (minimum shielding)  | <ul style="list-style-type: none"> <li>Implementation of RSM for checking the possibility of direct strike</li> </ul>  |
| Side flash (30 kA)            | Probability of vicinity of devotees being closer to the path of the lightning current in the monument  | <ul style="list-style-type: none"> <li>Deployment of FEM for ascertaining strikes at prospective points</li> <li>Simulation of current flow along the surface</li> </ul>   |
| Step voltage (30 kA)          | Installation of 3m long copper rods (at ground level and 0.3m below the ground level) placed 2m away from the monument in a 6m crushed rock foundation | <ul style="list-style-type: none"> <li>Implementation of FEM for obtaining the potential across the legs</li> <li>Human model circuit representation for obtaining the current</li> </ul>  |
| Touch voltage (30 kA)         | Installation of 3m long copper rods (at ground level and 0.3m below the ground level) placed 2m away from the monument in a 6m crushed rock foundation | <ul style="list-style-type: none"> <li>FEM for obtaining the touch voltage (at 1 m height of human)</li> <li>Human model circuit representation for obtaining the transferred energy generator</li> </ul>                            |
| Aborted upward leader (30 kA) | Pilgrims are possibly located at furthestmost point from the monument (minimum shielding)  | <ul style="list-style-type: none"> <li>FEM for obtaining the potential on the cranium of equivalent human model of devotee (at 1 m height of human)</li> <li>Human model circuit representation for obtaining the current</li> </ul> |

Fig. 15 and Fig. 16 depict the generic formulation of the 3-D representation of a stupa taken up for FEM based studies.

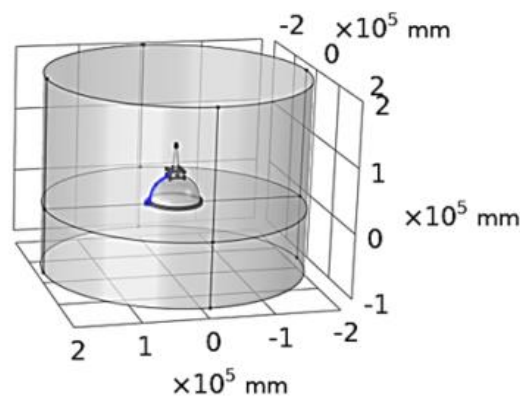
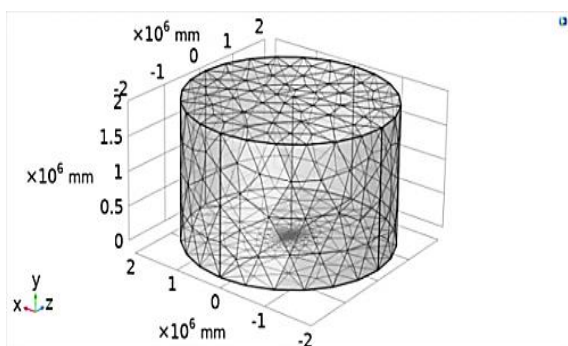


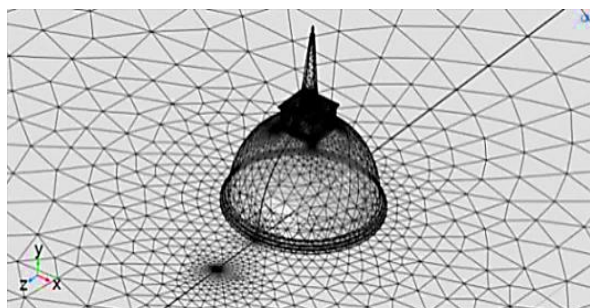
FIGURE 15. Typical COMSOL layout for monument for analysis of lightning-human interaction mechanisms



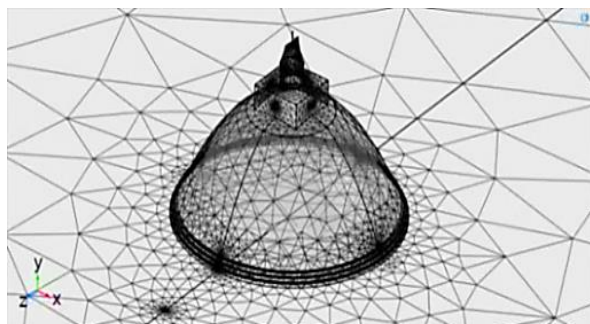


**FIGURE 16.** Typical overall FEM model of stupa (2 km height, 1 km radius)

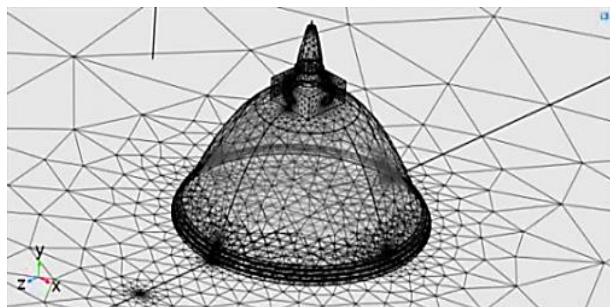
Fig. 17, Fig. 18, Fig. 19, Fig. 20 and Fig. 21 depict typical snapshots of the FEM meshing carried out based on the implementation of the boundary conditions for the stupas and temples considered as a part of the research study which has been discussed in this section..



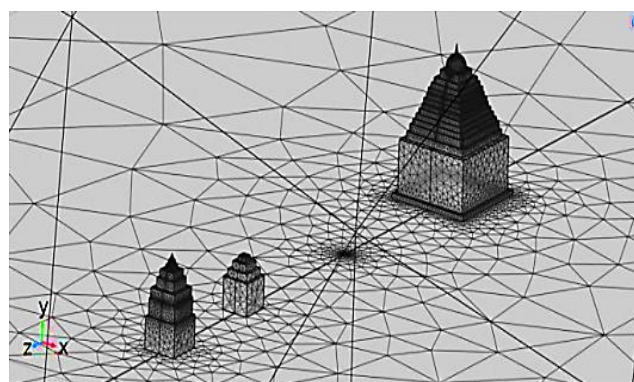
**FIGURE 17.** Typical meshing diagram for Ruwanweliseya



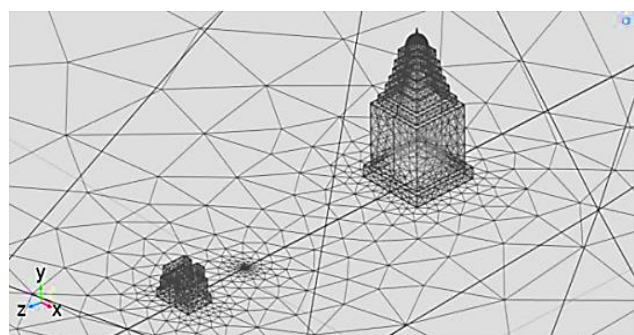
**FIGURE 18.** FEM meshing diagram for Jethwanaramaya



**FIGURE 19.** Typical meshing diagram for Abayagiriya



**FIGURE 20.** FEM meshing diagram for Big Temple

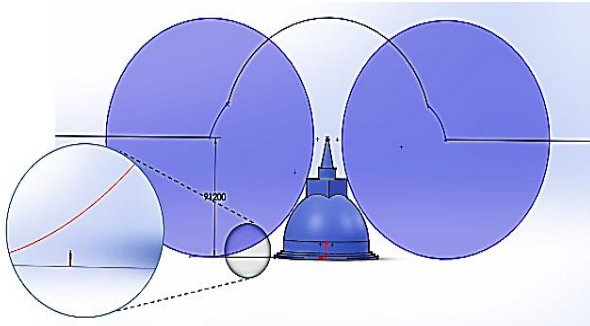


**FIGURE 21.** Meshing diagram for Gangikonda Cholapuram

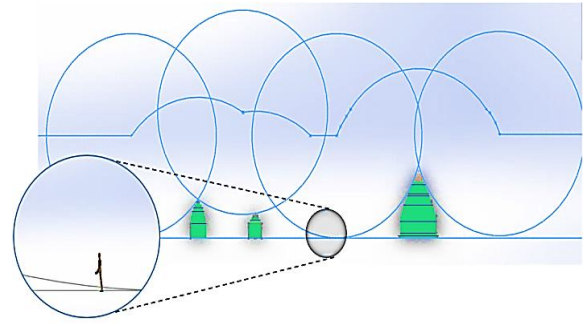
## VI. RESULTS AND DISCUSSIONS

### A. ANALYSIS OF IMPACT OF LIGHTNING ON HUMAN DUE TO DIRECT STRIKES

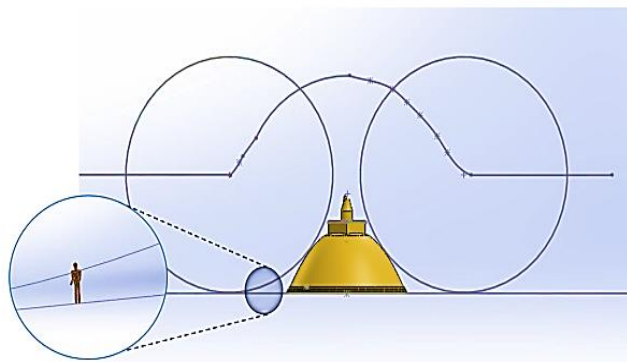
Fig. 22, Fig. 23, Fig. 24, Fig. 25 and Fig. 26 depict the loci of the leader tip and shielded area for a typical lightning current of 30 kA for the various stupas and temple monuments taken up for case studies of lightning protection zoning (LPZ). The onerous condition i.e. when the human is standing at the furthest point on floor has been analyzed to ascertain the risk of direct lightning strikes. It is evident from the detailed studies and analysis of the simulation that Ruwanweliseya stupa and Gangaikonda Cholapuram temple have no risk for devotees from direct strikes for 30 kA lightning current. However, it also evident that the boundary lines of the rolling sphere computed and generated for 30 kA passes through the body for the most critical location in Jethwanaramaya, Abayagiriya stupas as well as Brihadesvara temple. From the context of the area affected with respect to the overall floor of the monument, the risk of direct strikes to such places is very minimal. Thus it is obvious that the devotees are nearly shielded by the monument structure against direct lightning, though in the case of the big temple as depicted in Fig. 25, the devotees inside the nandhi mandapam may be vulnerable to strikes.



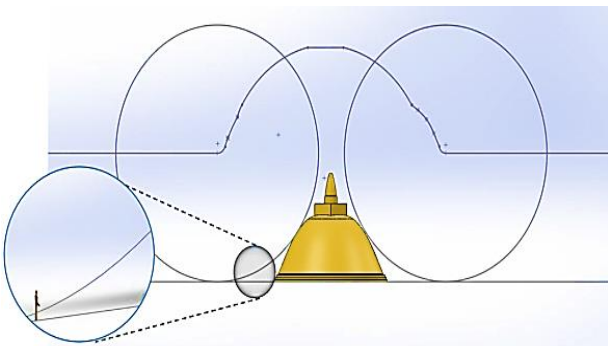
**FIGURE 22.** Simulation of loci of LPZ and vulnerable points of lightning strikes on human in Ruwanweliseya



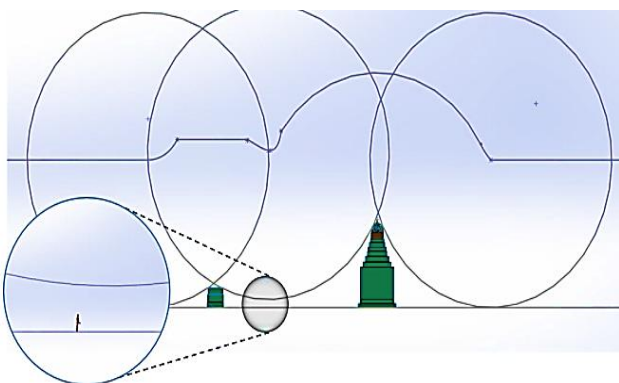
**FIGURE 26.** Loci of LPZ and vulnerable points of human in Big Temple



**FIGURE 23.** Loci of LPZ and vulnerable points of human in Jethawanaramaya



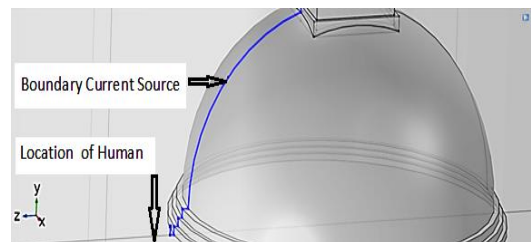
**FIGURE 24.** Loci of LPZ and vulnerable points of human in Abayagiriya



**FIGURE 25.** Loci of LPZ and vulnerable points of human in Gangaikonda Cholapuram

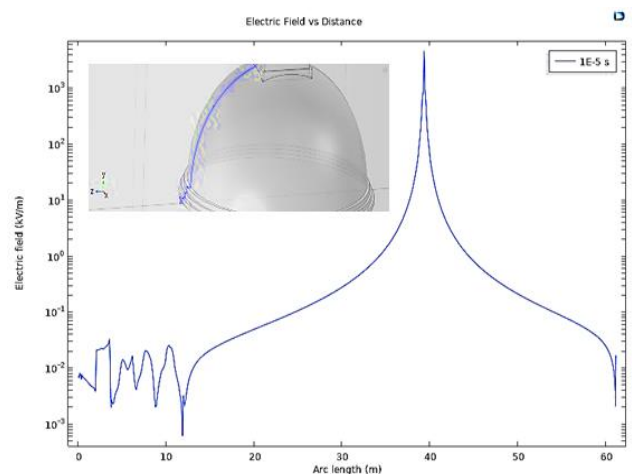
### ***B. ANALYSIS OF IMPACT OF LIGHTNING ON HUMAN DUE TO SIDE FLASH***

Detailed studies and analysis have been carried out on the stupas and temples including its precincts based on the layout of the COMSOL<sup>®</sup> simulation. The boundary current source is implemented and the simulated plots of the electric field distribution along the wet surface, floor and cranium of human have been obtained. Fig. 27 depicts the implementation of the boundary current source for lightning strikes on the dome of stupas and temple monuments.



**FIGURE 27.** Boundary current source and its location in stupas during simulation and analysis

Fig. 28 and Fig. 29 display the plot of electric field intensity of lightning from the position of the human to that of the point of impact of lightning at the dome of stupa and gopuram.



**FIGURE 28.** Electric field distribution during lightning strike on Ruwanweliseya



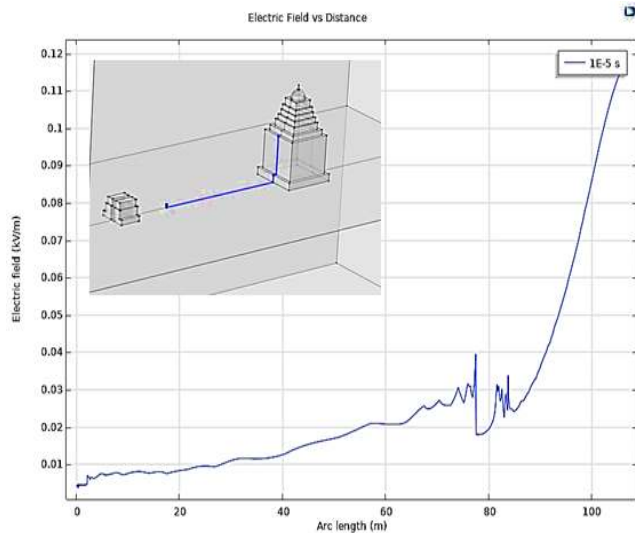


FIGURE 29. Electric field distribution during strike on Gangaikonda Cholapuram

### C. ANALYSIS AND COMPARISON OF IMPACT OF LIGHTNING ON HUMAN DUE TO STEP POTENTIAL

In order to estimate step voltages, electric potential distribution in the vicinity of the grounding rod during lightning discharge through the LPS has been computed by means of COMSOL simulation. The tested lightning current is 30 kA of a wave shape of 10/350  $\mu$ s. Since the depth of the installed grounding rod from the floor is also important for the step voltage, two cases i.e. rod on the ground surface and rod 0.3 m below the ground surface are also considered. In addition to that dry and wet conditions are simulated by adjusting the conductivity of soil and brick according to Table V. As a special case, a copper plate buried at a 3 m depth and connected to the grounding rod is also considered. Fig. 30 shows potential distribution along the ground level in the vicinity of the rod for few selected cases: (a) dry conditions with rod on ground level, (b) dry conditions with rod 0.3 m below ground level, (c) dry conditions with rod on ground level along with a plate and (d) wet conditions with rod on ground level. As expected, higher ground potential rise occurs near the earth rod for all the cases. Highest potential rise can be observed when the rod is at the ground level under dry conditions, i.e. case (a). Installation of the rod 0.3 m below the ground level reduces the maximum ground potential rise almost by 50%.

However, its effect is limited to the region near the rod. In case of a plate, significant reduction of the potential can be seen over a wide area surrounding the rod. The potential during wet condition is much lesser (<1% of case (a)) than under dry conditions. By considering these observations two worst cases: (a) and (b) have been selected for further analysis. Table VII summarizes the estimated step voltages of the pilgrim (devotee) when standing near the monument for the two cases. Two distances between legs i.e. standard 1 m distance and typical 0.3 m distance are considered.

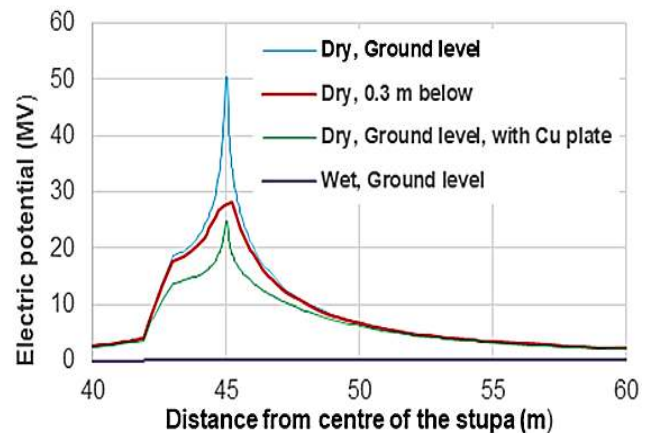


FIGURE 30. Potential distribution along the ground plane in the vicinity of the grounding rod: distance measured from the center of the stupa with earth rod located 45 m away from the center

It is clear from the results that the estimated steps voltages in general are high. However, the lightning interaction happens only within a period of several micro-seconds.. The estimated steps voltages for different monuments are in the similar range irrespectively of height or shape of the structure. It is also clear that the estimated step voltages for 0.3 m distance are lower than those at 1 m but the variation does not show any linear relationship. From the optimistic viewpoint, usually devotees usually walk on the floor (0.3 m gap) rather than running (1m gap). Interestingly, when the grounding rods are placed about 0.3 m below the ground the step voltages reduces. The results indicate the possibility of reducing the step voltage due to the placement of a ground rod at a certain distance below the ground surface.

TABLE VII  
STEP VOLTAGES FOR DIFFERENT MONUMENTS

| Monument              | At ground surface |              | 0.3 m below ground surface |              |
|-----------------------|-------------------|--------------|----------------------------|--------------|
|                       | At 1m (MV)        | At 0.3m (MV) | At 1m (MV)                 | At 0.3m (MV) |
| Ruwanweliseya         | 30                | 18           | 10                         | 4            |
| Abayagiriya           | 30                | 19           | 7.5                        | 2.5          |
| Jethawanaramaya       | 29                | 18           | 7.5                        | 2.5          |
| Gangikonda Cholapuram | 29                | 18           | 8                          | 3            |
| Big Temple            | 29                | 18           | 10                         | 4            |

### D. ANALYSIS AND COMPARISON OF IMPACT OF LIGHTNING ON HUMAN DUE TO TOUCH POTENTIAL

Table VIII shows the estimated touch voltages for different monuments considering different locations of the grounding rod. The touch potentials considered are at a height of 1 m along the down conductor connected to the ground. Similar to the step voltages, touch voltage values are also high and are reduced when the rod is placed 0.3 m below the ground



surface. However, it is obvious that the chances of touching the down conductor during lightning (usually rainy time) are highly unlikely. Thus, probability of having lightning interactions from touch voltage is at a minimal level.

TABLE VIII

TOUCH VOLTAGES FOR DIFFERENT MONUMENTS

| Monument              | At the ground surface (MV) | 0.3 m below the ground surface (MV) |
|-----------------------|----------------------------|-------------------------------------|
| Ruwanweliseya         | 51                         | 28                                  |
| Abayagiriya           | 47                         | 20                                  |
| Jethawanaramaya       | 46                         | 23                                  |
| Gangikonda Cholapuram | 47                         | 24                                  |
| Big Temple            | 47                         | 24                                  |

### E. ANALYSIS OF IMPACT OF LIGHTNING ON HUMAN DUE TO ABORTED UPWARD LEADER

In the case of aborted upward leader, the most onerous condition is during the instance of devotee standing at the furthestmost point from the monument. Table IX and Fig. 31 shows the estimated electric field on the head (cranium) of the human when the downward leader propagates from the cloud towards the human. Accordingly, 93 m is the striking distance for a typical 30 kA current. The estimation of the electric field beyond the striking point i.e. up to 45 m [30] is also included.

Based on the results summarized in Table 9, it is evident that the estimated electric field at the head of the human increases with the leader propagation. However, it is observed that there are no significant differences among such variations for all the simulated cases. Detailed analysis during the simulation clearly confirms that the risk for the aborted upward leader is nearly same irrespective of the type of monument (stupa or temple). It is interesting to note that the estimated electric field at the head of the human is greater than 300 kV/m. Once the leader is neutralized with any possible upward leader which originates from the LPS installed on the stupa, the accumulated charge on the head of the human due to its electric field will pass through the human body on the surface or internally depending on the extent to which wetting occurs.

TABLE IX

ELECTRIC FIELD DISTRIBUTION ON THE HEAD OF THE HUMAN DURING LEADER PROPAGATION

| Monument              | Distance to the leader tip from ground (meters) |     |     |      |
|-----------------------|---|-----|-----|------|
|                       | 300   | 200 | 93  | 45   |
| Electric field [kV/m] |   |     |     |      |
| Ruwanweliseya         | 138   | 189 | 391 | 816  |
| Abayagiriya           | 161   | 230 | 449 | 878  |
| Jethawanaramaya       | 141   | 207 | 425 | 1052 |

|                              |     |     |     |      |
|------------------------------|-----|-----|-----|------|
| Brihasvvara Temple           | 175 | 250 | 490 | 975  |
| Gangikonda Cholapuram Temple | 370 | 430 | 680 | 1175 |

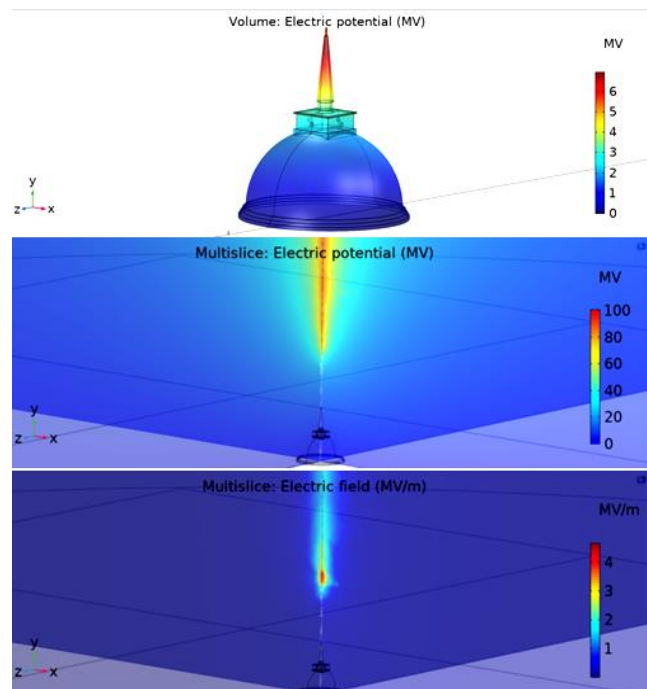


FIGURE 31. Enlarged snapshot view of electric potential and field distribution closer to the stupa for a 30 kA leader at 91.2 m from stupa top

### F. ANALYSIS OF LIGHTNING -HUMAN INTERACTION BASED ON HUMAN EQUIVALENT MODELING AND SIMULATION

Based on the details discussed in Section IV, an impulse generator to simulate lightning strokes has been implemented using OrCAD Cadence® in line with the stipulations laid out in IEC 62305 and as indicated in [13] with an impulse wave-shape of 1.2 / 50 μs. The lightning impulse voltage obtained with appropriate values pertaining to each type of lightning strike is in turn simulated in conjunction with the R-C equivalent human model representation as depicted in Fig. 14 and in [13] to ascertain the level of risk to human [45- 46] due to various factors such as role of earthing on the step and touch potential, distance of location from the point of strike due to side flash, influence of electric potential on the magnitude of currents through the body etc.

Simulation studies and analysis related to direct lightning strikes on the cranium due to dry lightning strikes, though impractical in real-time has been carried out to ascertain the effectiveness of the model in addition to ensuring calibration of the implemented simulation setup with the model that has been studied in [13]. Fig.32 depicts the implementation of the simulation related to direct lightning strike on human in the

vicinity of Ruwanweliseya, since the probability the lightning strike of the giant stupa may not be ruled out, though such direct lightning (dry) is invariably impractical.

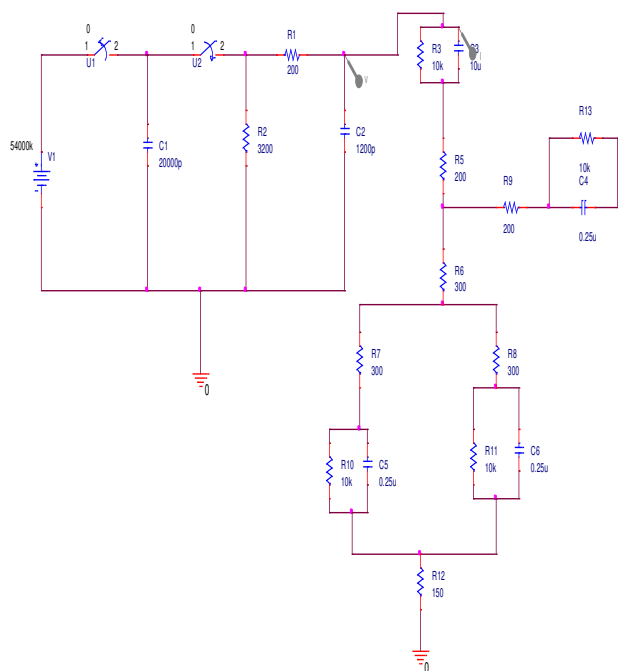


FIGURE 32. Simulation circuit for direct lightning strike on human in the vicinity of Ruwanweliseya

It is evident from Fig. 33 that the output current waveform reiterates the fact that direct strikes (dry) on the human may be detrimental and fatal, though impractical. Further, though a substantial 5 kA peak current is reached the time for the entire current to decay is of the order of 100  $\mu$ s.

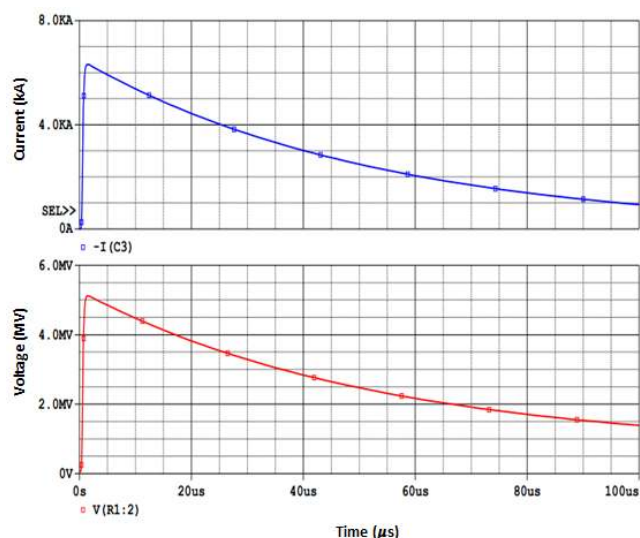


FIGURE 33. Body voltage and body current waveforms for direct lightning strike on human

In order to ascertain the development of potential across the feet of a human separated by 1 m distance (as stipulated

in standards) due to the lightning striking a nearby monument, equivalent R-C model representation studies have been carried out with varying distances of strikes at a distance of 1.5 m, 10 m and 20 m. Fig. 34 depicts the modeling and implementation of human lightning equivalent circuit due to varying distances of strike and its influence on increase of current that is detrimental to human. This aspect becomes significant since pilgrims visiting important monuments tend to congregate and in a few cases, rest nearby the shadow of such tall heritage structures thereby necessitating the analysis of step and touch potential.

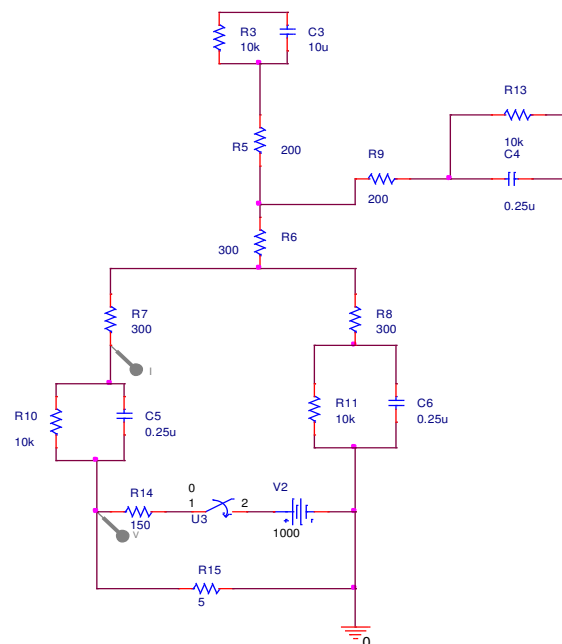


FIGURE 34. Simulation of human step potential due to direct strike to the LPS of the monuments (with 5  $\Omega$  earthing resistance)

Based on the lightning simulation studies conducted for varying distances of 20 m, 10 m and 1.5 m from the point of lightning strike on the monument and human, it is evident that greater the distance from the point of lightning strike on monument (10 m to 20 m) the lower is the potential across the feet. Hence, the current flowing through the human body is not substantially large to have a detrimental effect. For a distance of 10 m from the structure the magnitude of peak current for 1  $\Omega$  and 5  $\Omega$  earthing system is of the order of 11 mA and 52 mA for a very short duration of about 1.5  $\mu$ s. However, it is worth mentioning that for the distance within 1.5 m it is evident that substantial potential could develop across the feet leading to dangerous currents through human if the earth resistance cannot be maintained to a lower value. In this case it is observed that for earthing resistance system of 1  $\Omega$  and 5  $\Omega$ , peak current of the order of about 2.6 mA to 525 mA flows through the feet for the duration of 1.5  $\mu$ s. Since the estimated currents are small, possible damages to the human such as muscle contraction in the legs might occur instead of causing fatal accidents. Based on these

considerations, it is evident that appropriate and effective earthing system becomes a prerequisite for human safety in the vicinity of monuments. At the same time it is worth to mention that maintaining a very low earth resistance such as  $1\ \Omega$  is extremely difficult since the overall earth resistance is characterized by resistances of both the conductor and the soil. Detailed simulation studies carried out for various cases are depicted in Fig. 35, Fig. 36, Fig. 37 and Fig. 38 which indicate the current through human for earthing resistances of  $5\ \Omega$  and  $1\ \Omega$  for distances of 10m and 1.5m from the location of lightning flash.

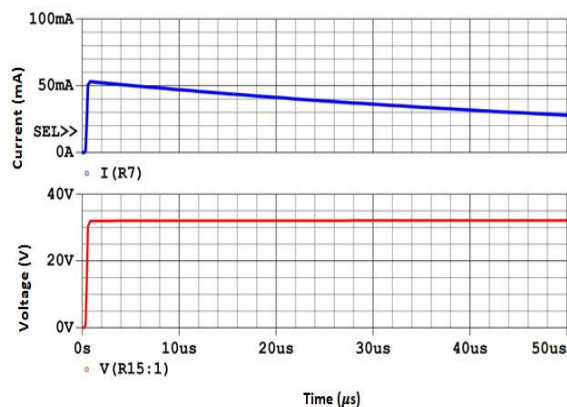


FIGURE 35. Step voltage and leg current waveforms of lightning flash at a distance of 10m from the monument with  $5\ \Omega$  earthing resistance

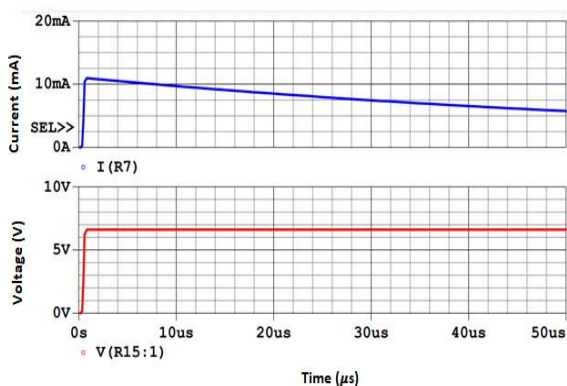


FIGURE 36. Step voltage and leg current waveforms of lightning flash at a distance of 10m from the monument with  $1\ \Omega$  earthing resistance

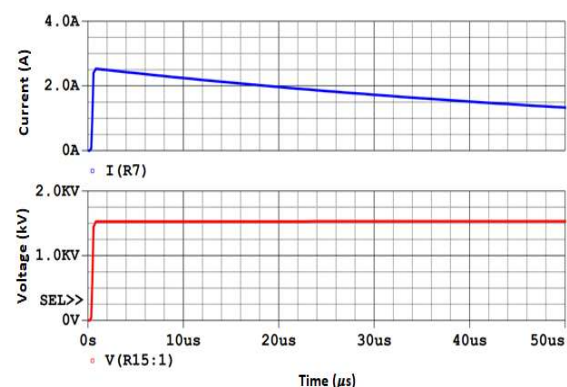


FIGURE 37. Step voltage and leg current waveforms of lightning flash at a distance of 1.5m from the monument with  $5\ \Omega$  earthing resistance

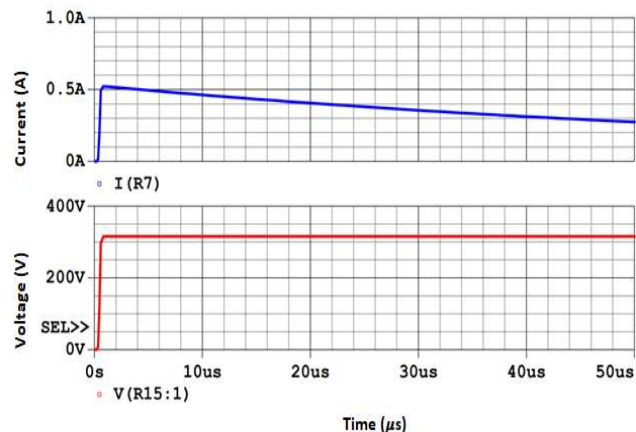


FIGURE 38. Step voltage and leg current waveforms of lightning flash at a distance of 1.5m from the monument with  $1\ \Omega$  earthing resistance

From the context of touch potential and its impact on human safety aspects and as evinced from the discussion in Section IV, pilgrims in the vicinity of the monuments struck by lightning are vulnerable to increase in the potential at the point of contact of the down conductors which forms a part of the LPS system installed in the monuments. Hence, studies and analysis have also been carried out to ascertain the touch potential of human in the vicinity of monuments considering that the down conductors are earthed for two varying values of earthing resistance namely  $5\ \Omega$  and  $1\ \Omega$ . Fig. 39 depicts the typical implementation of the simulation circuit for assessment of touch potential of human.

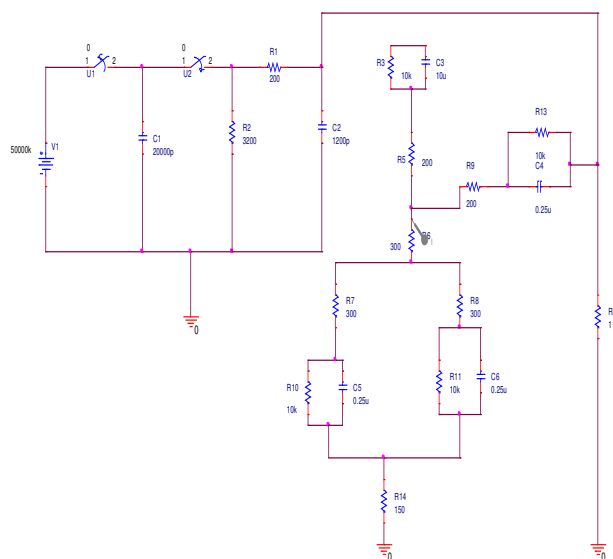


FIGURE 39. Simulation of human touch potential and current due to direct strike to the LPS of the monuments (with  $1\ \Omega$  earthing resistance)

It is evident from the studies that substantial increase in the flow of current through the outstretched arm of the human is likely notwithstanding the type of earthing, since the impedance offered by the arms is much lesser than that of the value of impedance of the cranium and the torso. Hence, a



large value of the peak current in the range of 280 A to 1.45 kA for 1  $\Omega$  and 5  $\Omega$  earthing system respectively is observed for the duration of 1.5  $\mu$ s. Fig. 40 and Fig. 41 display the waveforms of the current due to touch potential through the human for two varying values of earthing namely 5  $\Omega$  and 1  $\Omega$  which reiterate the observations during the simulation.

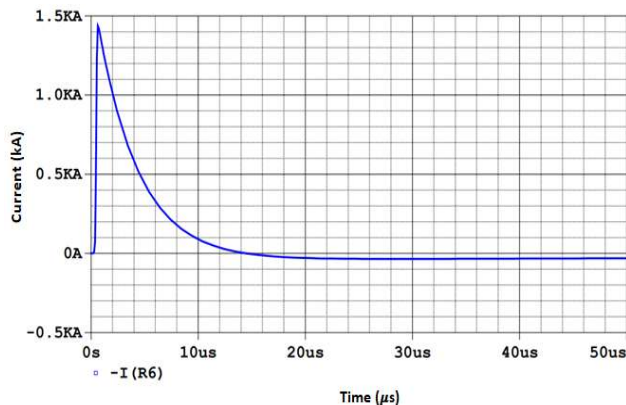


FIGURE 40. Current waveforms of human touch potential due to lightning on monument with earthing resistance of 5  $\Omega$

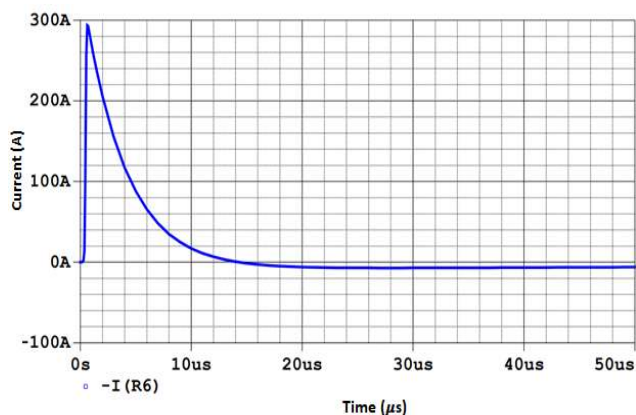


FIGURE 41. Current waveforms of human touch potential due to lightning on monument with earthing resistance of 1  $\Omega$

## VII. CONCLUSIONS

It is evident from the detailed analysis and from the context of lightning-human interactions that giant heritage monuments in India and Sri Lanka are prone to lightning strikes whereby necessitating thorough analysis to ensure appropriate protection of humans in the vicinity of vulnerable places. The monuments taken up for investigation as a part of this study have reported lightning damages and recorded lightning events for their respective LPS. The detailed analyses of the five case studies taken up in this research clearly indicate significant aspects of lightning-human interaction which are summarized:

1. It is evident from the study that humans are invariably protected in the premises of the investigated monuments from direct lightning flashes. This aspect could be ensured based on carefully devised shielding zone of protection

based on systematic implementing the RSM as stipulated in IEC 62305 whereby clearly demonstrating the efficacy of LPS in mitigating direct lightning strikes on human. The shielding effectiveness of the LPS devised during the course of this research also validated the analysis previously carried out by the authors of this research [30] whereby reiterating the findings of this study.

2. Lightning side-flashes may occur when humans are either closer to the down conductor of the LPS pertaining to the monument or to the lightning current path when a lightning directly strikes either the LPS or other non-protected areas respectively. However, considering the latter as a more onerous case, the study has found that the estimated electric field strength is not significant enough to initiate possible side flashes between the current path and the human. Values of electric field strength at a distance of about 10 m from the human is of the order of 200-300 V/m and hence found to be considerably low from the viewpoint of impact to human fatality.

3. It is evident that the risk of transferring lightning current through the human by instantaneously touching the lightning current path is considerably high. In this context, touching of the down conductor system of the LPS during lightning can be considered as the most stringent condition. The effect of lightning interactions to human by touch potential which has been modeled using FEM based current model in the post-lightning scenario clearly indicates the role played by effectiveness of grounding system of LPS and its impact on mitigating lightning strikes on human. Furthermore, the severity of impact of lightning on human due to touch potential is made evident as the values of peak current is observed to be in the range of 280 A to 1.45 kA and decays in about 12  $\mu$ s.

4. Risk of lightning-human interaction due to step voltage may also play a major role during lightning when a human stands in an open area near the LPS grounding system of the monument. The typical spacing between two legs of a human near the heritage monuments is comparatively lesser and more conductive than the prescribed spacing as stipulated in standards. Accordingly the estimated step voltages are typically lower. On the other hand, the step voltages are substantially lower in wetted floors and it can be further mitigated by burying earth rods at appropriate distance below the ground level. In this research, for the investigation carried out for the most onerous condition, (human standing closer to the earth rod buried to the top of the floor under dry condition) the possible energy transfer to the human can be significantly dangerous and fatal. This aspect is also observed during the simulation studies of human model wherein substantial current of the order of 525 mA to 2.6 A which decays at about 60  $\mu$ s, clearly indicated the criticality of the role played by earthing system in mitigating impact of lightning on human.

5. The aborted upward leader which is considered as the fifth mechanism of lightning-human interaction can also exhibit significant risk in some of the investigated cases

when the human stands at the furthestmost point from the monument with minimal shielding from the structure.

## ACKNOWLEDGMENT

The authors of this research work are extremely grateful to the Department of Science & Technology (DST), Government of India and Ministry of Science, Technology and Research (MSTR), Government of Sri Lanka for sanctioning and awarding the Bilateral India-Sri Lanka Research Project Grant No.: DST/INT/SL/P-14/2016/C&G which forms a part of this research study. The authors also thank the Archaeological Survey of India (ASI), New Delhi and Department of Archeology, Sri Lanka for according permission and approval to undertake lightning protection studies of heritage monuments and for their continued support in this research work.

## REFERENCES

- [1] Vernon Cooray, "An introduction to lightning," Springer, 2015.
- [2] R.D. Holle, "Annual rates of lightning fatalities by country," 20<sup>th</sup> International Lightning Detection Conference, Arizona USA, pp. 1-14, 2008.
- [3] I. Cardoso, O. Pinto Jr., I. R. C. A. Pinto, and R. L. Holle, "A new approach to estimate the annual number of global lightning fatalities", 14<sup>th</sup> Intl. Conf. Atmos. Electricity, Rio de Janeiro, Brazil, pp. 1-4, 2011.
- [4] "Accidental Deaths & Suicides in India," National Crime Records Bureau, Ministry of Home Affairs, Government of India, 2015
- [5] Omvir Singh, and Jagdeep Singh, "Lightning fatalities over India: 1979–2011," *Meteorological Applications*, 22, pp. 770-778, 2015
- [6] C. Gomes, M. Ahmed, F. Hussain and K.R. Abeysinghe, "Lightning accidents and awareness in South Asia: Experience in Sri Lanka and Bangladesh", 28<sup>th</sup> International Conference on Lightning Protection (ILCP), Kamasawa, Japan, Paper No. VIII-10, Sep 2006.
- [7] S. Sreedhar, and S. Venkatesh, "Lightning strokes and its effects on historical monuments, heritage properties and important landmarks a detailed perspective of traditional and scientific methods of lightning protection systems," *International Journal of Engineering and Technology*, Vol. 7, No. 2, pp. 784-794, 2018.
- [8] Thirumalini Selvaraj, Venkatesh Srinivasan, Simona Raneri, Manjula Fernando, Simon Jayasingh, "Response of Organic Lime Mortars to Thermal and Electrical Shocks Due to Lightning Strikes," *Sustainability*, Vol. 12, No.17, 7181, pp. 1-24, September 2020.
- [9] IEC 62305, "Protection against lightning: IEC 62305-1 to 4," 2020.
- [10] National Fire Protection Association, "NFPA 780: Standard for the Installation of Lightning Protection Systems," National Fire Protection Association, 2017.
- [11] C. Bouquegneau, "A critical view on the lightning protection international standard," *Journal of Electrostatics*, Volume 65, Issues 5–6, pp. 395-399 May 2007.
- [12] T. Horvath, "Problems with application of the protection angle method at three-dimensional structures," 29<sup>th</sup> Int. Conf. Light. Prot. ICLP, pp. 4-5, Uppsala, Sweden, June 2008.
- [13] Vernon Cooray, "The lightning flash," IET, 2014.
- [14] "Kalasam on Big Temple's Rajarajan Thiruvayil damaged in Lightning Strike." [Online]. Available: <https://www.thehindu.com/news/national/tamil-nadu/Kalasam-on-Big-Temples-IsquoRajarajan-Thiruvayil-damaged-in-lightning-strike/article15719847.ece>
- [15] "Lightning arrester averts major damage to Big Temple gopuram." [Online]. Available: <https://www.dnnext.in/News/TamilNadu/2018/06/06020148/1075055/Lightning-arrester-averts-major-damage-to-Big-Temple-vpf>
- [16] "Varanasi: Part of 500-year-old Ratneshwar Mahadev temple collapses due to lightning." [Online]. Available: <https://www.dnaindia.com/india/report-varanasi-part-of-500-year-old-ratneshwar-mahadev-temple-collapses-due-to-lightning-2188737>
- [17] "Lightning strikes heritage site in Khajuraho, damages temple." [Online]. Available: <https://www.hindustantimes.com/bhopal/lightning-strikes-heritage-site-in-khajuraho-damages-temple/story-cl4o61wUsltvSRcyL20KM.html>
- [18] "Temple bears lightning brunt – Chunks falls of 11<sup>th</sup> Century Structure." [Online]. Available: <https://www.telegraphindia.com/odisha/temple-bears-lightning-brunt/cid/1507044>
- [19] "Lightning strikes Se Cathedral." [Online]. Available: <https://www.heraldgoa.in/Goa/Lightning-strikes-Se-Cathedral/79621>
- [20] "Lightning strike damages Basilica roof, tiles, façade." [Online]. Available: <https://timesofindia.indiatimes.com/city/goa/Lightning-strike-damages-Basilica-roof-tiles-faade/articleshow/47560945.cms>
- [21] "Centuries-old temple damaged in lightning strike." [Online]. Available: <https://www.orissapost.com/centuries-old-temple-damaged-in-lightning-strike>
- [22] A. Bandara, C. Ratnayake, D. Ambepitiya, J.R.S. Kumara, M.A.R.M. Fernando, S. Venkatesh, and D.K. Jayaratne, "Lightning Risk Analyses on Protected Sri Lankan Heritage Stupas," 13<sup>th</sup> IEEE International Conference on Industrial and Information Systems (ICIIS2018), IIT Ropar, India 2018.
- [23] "Lightning strikes basel terrace of Mihintale Vihara Chaitya." [Online]. Available: <http://www.island.lk/2010/04/25/news4.html>
- [24] "Avukana temple: Increased lightning due to protective covering." [Online]. Available: <http://www.adaderana.lk/news/43919/avukana-temple-increased-lightning-due-to-protective-covering>
- [25] P. Munidasa Ranaweera, "Stupas of Sri Lanka – A Technological Study," S. Godage & Brothers Limited, 2018
- [26] U.K.R.M.H. Rajapaksha, J.R.S.S. Kumara, M.A.R.M. Fernando, S. Venkatesh, and D.K. Jayaratne, "Possible lightning hazards to humans near giant ancient stupa," 14<sup>th</sup> IEEE International Conference on Industrial and Information Systems (ICIIS2019), Kandy, Sri Lanka 2019.
- [27] A. Bandara, C. Ratnayake, D. Ambepitiya, J.R.S.S. Kumara, M.A.R.M. Fernando, K.A.S. Susantha, and D.K. Jayaratne, "Lightning analyses on ancient and new giant stupas," *Institution on Engineers*, Sri Lanka Kandurata Chapter, Annual Transactions, 2018.
- [28] S. R. Balasubrahmanyam, "Middle Chola Temples- Rajaraja I to Kulottunga I," Thomson Press (India) Limited, 1975.
- [29] S. Venkatesh, S. Thirumalini, Shashank Chandrasekaran, Srisailam Sreedhar, Kunal Kakria, M.A.R.M. Fernando and J.R.S.S. Kumara, "Three dimensional implementation of modified rolling sphere method for lightning protection of giant medieval Chola monuments in South India," 14<sup>th</sup> IEEE International Conference on Industrial and Information Systems (ICIIS2019), University of Peradeniya, Sri Lanka, 2019.
- [30] M. Becerra and V. Cooray, "On the Interaction of Lightning Upward Connecting Positive Leaders With Humans," *IEEE Trans. Electromagnetic Compatibility*, Vol. 51, No. 4, pp. 1001-1008, 2009.
- [31] R. Blumenthal and N. J. West, "Investigating the risk of lightning's pressure blast wave," *South African Journal of Science*, Vol.111, pp.1-5, 2015.
- [32] C. Gomes, "Lightning related human risks," *Environmental Risk Assessment and Remediation*, Vol. 1, Issue 3, pp. 1-15, 2017.
- [33] T. Christophides, S. Khan, M. Ahmad, H. Fayed, R. Bogle, "Cardiac Effects of Lightning Strikes," *Arrhythmia Electrophysiology Rev*, Vol. 6, No. 3, pp. 114–117, Aug 2017.
- [34] R. B. Anderson, and A. J. Eriksson, "Lightning parameters for engineering applications," *Electra*, No. 69, pp. 65–102, Mar. 1980.
- [35] K. Berger, R. B. Anderson, and H. Kroninger, "Parameters of lightning flashes," *Electra*, No. 41, pp. 23–37, Jul. 1975.
- [36] CIGRE WG 33.01, "Notes on Lightning Parameters for System Performance Estimations," *CIGRE Rep.* 86, 1986.

- [37] R. B. Anderson, and A. J. Eriksson, "A summary of lightning parameters for engineering applications," Proc. *CIGRE*, Paper No. 33-06, 1980.
- [38] CIGRE TF 33.01.03, "Lightning Exposure of Structures and Interception Efficiency of Air Terminals," *CIGRE Rep. 118*, 1997.
- [39] Rakov, Vladimir A., and Martin A. Uman, "Some properties of negative cloud-to-ground lightning flashes versus stroke order," *J. Geophys. Res. : Atmospheres*, Vol. 95, No. D5, pp. 5447-5453, 1990.
- [40] Cooray, Vernon, Vladimir Rakov, and Nelson Theethayi. "The lightning striking distance—Revisited." *J. Electrostat.*, Vol. 65, No. 5, pp. 296-306, 2007.
- [41] V. Cooray, V. Rakov, and N. Theethayi, "The lightning striking distance-Revisited," *J. Electrostat.*, Vol. 65, No. 5–6, SPEC. ISS., pp. 296–306, 2007.
- [42] M. Nassereddine and A. Hellany, "Designing a lightning protection system using the rolling sphere method," *2009 Int. Conf. Comput. Electr. Eng. ICCEE 2009*, Vol. 1, pp. 502–506, 2009.
- [43] Brusso, Barry. "The Electrogeometrical Model of the Rolling Sphere Method [History]." *IEEE Industry Applications Magazine* 22, no. 2, pp. 7-70, 2016.
- [44] Xie, Qizhang, Stephane Baron, Simon Fortin, and Farid P. Dawalibi, "Rolling sphere method using 3D Graphics approach," *IEEE Asia-Pacific Power and Energy Engg. Conf. APPEEC*, pp. 1-4, 2009.
- [45] V. Cooray, C. Cooray, and C.J. Andrews, "Lightning caused injuries in human," *Journal of Electrostatics*, Vol. 65, No. 5, pp. 388-394, May 2007.
- [46] Andrews, Christopher Joh, Mary Ann Cooper, Mat Darveniza, and David Mackerras, "Lightning injuries: electrical, medical, and legal aspects," CRC Press, 1991.

Power and Energy Society Chapter in 2010, the general chair of IEEE fourth International Conference on Industrial and Information Systems in 2009 and IEEE- Chair, Sri Lanka Central Region Subsection in 2009/2010. His research interests include condition monitoring, alternative insulation and outdoor insulation.



**SARATH KUMARA** (M'13, SM 17) was born in Ratnapura, Sri Lanka in 1979. He received the B.Sc. Eng. (Hons) degree in Electrical and Electronic Engineering in 2004 and M.Phil. degree in 2007, both from the University of Peradeniya (UOP) Sri Lanka. He obtained his Tec. Lic and PhD in 2009 and 2012 from Chalmers University of Technology, Gothenburg, Sweden. Currently he is a senior lecturer in the Department of Electrical and Electronic Engineering, University of Peradeniya. He is a senior member of IEEE and an associate member of IESL. His research interests include high voltage insulation materials, condition monitoring, gas discharge simulations, high voltage testing and power system modeling.



**S. THIRUMALINI** was born in Tamil Nadu, India in 1974. She received her Bachelor's Degree (B.E.) in Civil Engineering from Madras University and Master of Engineering in Environmental Engineering from Anna University in 2005 and 2007 respectively. She received her Ph.D. in 2015 from Vellore Institute of Technology, India in the domain of Heritage Lime mortar characterization and simulation. Her primary areas of research include scientific methods for restoration and repair of heritage structures, characterization of traditional building material using analytical techniques, carbonation and self-healing studies using organic lime mortars with emphasis on optimization of lime mortars products.



**VERNON COORAY** (F'16) received his Ph.D. degree in Electricity with special attention to electrical transients and electrical discharges from the Uppsala University, Sweden, in 1982. In 2000, he was promoted to the rank of full professor in electricity with special attention to transients and electrical discharges at the division for electricity of Uppsala University. From 2000 to 2002 he was the head of the Division for Electricity in the Department of Engineering Sciences. He has authored and co-authored more than 400 scientific papers and 22 book chapters on physics of lightning and electrical discharges, lightning interaction and electromagnetic compatibility. He is the editor of three books, *The Lightning Flash*, published by IEE (London) in 2003, *Lightning Protection* published by IEE (London) in 2009 and *Lightning Electromagnetics* published by IEE (London) in 2012. He is the Editor in chief of the *Journal of Lightning Research*. He was also a guest editor of two issues of *Atmospheric Research* and two issues of the *Journal Electrostatics*. He is also the vice president of the scientific committee of the International Conference on Lightning Protection (ICLP) and a member of the scientific committee of the Symposium on Lightning Protection (SIPDA).



**S. VENKATESH** (M'12) was born in Tamil Nadu, India in 1973. He received his Bachelor's Degree (B.E.) in Electrical and Electronics

Engineering from Annamalai University, India in 1994 and Master Degree in Technology-High Voltage Engineering from SASTRA University in 2004. He received his Ph.D. in 2013 from SASTRA University in High Voltage Engineering. He was with Alstom Limited, Systems Group-India, T & D Projects Division, as Assistant Manager- Engineering & Quality Assurance during 1999-2001. He then worked with the Department of Electrical and Electronics Engineering, School of Electrical and Electronics Engineering, SASTRA Deemed University, India as Senior Assistant Professor from 2006-2015. He is presently working with Vellore Institute of Technology, Vellore as an Associate Professor-School of Electrical Engineering. His specific areas of interest include condition monitoring of electrical insulation systems, EHV transmission, lightning protection systems for structures, computational intelligence. He is a member of IEEE, IEEE Dielectric Insulation Society, IEEE Industrial Applications and Smart Grid Community.



**MANJULA FERNANDO** (M'07-SM'10) was born in Colombo, Sri Lanka in 1966. He received the B.Sc. Eng. degree from the University of Peradeniya, Sri Lanka in 1993, the Tech. Lic., degree from the Royal Institute of Technology, Stockholm, Sweden in 1997 and the Ph.D. degree from the Chalmers University, Gothenburg, Sweden in 1999. At present, he is a senior Professor and head of Department of Electrical and Electronic Engineering. He is a chartered

Engineer, an International Professional engineer and fellow of Institution of Engineers Sri Lanka. He was the founder chair of IEEE Sri Lanka