



5th International Conference on Advances in Energy Research, ICAER 2015, 15-17 December 2015, Mumbai, India

Parameter Optimization of Three Phase Boost Inverter Using Genetic Algorithm for Linear Loads

Arunkumar.G^{a*}, Gnanambal.I^b, Naresh.S^a, Karthik.P.C^a, Jagadish Kumar Patra^a

^aVellore Institute of Technology, Vellore, India

^bGovt. College of Engineering, Affiliated to Anna University, Salem, India

Abstract

A high performance offline genetic algorithm based three phase boost inverter has been proposed in this work. The digital PI controller makes use of the offline genetic algorithm to improve the performance of the three phase boost inverter. The offline genetic algorithm is used to improve the dynamic response and decrease the content of total harmonic distortion in the three phase boost inverter. The genetic algorithm decreases the effect of the parameters such as rise time, settling time, peak overshoot and steady state error which influence the dynamic response of the system. The overall system efficiency and reliability is shown to be enhanced due to the offline genetic algorithm. The content of total harmonic distortion is also shown to be decreased due to the proposed offline genetic algorithm.

© 2016 The Authors. Published by Elsevier Ltd. This is an open access article under the CC BY-NC-ND license (<http://creativecommons.org/licenses/by-nc-nd/4.0/>).

Peer-review under responsibility of the organizing committee of ICAER 2015

Keywords: Three phase boost inverter; Genetic Algorithm; Linear loads.

1. Introduction

Variable-speed ac machine drives, uninterruptible power supplies, aerospace power systems, communication ring generators and various other important applications make use of switched mode DC – AC inverters [1-4]. Most applications making use of switched mode power inverters consists of loads that are critical and sensitive. Performance and high quality sinusoidal AC waveform has become a must in these applications.

* Corresponding author. Tel.: +919994247789; fax: 04162243092.
E-mail address: g.arunkumar@vit.ac.in

A high performance, genetic algorithm based three phase DC-AC boost inverter system has been proposed in this paper. Standard genetic algorithm has been used to tune the proportional constant and integral constant of the PI controller utilized in the three phase boost inverter system. So far, the three phase boost inverter system has been implemented successfully in fuel cell systems with battery back-up units. The fact that the three phase boost inverter converts the input DC voltage to boosted AC voltage without the aid of filter circuits makes it a very promising three phase inverter which could replace the popular conventional voltage source inverters. Moreover the genetic algorithm based PI controller will reduce the dynamic response of the system, thus providing a high quality sinusoidal output.

Standard genetic algorithm is a stochastic optimization method and it is based on the survival of the fittest motto of the Darwin's theory of evolution. It is a non-complicated, very effective optimization technique [5-6]. The standard GA does not require functional derivative information for searching a set of solutions to minimize the given objective function [7-8]. The above said properties of standard GA decreases the complexity in computation and search time. The properties also make standard GA fit for solving complex objective functions [9-13]. The genetic algorithm has been used to tune the controller constants of the PI controller used in the three phase boost inverter system.

Voltage mode control has been used to implement the proposed genetic algorithm based three phase boost inverter in closed loop. Small signal modelling has been used to make the system more stable under dynamic conditions. The novelty of the paper lies in the fact that, algorithm based optimization techniques have not been used till now in small signal modelled boost inverter systems.

2. Proposed System

The detailed circuit diagram of the GA based boost inverter system is shown in Fig. 1. It mainly consists of the power circuit block and Simulink + dSPACE 1104 block. Interfacing these two main blocks are the sensors and driver circuits. The power circuit block is a hardware set up consisting of the Input supply voltage supplied by the programmable DC power supply rated 80 V, 60 A. The system is made up of three boost converters. The usage of dSPACE1104 in the implementation of the control design for the GA based boost inverter is much effective and the time taken to implement the control design is also very less for real time applications. Real time control using dSPACE1104 is much easier. The control mechanism or control circuit is designed and implemented in MATLAB simulink. This control mechanism is accessed through dSPACE1104. This makes it very easy to control the GA based boost inverter system. The instantaneous behavior of the parameters can be monitored through the dSPACE control desk.

2.1 System KVL equations

The topology of the proposed three phase boost inverter achieves DC to AC conversion, by connecting between DC-DC boost converters and modulating the output voltages of the DC-DC converters sinusoidally. If three boost converters are connected and the output voltages of each boost converter are controlled to track a sinusoidal DC biased references which are 120 degree out of phase, the output line voltages will be a three-phase balanced sinusoidal set. To proof this claim, it is assumed that the tracking controllers are perfect and they produce DC biased sinusoidal output voltages irrespective of the output load currents of converters. Therefore, we can model each boost converter with an ideal AC voltage series with an ideal DC voltage sources.

The KVL equations of line voltages are as follows:

$$\begin{aligned}
 V_{ab} &= V_a + V_{dc} - (V_b + V_{dc}) = V_a - V_b \\
 V_{bc} &= V_b + V_{dc} - (V_c + V_{dc}) = V_b - V_c \\
 V_{ca} &= V_c + V_{dc} - (V_a + V_{dc}) = V_c - V_a
 \end{aligned}
 \tag{1}$$

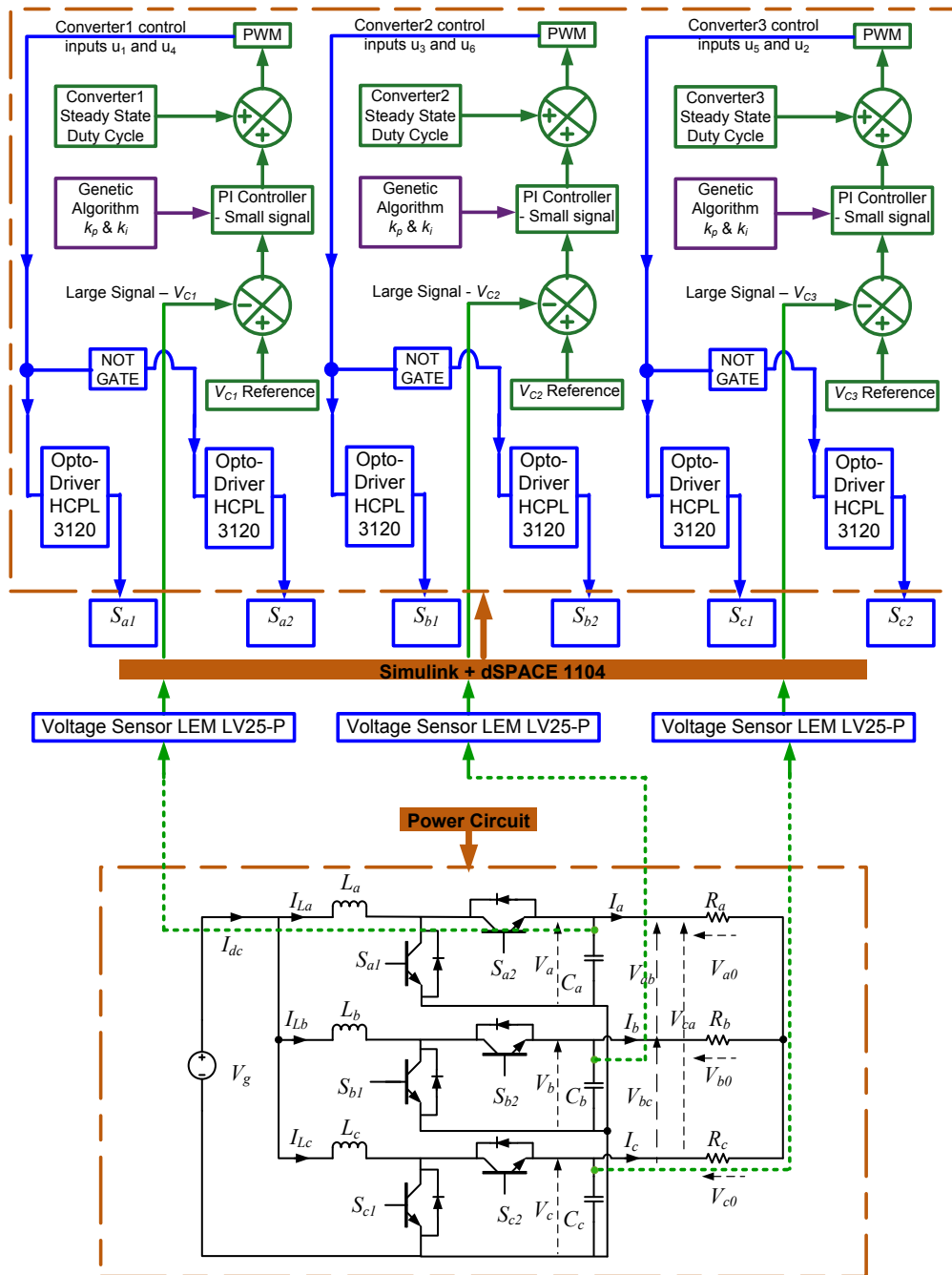

Fig. 1. Detailed block diagram of GA based single stage three phase boost inverter.

Where,

$$V_a = V_m \cos(\omega t)$$

$$\begin{aligned} V_b &= V_m \cos(\omega t - 120^\circ) \\ V_c &= V_m \cos(\omega t + 120^\circ) \end{aligned} \quad (2)$$

By substituting (2) in (1), three-phase line voltages are obtained as:

$$\begin{aligned} V_{ab} &= \sqrt{3}V_m \cos(\omega t + 30^\circ) \\ V_{bc} &= \sqrt{3}V_m \cos(\omega t - 90^\circ) \\ V_{ca} &= \sqrt{3}V_m \cos(\omega t + 150^\circ) \end{aligned} \quad (3)$$

It can be seen from the results that the line voltages in the load terminals of the proposed three-phase boost inverter is a symmetrical three-phase voltage without any DC voltage.

2.2 Parameters considered for optimization

When a disturbance affects the system, rise time, settling time, peak overshoot and steady state error are the parameters which will affect the output performance of the system. The effect of these parameters must be minimized. This system scenario has been formulated into an optimization problem with the given objective function and the fitness function so as to achieve a better dynamic response. The objective function is

$$F = (1 + t_r)(1 + t_s)(1 + P_o)(1 + E_{ss}) \quad (4)$$

$$\text{Fitness Function} = \frac{1}{F(\phi)} \quad (5)$$

Where,

- t_r – rise time
- t_s – settling time
- P_o – peak overshoot
- E_{ss} – steady state error.

K_p and K_i values:

The controller constants K_p and K_i to be utilized in the PI controller is taken from a particular range of values. The K_p value ranges from $K_{pmin}=0.000001$ to $K_{pmax}=0.0001$. The K_i value ranges from $K_{imin}=0.000001$ to $K_{imax}=0.0001$. The obtained controller values are $K_p=0.000053$ and $K_i=0.000009$. The output from the GA based PI controller is the small signal duty cycle of the system.

The large signal duty cycle from the summer can be monitored in real time through dSPACE control desk. The fluctuations in the duty cycle resulting from the abrupt line or load changes can be instantaneously seen in the dSPACE control desk.

3. Results

The hardware model of the three phase boost inverter system has been implemented in closed loop configuration as shown in Fig. 2. The three phase boost inverter set up was tested for a DC input voltage of 60 V to provide a three phase AC output voltage of 110 Vrms. These results have also been shown in the sections to come. The hardware result comparison has been shown in Table 1.

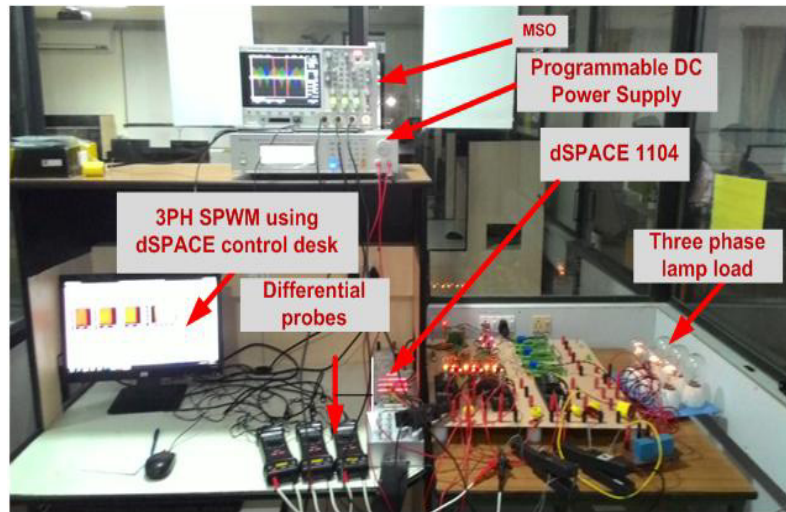

Fig. 2. Hardware setup of the proposed GA based three phase boost inverter

Table 1 Parameter specification for hardware.

Parameters	Traditional PI Controller Hardware values	Proposed GA based PI Controller Hardware values
Input dc voltage, V_{in}	60 V	60 V
Output ac voltage, V_o	110 V_{rms}	110 V_{rms}
Switching frequency	20000 Hz	20000 Hz
IGBT	CM100DU-12H	CM100DU-12H
Inductance, L	200 μ H	200 μ H
Capacitance, C	20 μ F	20 μ F
Load resistance, R	220 Ω	220 Ω
Real time interfacing	dSPACE1104	dSPACE1104
THD	3.59%	2.95%

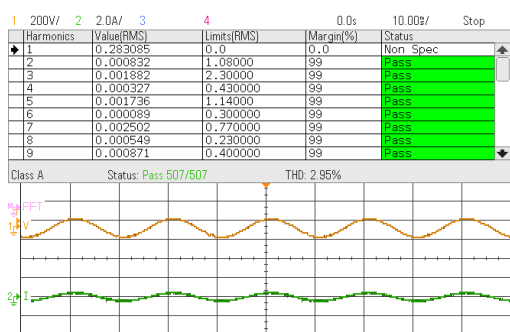

Fig. 3. Content of total harmonic distortion under GA

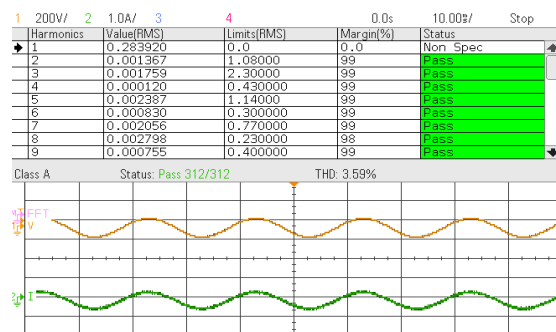

Fig. 4. Content of total harmonic distortion under traditional method

The THD value of the single stage three phase boost inverter system was determined and was found to be lower when the system was run using genetic algorithm. Results obtained from implementation of traditional and genetic algorithm in the system have been shown in Fig. 3 and Fig. 4 respectively. The lesser value of THD implies further harmonic reduction in the genetic algorithm based system when compared to the traditional system. The main

objective of the project is to achieve a low total harmonic distortion value (<5%) in accordance with IEEE 519 standards which is achieved. Because of its superiority steady state and line disturbance testing is being done on the genetic based system.

3.1 Steady state testing

For both the cases, the input was maintained at constant values of 60 V_{dc} and the load values were also maintained constant. It is observed from the results that the system reaches steady state within a cycle. The results for the system under steady state for an input of 60 V_{dc} and 110 V_{rms} output are illustrated in Fig.5 and Fig.6.

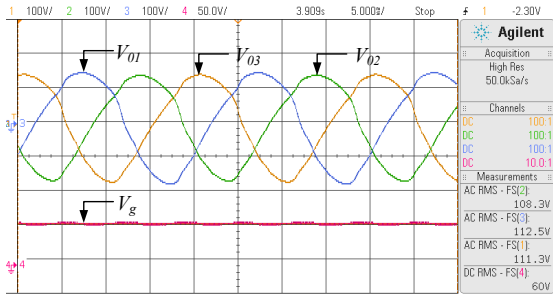

Fig. 5 Steady state phase voltages of three phase boost inverter

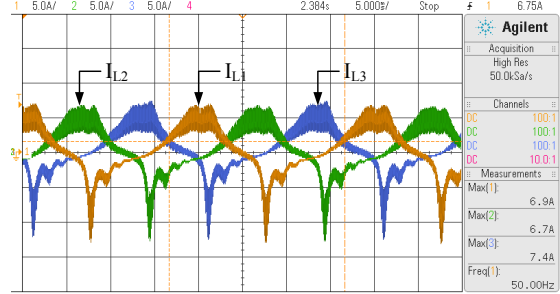

Fig. 6 Steady state inductor currents of three phase boost inverter

3.2 Testing under line disturbance conditions

The DC supply voltage is abruptly reduced or decreased from 60 V_{dc} to 58 V_{dc} . The hardware results for the system under line disturbance condition are illustrated in Fig. 7. The results prove that the output of the three phase AC voltages remains stable even during the line disturbance conditions. This particular test proves how robust, adaptable and stable the three phase boost inverter system is when implemented with GA.

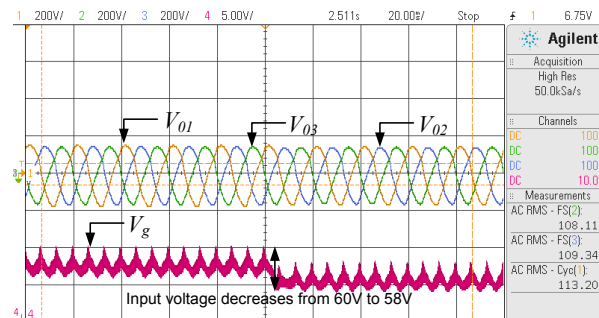

Fig. 7. System under line disturbance condition

4. Conclusion

A boost inverter which would convert the given DC voltage supply to three phase AC voltage has been implemented in closed loop in voltage control mode. The PI controller constants have been obtained both by the traditional as well as by using genetic algorithm and it is observed that when the model is implemented by genetic algorithm it gives a low THD value which suggests a better quality. Moreover it can be seen from the results that the output voltage remains stable even during the line disturbance condition proving that the system will remain stable, adaptive and robust and can withstand the disturbances in any system in which it is employed. The THD value was dutifully noted and was found to be 2.95 % by utilizing genetic algorithm which is an implication of the higher quality of the AC output voltage obtained from the inverter system

References

- [1] Pablo Sanchis, Alfredo Ursæa, Eugenio Gubía and Luis Marroyo, “Boost DC–AC Inverter: A New Control Strategy”, IEEE Transactions on Power Electronics, 2005, vol. 20, no. 2, pp.343-353.
- [2] Kapil Jha, Santanu Mishra and Avinash Joshi, “High-quality sine wave generation using a differential boost inverter at higher operating frequency”, IEEE Transactions on Industry Applications, 2015, vol. 51, no. 1, pp. 373–384.
- [3] Minsoo Jang and Vassilios G. Agelidis, “A minimum power-processing-stage fuel-cell energy system based on a boost-inverter with a bidirectional backup battery storage”, IEEE Transactions on Power Electronics, 2011, vol. 26, no. 5, pp. 1568–1577.
- [4] Pablo Sanchis, Alfredo Ursæa, Eugenio Gubía and Luis Marroyo, “Boost DC–AC inverter: A new control strategy”, IEEE Transactions on Power Electronics, 2005, vol. 20, no. 2, pp. 343-353.
- [5] Kinattingal Sundareswaran, Vadakke Devi, Selvakumar Sankar, Panugothu Srinivasa, Rao Nayak and Sankar Peddapati, “Feedback controller design for a boost converter through evolutionary algorithms”, IET Power electronics, 2014, vol. 7, no. 4, pp. 903-913.
- [6] K.Sundareswaran, K.V.S.Manoj Kumar Vadali, Shaik Khaled Nadeem and H.N.Shyam, “Robust controller identification for a boost type DC-DC converter using genetic algorithm”, 2008, IEEE Region 10 Colloquium and the Third ICIS, Kharagpur, INDIA Dec 8-10.
- [7] Kinattingal Sundareswaran, Vadakke Devi, Selvakumar Sankar, Panugothu Srinivasa, Rao Nayak and Sankar Peddapati, “Feedback controller design for a boost converter through evolutionary algorithms”, IET Power electronics, 2014, vol. 7, no. 4, pp. 903-913.
- [8] Kinattingal Sundareswaran and V.T. Sreedevi, “Boost converter controller design using queen-bee-assisted GA”, IEEE Transactions on Industrial Electronics, 2009, vol. 56, no. 3, pp. 778–783.
- [9] Mitchell, M. An introduction to genetic algorithms. Prentice-Hall of India Publications; 1996.
- [10] Y. Yu, and Y. Xinjie, “Cooperative coevolutionary genetic algorithm for digital IIR filter design”, IEEE Transactions on Industrial Electronics, 2007, vol. 54, no. 3, pp. 1311–1318.
- [11] A. Loredo-Flores, E.J. Gonzalez-Galvan, J.J. Cervantes-Sanchez and A. Martinez-Soto, “Optimization industrial, vision-based, intuitively generated robot point- allocating tasks using genetic algorithms”, IEEE Transactions on Systems, Man, and Cybernetics Part C: Applications and Reviews, 2008, vol. 38, no. 4, pp. 600–608.
- [12] W. Lenwari, M. Sumner, and P. Zanchetta, “The use of genetic algorithms for the design of resonant compensators for active filters”, IEEE Transactions on Industrial Electronics, 2009, vol. 56, no. 8, pp. 2852–2861
- [13] V.K. Koumoussis and C.P. Katsaras, “A saw-tooth genetic algorithm combining the effects of variable population size and reinitialization to enhance performance”, IEEE Transactions on Evolutionary Computation, 2006, vol. 10, no. 1, pp. 19–28.