

PAPER • OPEN ACCESS

Power Monitoring and Control System for Medium Voltage Smart Grid Using IoT

To cite this article: Challa Babu *et al* 2020 *IOP Conf. Ser.: Mater. Sci. Eng.* **906** 012007

View the [article online](#) for updates and enhancements.



ECS **240th ECS Meeting**
Oct 10-14, 2021, Orlando, Florida

**Register early and save
up to 20% on registration costs**

Early registration deadline Sep 13

REGISTER NOW

Power Monitoring and Control System for Medium Voltage Smart Grid Using IoT

Challa Babu¹, D. Dinesh Kumar^{1*}, Kumar K², K Jyotheeshwara Reddy³, R Sudha⁴

¹ Department of electrical and electronics engineering, Audisankara college of engineering and technology, Gudur, A.P, India

² Associate Professor, SV College of Engineering, Tirupathi, AP, India

³ Associate Professor, Sree Vidyanikethan Engineering College, Tirupathi, A.P., India

⁴ Division of Automation, Department of Production Systems, Höskolan Väst, Trollhättan, Sweden-46131

Abstract. This paper presents a power monitoring and control system for a medium voltage smart grid system. The smart grid interconnects the power sources between solar PV panel and 220V distribution network. This system consisting major components of inverters, measuring meters, solar charge controllers, relays, Arduino NANO and Raspberry Pi. The Current, power and energy readings are duly recorded. The Internet of Things (IoT) plays the vital role in the data communication between the sensors and electric power system. The voltage and current sensor data is used for the protection of power system network. In the traditional systems only the communication is uni-directional. The reliability of power supply is increased by used the bi directional network communication medium such as IoT. The tabulated results of voltage levels between 203.5V up to 212.8V shows the feasibility and effectiveness of proposed design. The proposed IoT model demonstrated the bidirectional communication from the sensors to the control unit and vice versa.

1. Introduction

Electric energy generated is transmitted and distributed through over head lines and underground cables at different voltage levels. In traditional system the power transactions were done via one way communication due to which generation of power at user side is not possible. This was overcome by the concepts of microgrid and smart grid. Smart grid uses the latest communicating technologies like smart metering systems and Internet of Things (IoT) which makes the tracking and controlling of power transactions more effective, flexible and transparent.

IoT is the most emerging technology where the devices communicate with each other through the cloud. IoT embedded devices will provide enhanced functionality without exposing the end user to the complexities of conventional computer based systems. These systems interface with the real world through sensors, and actuators. IoT devices are implemented in both hardware modules like Arduino, Raspberry Pi and software components. Smart metering technology with IoT makes the power transactions between the utility and consumers [1-6].

The smart grid includes hybrid power generation [7-10] integrating solar, wind and fuel cell energy resources. A Perturb and Observe (P&O) algorithm for Maximum Power Point Tracking (MPPT) is used for increasing power extraction efficiency [11-14]. In order to integrate the solar power generation with conventional grid fly back power processing converter is adopted [15]. Several monitoring techniques such as M2M low PAN wireless sensor network, integrating of renewable resources and traffic optimizing in smart grids are proposed in [16-18]. The main objective is to design the power monitoring and control system for a medium voltage smart grid using IoT.



2. Power Monitoring and Control system

The architecture of on grid solar power generation consisting of solar PV panels, MPPT solar charge controller, on grid inverter, storage batteries and three relays are shown in figure 1. The relay-1 shown in figure 1 is operated to determine the grid connected mode or islanded mode operation depending upon the supply from utility grid and charge condition of the batteries. If the batteries are fully charged the power generated by the solar panels is fed directly to the utility grid otherwise the power generated is used to charge the battery bank.

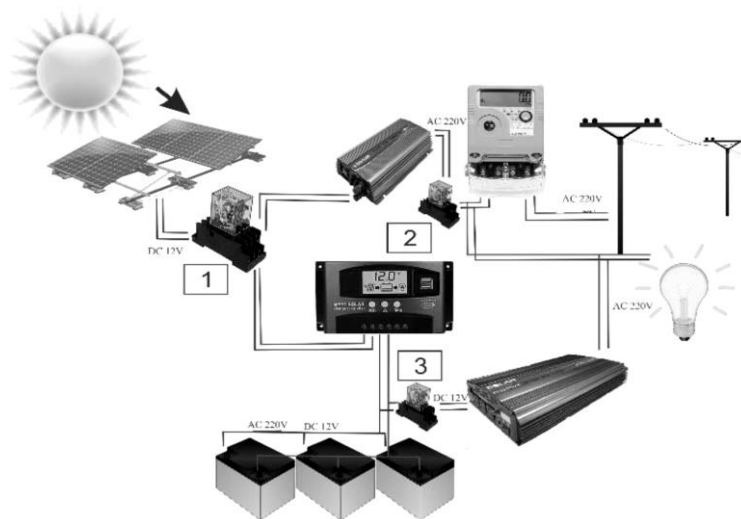

Figure 1: Architecture of on grid solar power generation.

The relay-2 is to connect and disconnect power supply from the solar PV panels while sending signal to the relay-1. If there is no power flow from the grid, the relay-2 disconnects the power supply from solar PV panels to the utility grid. In case of power flow from the grid was detected, the output power from the inverter is fed to grid.

The relay-3 connects or disconnects the battery from delivering the power to the load. This function is based on the incoming signal from the relay-2. If there is no incoming power from the utility grid relay-2 will send signal to relay-3 such that it connects battery bank to the load. In the same way if there is incoming power from the grid relay-3 disconnects the battery bank from the load.

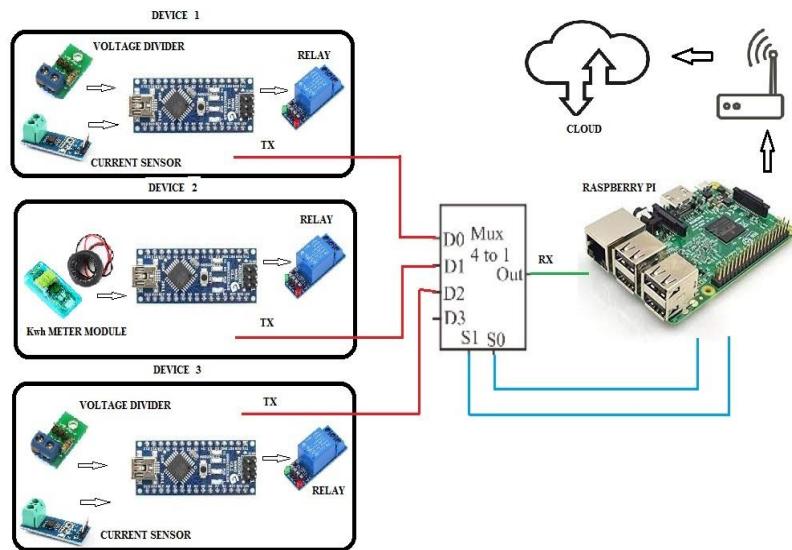

Figure 2: power monitoring and control scheme using Arduino nano and Raspberry Pi

The power monitoring and control scheme in medium voltage solar power generation is shown in figure 2. The Device 1 consisting of Arduino nano, voltage sensor, current sensor and a relay circuit which is used to regulate the power supply of the solar PV panels which feeds to the utility grid or to the battery bank depending upon the setting parameters.

The device-2 consisting of Arduino nano, Kwh meter module and a relay circuit which is used to connect and disconnect from the utility grid by sensing the incoming or outgoing current at the output side of the on grid inverter of solar PV panels. The device-3 consisting of Arduino nano, voltage sensor, current sensor and a relay circuit which is used to connect and disconnect the battery banks from the load. The central controlling unit which is Raspberry pi communicates with all the three devices. The central controlling unit receives data and sends data to the Arduino nano devices through the cloud which can be remotely accessible with smart mobile or computer.

3. Results and Observations

The monitoring system parameters voltage, current, power and energy are obtained in intervals of time via cloud which is shown in figure 3.



Figure 3: Display of parameters from the cloud.

A 16W lighting load is taken to monitor and control the proposed system and the testing results are tabulated in table 1.

Event No	Time (ms)	Voltage (V)	Current (A)	Power (w)	Energy (Kwh)
1	50	207.3	0.07	14.51	0.0522
2	100	207.8	0.07	14.546	0.0523
3	152	208.2	0.07	14.544	0.5240
4	200.5	209.1	0.07	14.637	0.0526
5	277	209.4	0.08	16.752	0.0603
6	310.2	209.4	0.07	14.658	0.0527
7	352	209.4	0.07	14.658	0.0527
8	400.5	209.9	0.07	14.693	0.0528

The voltage samples recorded at different instant of time are shown in figure 4. It was observed that the voltage values are in between 203.3V to 209.9V. The average value of all the events is 207.7 and standard deviation is 0.9 indicates that the voltage is monitored and controlled effectively.

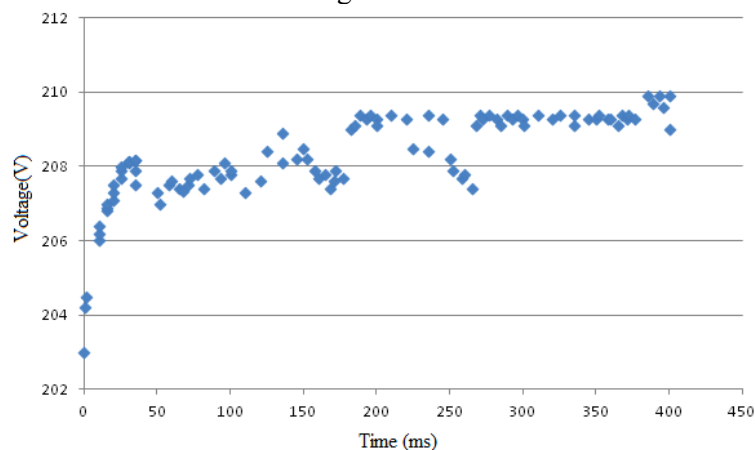

Figure 4: Voltage sample points at different instant of time (ms).

The current samples recorded at different instant of time are shown in figure 5. The average value for all the events is obtained as 0.07A. The load is disconnected at 400ms and therefore current becomes zero as shown. The energy consumed by the load in Kwh is shown in figure 6. The energy consumed was almost constant on an average at 0.05 of all the events and that becomes zero after disconnecting the load at 400ms

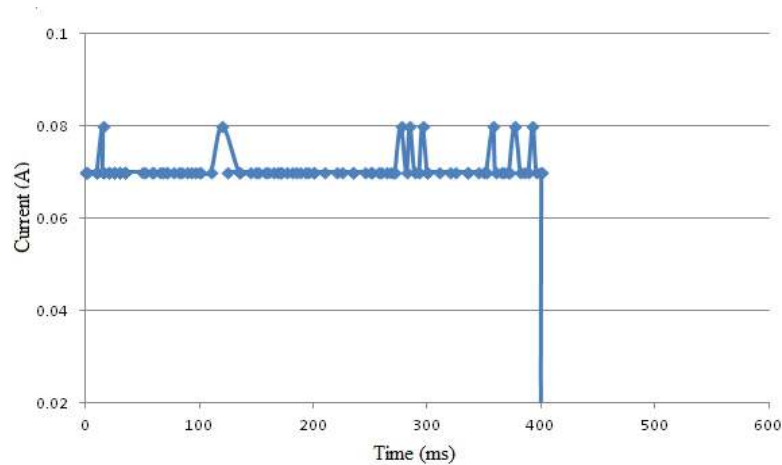

Figure 5: Current sample points at different instant of time (ms).

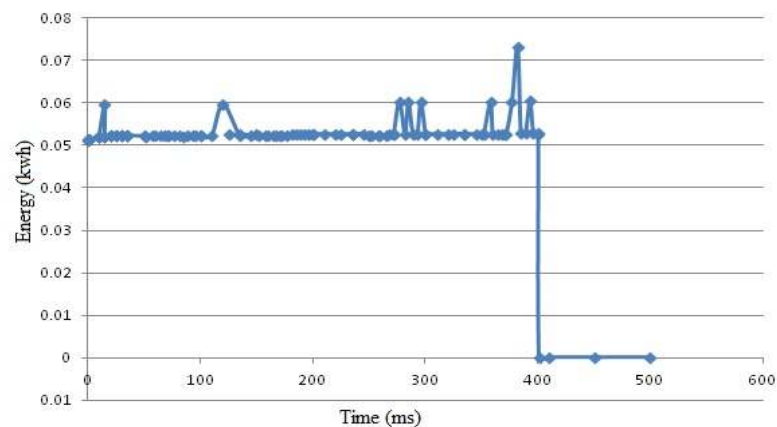

Figure 6: Energy consumed by load at different instant of time (ms).

4. Conclusion

The smart grid technology is the effective solution to perform the power transactions between the utility and the end users. In order to control distribution generating units of a microgrid, and monitor power transactions by different consumers effectively the Communication system play very important role. Therefore, A Power Monitoring and Control System for Medium Voltage Smart Grid Using IoT is developed. The voltage is controlled with a standard deviation of 0.9. The current values and energy consumed are constant at 0.07A and 0.05 respectively. The results obtained show the effectiveness of proposed scheme with and without load conditions.

5. References

- [1] Challa Babu, D. Dinesh Kumar, K.Jyotheeshwara Reddy, Kumar K., R. Sudha, 'IoT Enabled Interactive Advanced Metering Infrastructure Technology in Smart Grids', International Journal of Recent Technology and Engineering, ISSN: 2277-3878 (Online), Volume-8 Issue-5, January 2020. Page No. 3483-3488.
- [2] Raut, M.M., Sable, R.R. Toraskar, S.R., Internet of Things(IoT) Based Smart Grid, International Journal of Engineering Trends and Technology (IJETT), Vol. 34, No. 1, April 2016, ISSN 2231-5381, pp.15-20.

- [3] Camacho, E.F., Samad, T., Sanz, M.G., Hiskens, I., Control for Renewable Energy and Smart Grids, The Impact of Control Technology, 2011.
- [4] Natsheh, E.M., Albarbar, A., Yazdani, J., Modeling, and control for smart grid integration of solar/wind energy conversion system, 2011 2nd IEEE PES International Conference and Exhibition on Innovative Smart Grid Technologies, Manchester, UK, 5-7 Dec. 2011.
- [5] D. Dinesh Kumar, Challa Babu, K Jyotheeswara Reddy, Kumar K, N K Kumar, "An improved P&O MPPT control algorithm for increasing power extraction efficiency of solar PV module". In IOP Conference Series: Materials Science and Engineering 2019 Oct (Vol. 623, No. 1, p. 012020). IOP Publishing.
- [6] D. Dinesh Kumar, Challa Babu, P. Ponnambalam, "A Flyback Partial Power Processing Converter based Solar PV Systems Interfacing the Grid" IEEE conference, Innovations in Power and Advanced Computing (i-PACT-2019) 10.1109/i-PACT44901.2019.8960045.
- [7] Shrihariprasath, B., Rathinasabapathy, V., Design and Implementation of Solar PV Smart Grid System Using IoT and M2M Integrated 6LowPAN Wireless Sensor Network, International Conference on Advances in Information Technology and Networking, Feb. 2017.
- [8] Foley, A., Connolly, D., Leahya, P., Mathiesend, B.V., Lunde, H., Leahy, M., McKeogha, E., Electrical Energy Storage & Smart Grid Technologies to Integrate the next generation of Renewable Power Systems, SEEP2010, Conference Proceedings, June 29th-July 2d, 2010, Bari, Italy
- [9] Habault, G., Lefranc, M., Lemercier, F., Montavont, N., Chatzimisios, P., Papadopoulos, G.Z., Monitoring Traffic Optimization in Smart Grid, IEEE Transactions on Industrial Informatics, Jan. 2017, pp.1-9.
- [10] Babu Challa, and P. Ponnambalam. "The role of thermoelectric generators in the hybrid PV/T systems: A review." Energy Conversion and Management 151 (2017): 368-385.
- [11] Babu, Challa, and P. Ponnambalam. "The theoretical performance evaluation of hybrid PV-TEG system." Energy Conversion and Management 173 (2018): 450-460.
- [12] Kumar DD, Babu C, Reddy KJ, Kumar K, Kumar NK. An improved P&O MPPT control algorithm for increasing power extraction efficiency of solar PV module. In IOP Conference Series: Materials Science and Engineering 2019 Oct (Vol. 623, No. 1, p. 012020). IOP Publishing.
- [13] Babu, Challa, and Ponnambalam Pathipooranam. "PV Module Temperature Estimation by Using ANFIS." Soft Computing for Problem Solving. Springer, Singapore, 2020. 311-318.
- [14] Ponnambalam, P., Praveenkumar, M., Babu, C., & Raj, P. D. (2017). Analysis of Stacked Multicell Converter with Fuzzy Controller. In Proceedings of Sixth International Conference on Soft Computing for Problem Solving (pp. 318-330). Springer, Singapore.
- [15] Leela Madhav.k , Challa Babu, Dr.P.Ponnambalam, Ashutos Mahapatra., " Fuzzy Logic Controller for Nine Level Multi-Level Inverter with Reduced Number of Switches" IEEE conference i-PACT-2018, DOI: 10.1109/IPACT.2017.8244938.
- [16] S. Gupta, N. Sinha, R. Sudha and C. Babu, "Breast Cancer Detection Using Image Processing Techniques," 2019 Innovations in Power and Advanced Computing Technologies (i-PACT), Vellore, India, 2019, pp. 1-6, doi: 10.1109/i-PACT44901.2019.8960233.
- [17] Ponnambalam, P., K. Muralikumar, P. Vasundhara, S. Sreejith, and Babu Challa. "Fuzzy Controlled Switched Capacitor Boost Inverter." Energy Procedia 117 (2017): 909-916.

- [18] Anipireddy, P., and C. Babu. "Modeling and Simulation of Three Level Piezoelectric Transformer Converters." *Adv Robot Autom* 3.120 (2014): 2.